

## Calibration Test Equipment

### Digital Pressure Calibrator

### Wallybox 65-2000 II

WIKA Data Sheet CT 31.01

The **Wally Box II** is ideal for the maintenance, testing and certification of pressure transmitters and gauges. The unit is built into a robust case with an internal pressure pump making the Wally Box II suitable for self-sustained field and laboratory use. Unit can display simultaneous pressure and current voltage readings. Wally Box II is equipped with a 24 V sensor power supply.

#### GENERAL INFORMATION

**Wally Box 65-2000 II** portable calibration unit has improved the design and functionality of the Wallace and Tiernan unit 65-120. This design was developed with cooperation between WIKA and Wallace and Tiernan. The Wally Box II can be used in many diverse high precision testing applications.

The Wally Box II is small and mobile, but highly accurate .02% of the reading. Not only is the Wally Box II capable of precision pressure gauge testing, it can also be used for exact current and voltage measurements. Pressure readings and electrical measurements are displayed simultaneously.

The unit is supplied in a robust carrying case that is dust and water tight. This makes the Wally Box II suitable for difficult industrial field applications.

The built-in sensor is designed to allow for gauge and differential readings without additional setup or equipment. With external vacuum supply unit can also perform compound, vacuum and absolute pressure tests. Pressure output can be displayed in eight different pressure units at the touch of a button.

#### CONSTRUCTION AND FUNCTION

The digital pressure calibrator is equipped with a standard RS-232 interface and is powered by an integrated NiMH-battery or an external universal plug-in power supply for the line voltage of 100...240 V AC.

With the integrated precision pressure regulator for external air supply and the integrated hand pressure pump with a precision pressure controller for internal air supply, two different pressures can be provided. Both test pressures are working independently of each other. Based on these functions a variety of different application possibilities for the maintenance or calibration of pressure transducers are possible.

A flow diagram on the front panel informs the user about the connection of the single pneumatic components. The surface of the digital pressure gauge is covered completely by a front membrane keypad.

The accuracy of the pressure measuring system is 0.02 % of reading (incl. linearity-, hysteresis- and temperature error).



Wally Box 65-2000 II

#### ADVANTAGES

- high accuracy of 0.02% of reading  $\pm 3$  digits
- high accuracy for current and voltage measurements
- 24 V sensor supply
- line or battery powered
- battery status display
- simultaneous readout of pressure and electrical measurements
- RS232-interface
- integrated pressure supply with internal hand pressure pump and precision pressure controller
- precision pressure regulator for external pressure supply
- N.I.S.T. Traceable certificate

## PRESSURE MEASUREMENT

### Range:

-10...100 PSI (- 0.7...7 bar)

### Accuracy:

0.02% of reading  $\pm$  3 digits  
(incl. linearity-, hysteresis and temperature error)

### Temperature compensation:

compensated in the range of +50°F up to +105°F  
(error in specified tolerance by temperature changes less than 45°F/hour)

### Resolution:

10,000 digits (0.01 PSI)

### Pressure units:

mbar, bar, kPa, mmHg, IN.H<sub>2</sub>O (20°), IN.Hg, PSI  
and one programmable unit: default mH<sub>2</sub>O (20°)

### Display:

LCD display 2 x 16 character, 8 mm height,  
with backlight (switchable)

### Static pressure:

max. 100 PSI (7 bar) via connection "S"

### Pressure overload safety:

2 times

### Pressure overload warning:

Optical warning at 5% overload (blinking display)  
and acoustical warning at 10 % overload.

## ELECTRICAL MEASUREMENT

### Voltage range:

range / accuracy: 0... $\pm$  32 V DC  
0.04% FS  $\pm$  2 digits

### Resolution:

32,000 digits (0,001 V)

### Current range:

range / accuracy: 0... $\pm$  32 mA DC  
0.04% FS  $\pm$  2 digits

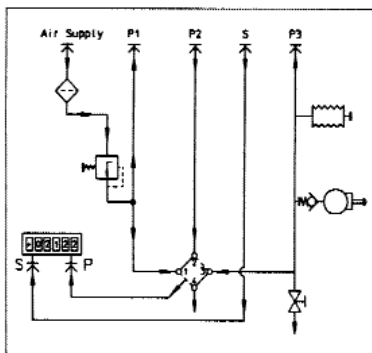

Pneumatic flow design of Wally Box 65-2000 II

Specifications and dimensions given in this leaflet represent the state of engineering at the time of printing.  
Modifications may take place and materials specified may be replaced by others without prior notice.



### Resolution:

32,000 digits (0.001 mA)

### Temperature error:

current- / voltage measurement  
max. 0.002%/K

### Electrical input impedance:

voltage input >10 MOhm  
current input < Ohm

### Sensor supply:

24 V DC  $\pm$ 10%, galv. isolated 500 V DC  
max. current 30 mA

### Operation temperature:

compensated range  $\pm$  50°F...+ 104°F  
storage temperature  $\pm$  14°F...+ 140°F

### Safety issue:

CE, MIL-4150H  
protection IP 67 (with closed case cover)

### Dimensions / weight:

L 13.5" x H 11.5" x W 6" / 12 lb.

### Pressure connections:

5 x 1/8"-NPT female thread

### Pressure supply:

ext. pressure supply max. 100 PSI  
(only clean dry air)

### Power supply:

100...240 V AC 50/60 Hz ( $\pm$ 10%)  
for line and battery supply

### Digital interface:

standard RS232 serial interface