

Keysight 87421A/87422A Power Supply

Technical Overview





Introduction

The Keysight Technologies, Inc. 87421A and 87422A power supplies are universal input, dc switching power supplies designed to provide the bias voltages needed to operate Keysight microwave system amplifiers.

These compact power supplies are ideal for integration into a system or for use on a benchtop.

The 2 meter dc bias cable permits the amplifier to be remotely located, allowing it to be placed out of the way or where space is not critical.

The 87421A is a 25 watt, $\pm 12\text{V}$ dc power supply designed to power the Keysight 83006A, 83017A, 83018A, and 87415A microwave system amplifiers. A 2 meter cable is included for direct connection to the amplifier.

The 87422A is a 90 watt, $\pm 15\text{V}$ dc power supply designed to power the Keysight 83020A microwave system power amplifier. One additional $\pm 12\text{V}$ dc output is provided to power a preamp such as the 83006A or 83017A.

Included with the power supply are the necessary 2 meter cables to connect to the amplifier.

The 87421A may also be used to provide bias voltages for the Keysight 83440C high speed lightwave converter. Using the 83440-60009 lightwave converter power supply adapter, the 87421A becomes a compact, convenient power supply for use with the lightwave converter.

- Designed specifically for Keysight microwave system amplifiers
- Bias cable permits remote placement
- Compact size for easy system integration

Product specifications

	Keysight 87421A	Keysight 87422A
Output voltage/current	+12V at 2 A –12V at 200 mA	+15V at 4.0 A –15V at 200 mA +12V at 2 A –12V at 200 mA
Output power	25 W	90 W
Line regulation	0.1%	0.1%
Load regulation (20% to full load)	2.0%	1.0%
Output ripple	25 mV RMS max	25 mV RMS max
Output noise	2% peak to peak max	2% peak to peak max
Overvoltage limit protected	Yes	Yes
Short circuit protection	Current limited for overload and short circuit protection. Normal operation returns upon removal of overload.	Current limited for overload and short circuit protection. Normal operation returns upon removal of overload.
General specifications		
AC input voltage	90–250 VAC, 50/60 Hz	90–240 VAC, 50/60 Hz
Fuse	1 A, slow blow	T 3.15 A
Weight	0.9 kg (2.0 lb)	2.1 kg (4.6 lb)
Shipping weight	1.8 kg (4.0 lb)	3.2 kg (7.0 lb)
Environmental specifications		
Operating temperature	0° to +55° C full load	0° to +55° C full load
Storage temperature	–40° to +70° C	–40° to +70° C

Other product and operating information

Operation of the power supplies involves connecting the power supplies output to the amplifier dc input with the cable provided. The power supplies include a power cord with protective ground for connection to 90–240 VAC.

Mounting holes are provided as shown in the outline drawings. The power supplies may be mounted in any orientation with user supplied hardware.

To ensure continued compliance to product safety and EMC specifications, connect the power supplies to an amplifier only with the cable provided. Do not attempt to modify or extend the dc output cable. For help with special applications requiring longer cables contact your Keysight call center listed on the back page.

The power supplies have a fuse located next to the IEC appliance inlet. If it is necessary to replace the fuse, disconnect the power supply from both AC power and the amplifier. Using a slotted screwdriver, open the fuse cover and replace the fuse.

The power supplies contain no user serviceable parts (with the exception of the fuse). If service is required, please contact your Keysight sales office or nearest Keysight Service Center.

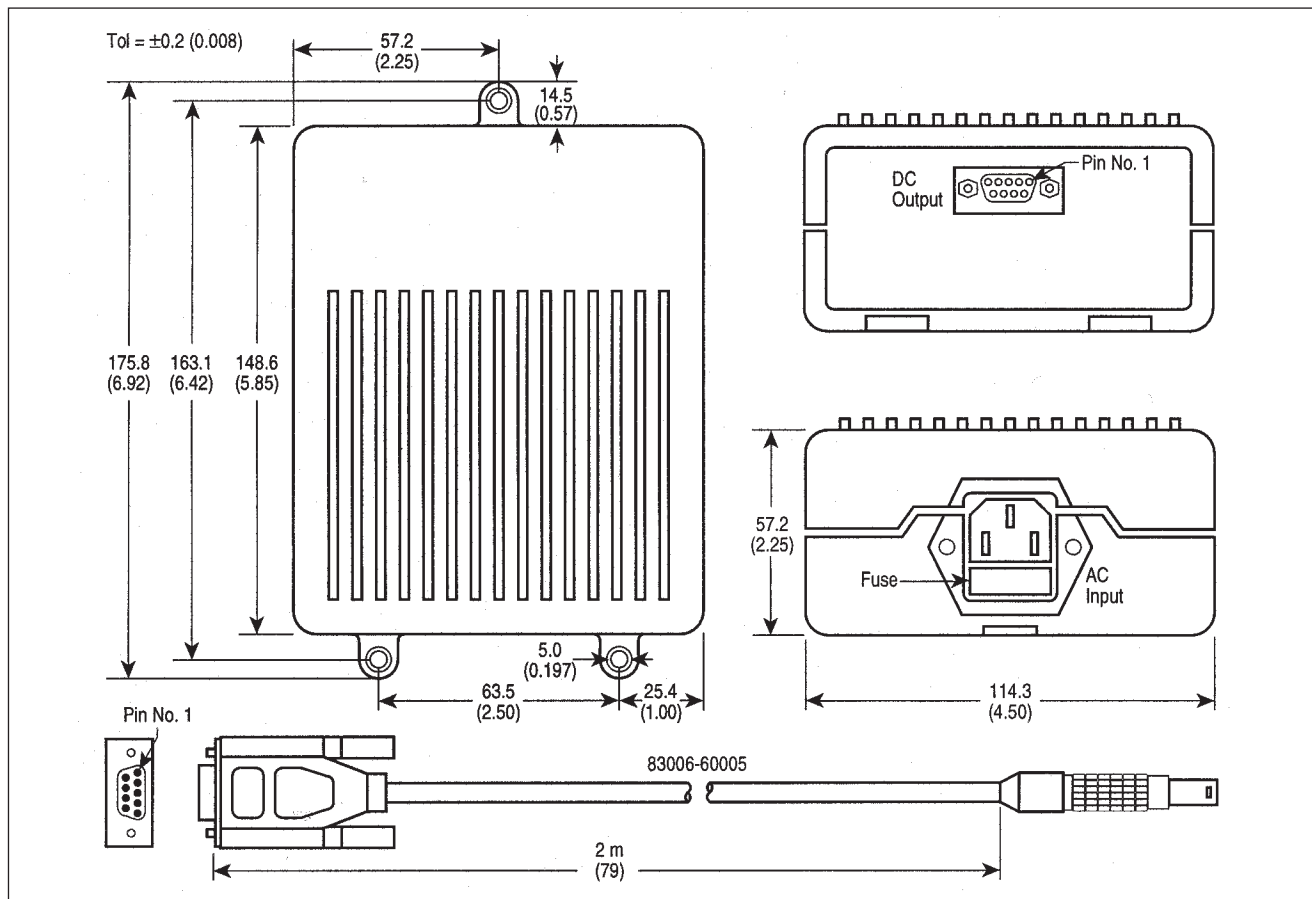

The Keysight 87421A power supply provides the dc power needed to bias the 83006A, 83017A, and 83018A. The power supply comes with a 2 meter long cable to allow easy connection between the amplifier and the power supply. Dimensions in millimeters and (inches).

Ordering information

Keysight 87421A power supply

Includes power supply, AC power cord, and part number 83006-60005, which is a 2 meter cable with a 3-pin connector on one end and a D-subminiature connector on the other end for direct connection to the Keysight 83006A, 83017A, 83018A, and 87415A microwave system amplifiers.

Keysight 87422A power supply

Includes power supply and part number 83020-60001, which is a 2 meter cable with 15-pin connectors for direct connection to the Keysight 83020A amplifier. One additional dc output is provided to supply power to a preamplifier such as the 83006A or 83017A.

Other instruments and accessories

Keysight 83006A Microwave System Amplifier, 0.01 to 26.5 GHz

Keysight 83017A Microwave System Amplifier, 0.5 to 26.5 GHz

Keysight 83018A Microwave System Amplifier, 2 to 26.5 GHz

Keysight 83020A Microwave System Power Amplifier, 2 to 26.5 GHz

Keysight 87415A Microwave System Amplifier, 2 to 8 GHz

Keysight 83440C High Speed Lightwave Converter, dc to 20 GHz, 1000 to 1600 nm

Keysight 83440-60009 Lightwave Converter Power Supply Adapter

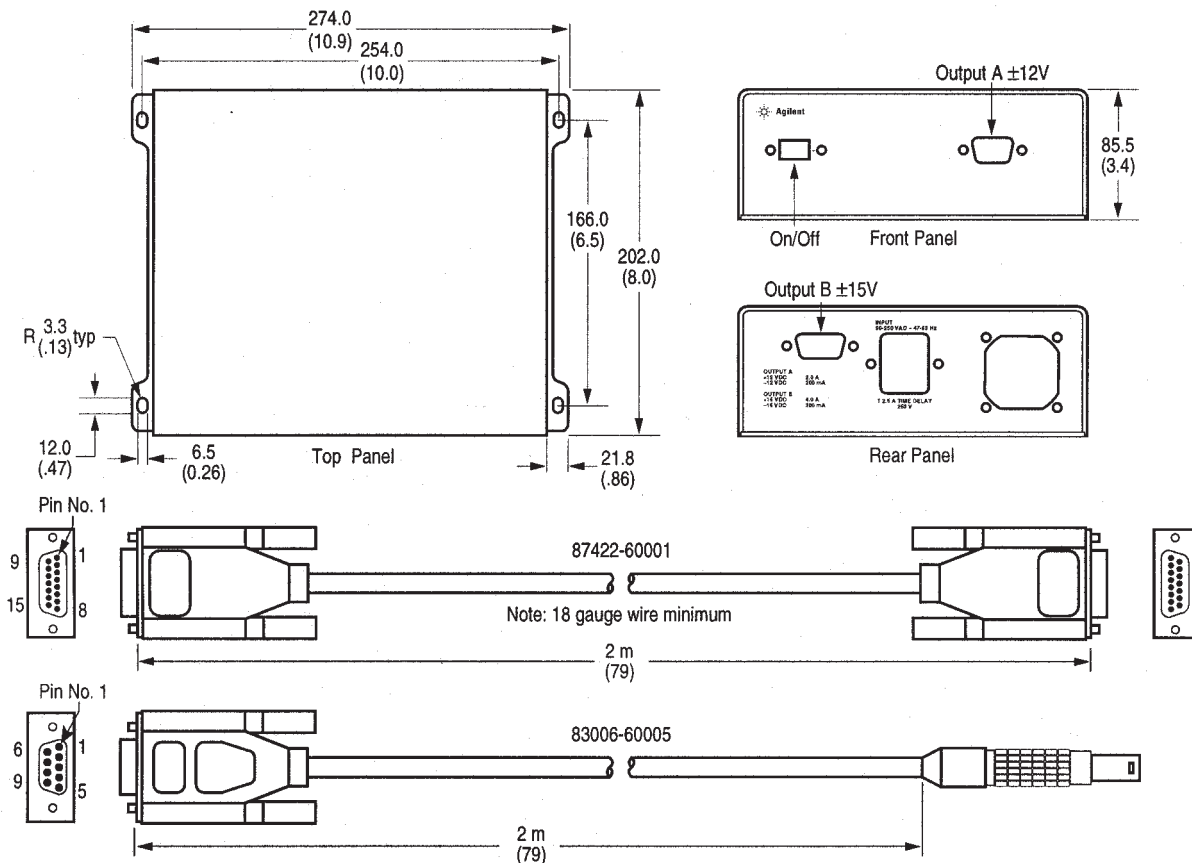

The Keysight 87422A power supply provides the dc power needed to bias the 83020A. DC cables shown above shipped with power supply. Dimensions in millimeters and (inches).

Safety and Regulatory Information

Manufacturer's Declaration

This is to certify that this product meets the requirements specified in IEC 1010 and IEC Publication 348, Safety Requirements for Electronic Measuring Apparatus. It has been supplied in a safe condition for indoor use only and may occasionally be subjected to temperatures between +5 and –10 Celsius without degradation of its safety. The present data sheet contains some information and warnings which have to be followed by the user to ensure safe operation and to retain the product in safe condition. The main plug shall be inserted in a socket outlet provided with a protective earth contact. The protective action must not be negated by the use of an extension cord without a protective conductor. **Warning:** Any interruption of the protective conductor inside or outside the product or disconnection of the protective earth terminal is likely to make the equipment dangerous. Intentional interruption is prohibited. This product has been designed to be safe under the following environmental conditions: indoor use; altitude up to 2,000 meters; temperature range expanded to include 0 to +55 Celsius; maximum relative humidity 80% up to 31 degrees Celsius decreasing linearly to 50% relative humidity at 40 degrees Celsius; mains supply voltage fluctuations not to exceed $\pm 10\%$ of nominal voltage; transient over voltage category II for the main ac supply voltage; pollution degree two. If the equipment is used in a manner not specified by Keysight Technologies, Inc. the protection provided by the equipment may be impaired.

Model 87422A

DECLARATION OF CONFORMITY

according to ISO/IEC Guide 22 and CEN/CENELEC EN 45014

Manufacturer's Name: Keysight Technologies, Inc.
Manufacturer's Address: 1400 Fountaingrove Parkway
Santa Rosa, CA 95403-1799
USA

Declares that the products

Product Name: Microwave System Amplifiers

Model Numbers: 83006A, 83017A, 83018A, 83020A, 83050A,
83051A, 87421A, and 87422A

Product Options: This declaration covers all options of the
above products.

Conform to the following product specifications:

EMC: IEC 61326:1997+A1:1998+A2:2000/ EN 61326:1997+A1:1998+A2:2001

<u>Standard</u>	<u>Limit</u>
CISPR 11:1997 / EN 55011:1998/A-1999	Group 1, Class A
IEC 61000-4-2:1995+A1998 / EN 61000-4-2:1995	4 kV CD, 8 kV AD
IEC 61000-4-3:1995 / EN 61000-4-3:1995	3 V/m, 80 - 1000 MHz
IEC 61000-4-4:1995 / EN 61000-4-4:1995	0.5 kV sig., 1 kV power
IEC 61000-4-5:1995 / EN 61000-4-5:1996	0.5 kV L-L, 1 kV L-G
IEC 61000-4-6:1996 / EN 61000-4-6:1998	3 V, 0.15 – 80 MHz
IEC 61000-4-11:1994 / EN 61000-4-11:1998	1 cycle, 100%

Supplementary Information:

The products herewith comply with the requirements of the Low Voltage Directive 73/23/EEC and the EMC Directive 89/336/EEC and carry the CE-marking accordingly.



Santa Rosa, CA, USA

25 November, 2002

Greg Pfeiffer/Quality Engineering Manager

For further information, please contact your local Keysight sales office, agent or distributor.

myKeysight

myKeysight

www.keysight.com/find/mykeysight

A personalized view into the information most relevant to you.



www.axiestandard.org

AdvancedTCA® Extensions for Instrumentation and Test (AXIe) is an open standard that extends the AdvancedTCA for general purpose and semiconductor test. Keysight is a founding member of the AXIe consortium. ATCA®, AdvancedTCA®, and the ATCA logo are registered US trademarks of the PCI Industrial Computer Manufacturers Group.



www.lxistandard.org

LAN eXtensions for Instruments puts the power of Ethernet and the Web inside your test systems. Keysight is a founding member of the LXI consortium.



www.pxisa.org

PCI eXtensions for Instrumentation (PXI) modular instrumentation delivers a rugged, PC-based high-performance measurement and automation system.



Three-Year Warranty

www.keysight.com/find/ThreeYearWarranty

Keysight's commitment to superior product quality and lower total cost of ownership. The only test and measurement company with three-year warranty standard on all instruments, worldwide.



Keysight Assurance Plans

www.keysight.com/find/AssurancePlans

Up to five years of protection and no budgetary surprises to ensure your instruments are operating to specification so you can rely on accurate measurements.



www.keysight.com/quality

Keysight Technologies, Inc.
DEKRA Certified ISO 9001:2008
Quality Management System

Keysight Channel Partners

www.keysight.com/find/channelpartners

Get the best of both worlds: Keysight's measurement expertise and product breadth, combined with channel partner convenience.

www.keysight.com/find/mta

For more information on Keysight Technologies' products, applications or services, please contact your local Keysight office. The complete list is available at: www.keysight.com/find/contactus

Americas

Canada	(877) 894 4414
Brazil	55 11 3351 7010
Mexico	001 800 254 2440
United States	(800) 829 4444

Asia Pacific

Australia	1 800 629 485
China	800 810 0189
Hong Kong	800 938 693
India	1 800 112 929
Japan	0120 (421) 345
Korea	080 769 0800
Malaysia	1 800 888 848
Singapore	1 800 375 8100
Taiwan	0800 047 866
Other AP Countries	(65) 6375 8100

Europe & Middle East

Austria	0800 001122
Belgium	0800 58580
Finland	0800 523252
France	0805 980333
Germany	0800 6270999
Ireland	1800 832700
Israel	1 809 343051
Italy	800 599100
Luxembourg	+32 800 58580
Netherlands	0800 0233200
Russia	8800 5009286
Spain	0800 000154
Sweden	0200 882255
Switzerland	0800 805353
	Opt. 1 (DE)
	Opt. 2 (FR)
	Opt. 3 (IT)
United Kingdom	0800 0260637

For other unlisted countries:
www.keysight.com/find/contactus
(BP-07-10-14)

