

- |               |  |               |   |               |   |               |   |               |   |                  |  |                  |   |                 |   |               |  |               |  |               |   |               |   |               |  |               |  |
|---------------|--|---------------|---|---------------|---|---------------|---|---------------|---|------------------|--|------------------|---|-----------------|---|---------------|--|---------------|--|---------------|---|---------------|---|---------------|--|---------------|--|
| <b>1</b><br>  | Needlenose Pliers<br>Pincès à bec effilé<br>Spitzzange<br>Pinzas de punta<br>Pinza a becchi piatti           | <b>2</b><br>  | Regular Pliers<br>Pincès réguliers<br>Normale Zange<br>Alcates de punta delgada | <b>3</b><br>  | Spring-action Needlenose Pliers<br>Pince à ressort à bec effilé<br>Spitzzange mit Federbetätigung<br>Alicate de punta delgada | <b>4</b><br>  | Spring-action Regular Pliers<br>Pince à ressort ordinaire<br>Normale Zange mit Federbetätigung<br>Alicate común | <b>5</b><br>  | Spring-action Wire Cutters<br>Cisailles / Coupe fils<br>(Hart-)Drahtschneider<br>Cortadores de alambre y de alambre duro<br>Pinza tagliafili/tagliacavi | <b>6</b><br>     | Wire Cutters<br>Cisailles / Coupe fils<br>(Hart-)Drahtschneider<br>Cortadores de alambre y de alambre duro<br>Pinza tagliafili/tagliacavi  | <b>7</b><br>     | Hard-wire Cutters<br>Cisailles / Coupe fils<br>(Hart-)Drahtschneider<br>Cortadores de alambre duro<br>Pinza tagliafili/tagliacavi | <b>8</b><br>    | Replaceable Wire Cutters<br>Pincès coupantes pour fil remplaçables<br>Auswechselbarer Drahtschneider  | <b>9</b><br>  | Replaceable Hard-wire Cutters<br>Pincès coupantes pour fil remplaçables<br>Auswechselbarer Drahtschneider<br>Cortadores de alambre | <b>10</b><br> | Stranded-wire Cutters<br>Pincès coupantes pour fils torsadés<br>Kabelschneider<br>Cortadores de alambre trenzado | <b>11</b><br> | Crimpers<br>Pincès à sertir<br>Presszange<br>Pinzas de enganche                           | <b>12</b><br> | Crimpers<br>Pincès à sertir<br>Presszange<br>Pinzas de enganche | <b>13</b><br> | Knife<br>Couteau<br>Messer<br>Hoja<br>Coltello   | <b>14</b><br> | Serrated Knife<br>Couteau cranté<br>Wellenschliffmesser<br>Hoja de filo serrada<br>Coltello seghettato<br>Gripelater kniv<br>Gekarteld mes |
| <b>15</b><br> | Scissors<br>Ciseaux<br>Schere<br>Tijeras<br>Forbici  | <b>16</b><br> | Saw<br>Scie<br>Säge<br>Sierra<br>Sega<br>Sag                                    | <b>17</b><br> | Diamond-coated File<br>Lime diamantée<br>Diamantbeschichtete Feile<br>Lima de diamante  | <b>18</b><br> | Wood/Metal File<br>Lime à bois/métal<br>Holz-/Metallfeile<br>Lima de madera/metal<br>Lima per legno/            | <b>19</b><br> | Cutting Hook<br>Crochet coupe corde<br>Aufbrechhaken<br>Cortador de gancho  | <b>20</b><br>    | Large Bit Driver<br>Adaptateur pour grand embout<br>Großer Bithalter<br>Soporte grande para puntas   | <b>21</b><br>    | Small Bit Driver<br>Adaptateur pour petit embout<br>Kleiner Bithalter<br>Soporte pequeño para puntas                              | <b>22</b><br>   | Phillips Screwdriver<br>Tournevis cruciforme<br>Kreuzschlitzschraubendreher<br>Destornillador   | <b>23</b><br> | Large Screwdriver<br>Tournevis grand<br>Großer Schraubendreher<br>Destornillador grande<br>Cacciavite grande                       | <b>24</b><br> | Med. Screwdriver<br>Tournevis moyen<br>Mittlerer Schraubendreher<br>Destornillador mediano<br>Cacciavite medio   | <b>25</b><br> | Small Screwdriver<br>Tournevis petit<br>Kleiner Schraubendreher<br>Destornillador pequeño | <b>26</b><br> | Awl<br>Pointon<br>Ahle<br>Punzón<br>Punteruolo<br>Syl           | <b>27</b><br> | Carabiner Tool<br>Outil avec mousqueton<br>Karabinertool<br>Mosquetón<br>Cottellino a moschetone | <b>28</b><br> | Package Opener<br>Coupe plastique<br>Plastikschneider<br>Cortador de plástico<br>Taglierno per plastica                                    |
| <b>29</b><br> | Hex Bit Driver<br>Adaptateur pour embout hexagonal<br>Sechskant-Bithalter<br>Soporte para puntas hexagonales | <b>30</b><br> | Ruler<br>Règle<br>Lineal<br>Regla<br>Righello                                   | <b>31</b><br> | Lanyard Ring<br>Anneau porte-dragonne<br>Anhängöse<br>Anilla de sujeción<br>Anello a rilascio rapido                          | <b>32</b><br> | Wire Stripper<br>Pincès coupe fils<br>Drahtschneider<br>Cortadores de alambre<br>Pinza tagliafili               | <b>33</b><br> | Can/Bottle Opener<br>Ouvre-bottes / Ouvre-bouteilles<br>Dosenöffner/Kapselheber<br>Abrelatas/abre-  | <b>420HC</b><br> | 420HC acciaio inossidabile<br>420HC Rustfritt stål<br>420HC roestvrij staal<br>Нержавеющая сталь<br>420HC<br>420HC 스테인레스 스틸<br>420HC 스텐레스 아cier inoxydable<br>420HC Edeltahl<br>De acero inoxidable<br>420HC | <b>154CM</b><br> | 154CM Stainless Steel<br>Acier inoxydable<br>154CM<br>154CM Edelstahl<br>De acero inoxidable<br>145CM                             | <b>S30V</b><br> | S30V® acciaio inossidabile<br>S30V® Rustfritt stål<br>S30V® roestvrij staal<br>Нержавеющая сталь S30V®<br>S30V® 스테인레스 스틸<br>S30V® 스텐레스 아cier inoxydable<br>S30V® Edeltahl<br>De acero inoxidable<br>S30V® |               |  |               |  |               |   |               |   |               |  |               |  |

- |                               |   |                                    |  |               |  |               |   |                  |  |                  |  |                 |   |
|-------------------------------|---|------------------------------------|--|---------------|--|---------------|---|------------------|--|------------------|--|-----------------|---|
| <b>All-locking Blades</b><br> | Dispositivo di blocco completo delle lame<br>Helltäsande blader<br>Vergrendelmessen<br>Лезвия с полной блокировкой<br>모든 잠금 칼날<br>로킹킹블레이드<br>全鎖刀片 | <b>One-hand Opening Blades</b><br> | Lame a sgancio rapido<br>Enhåndsöppning av blader<br>Met een hand te openen messen<br>Лезвия, открываемые одной рукой<br>한손 오픈 칼날<br>ワンハンドオープン 블레이드<br>Einhandöffnung<br>Hojas de apertura con una sola mano | <b>Ti</b><br> | titano<br>Titanbelegg<br>Titanium grip<br>Титановые накладки<br>티타늄 표면<br>チタン製スケール<br>鈦握把<br>鈦握把 | <b>AL</b><br> | 6061-T6 Aluminum Scales<br>Plaques des manches en aluminium<br>6061-T6 Griffschalen aus 6061-T6 Aluminium<br>Cachas de aluminio | <b>420HC</b><br> | 420HC Stainless Steel<br>Acier inoxydable<br>420HC<br>420HC Edeltahl<br>De acero inoxidable<br>420HC | <b>154CM</b><br> | 154CM acciaio inossidabile<br>154CM Rustfritt stål<br>154CM roestvrij staal<br>Нержавеющая сталь<br>154CM<br>154CM 스테인레스 스틸<br>154CM 스텐레스 아cier inoxydable<br>154CM Edeltahl<br>De acero inoxidable<br>145CM | <b>S30V</b><br> | S30V® acciaio inossidabile<br>S30V® Rustfritt stål<br>S30V® roestvrij staal<br>Нержавеющая сталь S30V®<br>S30V® 스테인레스 스틸<br>S30V® 스텐레스 아cier inoxydable<br>S30V® Edeltahl<br>De acero inoxidable<br>S30V® |
|-------------------------------|---|------------------------------------|--|---------------|--|---------------|---|------------------|--|------------------|--|-----------------|---|

## FULL-SIZE TOOL USER GUIDE

© 2011 LEATHERMAN TOOL GROUP, INC. 939765 1011

### USING THE WIRE CUTTERS

UTILISATION DES PINCES COUPE FILS  
VERWENDEN DES DRAHTSCHNEIDERS  
USO DE CORTADORES DE ALAMBRE  
UTILIZZO DELLA PINZA TAGLIAFILFI  
BRUKE AVBITERTENGER  
GEBRUIK VAN DE DRAADKNIPTANGEN  
ИСПОЛЬЗОВАНИЕ КУСАЧЕК ДЛЯ ПРОВОЛОКИ

와이어 커터 사용  
ワイヤーカッターの使用方法  
使用切线钳  
使用切線鉗

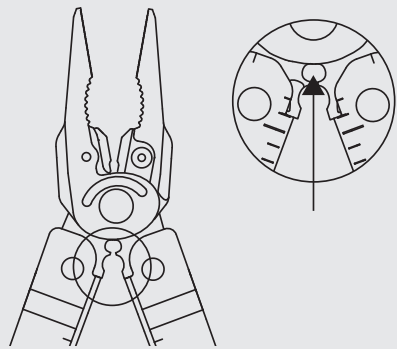
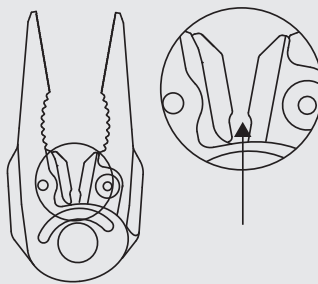

### OPENING BLADES AND LOCKS

OUVERTURE DES LAMES ET DES VERROUILLAGES  
ÖFFNEN DER WERKZEUGE UND ARRETIERUNGEN  
APERTURA DE LAS HOJAS Y SISTEMAS DE CIERRE  
APERTURA DELLE LAME E DEI DISPOSITIVI DI BLOCCO  
ÅPNE BLADER OG LÅSER  
MESSEN EN VERGRENDELINGEN OPENEN  
ОТКРЫВАНИЕ ЛЕЗВИЙ И ЗАМКОВ

칼날 오픈 및 잠금  
ブレードの開閉及びロック  
打开刀片和卡锁  
打開刀片和卡鎖

1

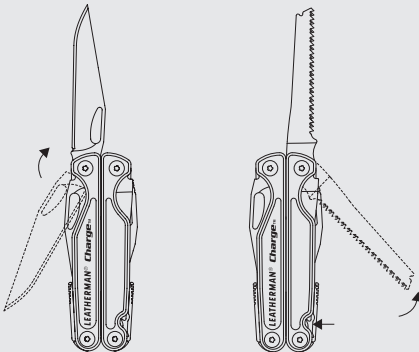

CHANGING BITS  
CHANGEMENT DES EMBOUTS  
AUSWECHSELN DER BITS  
CAMBIO DE PUNTAS  
CAMBIO DELLE PUNTE  
SKIFTE BITS  
VERWISSELEN VAN BITS  
ЗАМЕНА БИТ

비트 교환  
ビット交換  
换头  
換頭

1

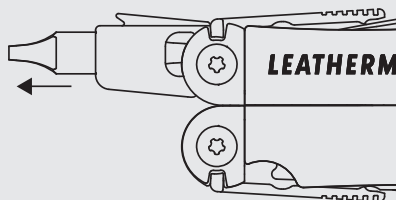

2

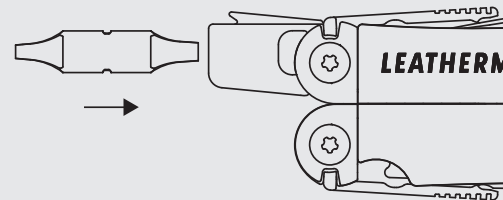

### REPLACING THE WIRE CUTTERS

REPLACEMENT DES PINCES COUPE FILS  
AUSWECHSELN DES DRAHTSCHNEIDERS  
SUSTITUCIÓN DE CORTADORES DE ALAMBRES  
SOSTITUZIONE DELLE PINZE TAGLIAFILFI  
SKIFTE UT AVBITERTENGER  
VERVANGEN VAN DE DRAADKNIPTANG  
ЗАМЕНА КУСАЧЕК ДЛЯ ПРОВОЛОКИ

와이어 커터 교체  
ワイヤーカッターの交換方法  
替换切线钳  
替換切線鉗

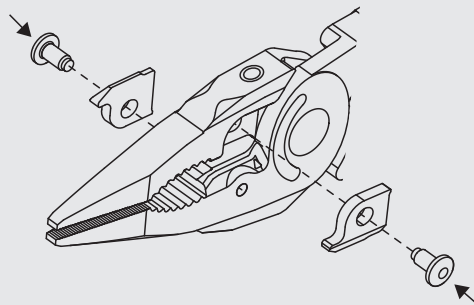

### PACKAGE OPENER

FPO REMPLACEMENT DES PINCES COUPE FILS  
FPO AUSWECHSELN DES DRAHTSCHNEIDERS  
FPO SUSTITUCIÓN DE CORTADORES DE ALAMBRES  
FPO SOSTITUZIONE DELLE PINZE TAGLIAFILFI  
FPO SKIFTE UT AVBITERTENGER  
FPO VERVANGEN VAN DE DRAADKNIPTANG  
FPO ЗАМЕНА КУСАЧЕК ДЛЯ ПРОВОЛОКИ

FPO 와이어 커터 교체  
FPO ワイヤーカッターの交換方法  
FPO 替换切线钳  
FPO 替換切線鉗

