

FLUKE®

Calibration

7102

Micro-Bath

User's Guide

LIMITED WARRANTY AND LIMITATION OF LIABILITY

Each Fluke product is warranted to be free from defects in material and workmanship under normal use and service. The warranty period is one year and begins on the date of shipment. Parts, product repairs, and services are warranted for 90 days. This warranty extends only to the original buyer or end-user customer of a Fluke authorized reseller, and does not apply to fuses, disposable batteries, or to any product which, in Fluke's opinion, has been misused, altered, neglected, contaminated, or damaged by accident or abnormal conditions of operation or handling. Fluke warrants that software will operate substantially in accordance with its functional specifications for 90 days and that it has been properly recorded on non-defective media. Fluke does not warrant that software will be error free or operate without interruption.

Fluke authorized resellers shall extend this warranty on new and unused products to end-user customers only but have no authority to extend a greater or different warranty on behalf of Fluke. Warranty support is available only if product is purchased through a Fluke authorized sales outlet or Buyer has paid the applicable international price. Fluke reserves the right to invoice Buyer for importation costs of repair/replacement parts when product purchased in one country is submitted for repair in another country.

Fluke's warranty obligation is limited, at Fluke's option, to refund of the purchase price, free of charge repair, or replacement of a defective product which is returned to a Fluke authorized service center within the warranty period.

To obtain warranty service, contact your nearest Fluke authorized service center to obtain return authorization information, then send the product to that service center, with a description of the difficulty, postage and insurance prepaid (FOB Destination). Fluke assumes no risk for damage in transit. Following warranty repair, the product will be returned to Buyer, transportation prepaid (FOB Destination). If Fluke determines that failure was caused by neglect, misuse, contamination, alteration, accident, or abnormal condition of operation or handling, including overvoltage failures caused by use outside the product's specified rating, or normal wear and tear of mechanical components, Fluke will provide an estimate of repair costs and obtain authorization before commencing the work. Following repair, the product will be returned to the Buyer transportation prepaid and the Buyer will be billed for the repair and return transportation charges (FOB Shipping Point).

THIS WARRANTY IS BUYER'S SOLE AND EXCLUSIVE REMEDY AND IS IN LIEU OF ALL OTHER WARRANTIES, EXPRESS OR IMPLIED, INCLUDING BUT NOT LIMITED TO ANY IMPLIED WARRANTY OF MERCHANTABILITY OR FITNESS FOR A PARTICULAR PURPOSE. FLUKE SHALL NOT BE LIABLE FOR ANY SPECIAL, INDIRECT, INCIDENTAL, OR CONSEQUENTIAL DAMAGES OR LOSSES, INCLUDING LOSS OF DATA, ARISING FROM ANY CAUSE OR THEORY.

Since some countries or states do not allow limitation of the term of an implied warranty, or exclusion or limitation of incidental or consequential damages, the limitations and exclusions of this warranty may not apply to every buyer. If any provision of this Warranty is held invalid or unenforceable by a court or other decision-maker of competent jurisdiction, such holding will not affect the validity or enforceability of any other provision.

Fluke Corporation
P.O. Box 9090
Everett, WA 98206-9090
U.S.A.

Fluke Europe B. V.
P.O. Box 1186
5602 BD Eindhoven
The Netherlands

Table of Contents

Title	Page
Introduction.....	1
Safety Information	2
Contact Fluke Calibration	3
Service Information.....	3
Specifications	4
Environmental Conditions.....	5
Quick Start.....	5
Unpacking.....	5
Bath Environment	5
Bath Fluids (Summary).....	6
Installation	6
Power	7
Thermal Electric Devices.....	7
Set the Temperature.....	8
Bath Use.....	8
Parts and Controls.....	9
Front Panel	9
Back Panel.....	10
Accessories	11
Transport/Pour Access Lid	11
Access Cover (Optional).....	12
Probe Basket	12
Stir Bar.....	13
Well Extender (Optional).....	13
Comparison Calibration.....	13
Calibration of Multiple Probes.....	14
General Operation	14
Change Display Units	14
Bath Fluid.....	14
Temperature Range.....	14
Viscosity.....	15
Specific Heat.....	15
Thermal Conductivity	15
Thermal Expansion.....	15
Electrical Resistivity	15

Fluid Lifetime	15
Safety	16
Cost	16
Commonly Used Fluids.....	16
Mineral Oil.....	16
Silicone Oil (Dow Corning 200.05, 200.10, 200.20).....	16
Fluid Characteristics Charts.....	17
Limitations and Disclaimer	18
About the Graph.....	19
Stirring	19
Fluid Drain	20
Temperature Controller	20
Controller Operation	20
Well Temperature	21
Temperature Set-point	21
Programmable Set-points	21
Set-point Value	21
Temperature Scale Units	23
Scan	23
Scan Control.....	23
Scan Rate.....	24
Temperature Display Hold.....	24
Mode Setting	25
Switch Wiring.....	25
Switch Test Example	25
Secondary Menu	26
Thermal Electric Device (TED).....	26
Proportional Band.....	26
Controller Configuration	27
Operating Parameters	27
High Limit	27
Stir Speed	28
Serial Interface Parameters.....	28
BAUD Rate	28
Sample Period	28
Duplex Mode.....	29
Linefeed	29
Calibration Parameters	29
R0	30
ALPHA	30
DELTA	30
C0 and CG	30
rCAL.....	30
Digital Communication Interface	30
Serial Communications	31
Wiring	31
Setup	31
Serial Operation.....	31
Interface Commands	31
Calibrate a Single Probe	33

Stabilization and Accuracy	34
Calibration	34
Calibration Points	34
Calibration Procedure	35
Compute DELTA.....	35
Compute R0 & ALPHA	36
Accuracy and Repeatability	36
Maintenance	36
Troubleshooting Problems, Possible Causes, and Solutions	37

Introduction

The Fluke Calibration 7102 Micro-Bath (the Product, calibrator, or instrument) is a portable instrument/ bench-top temperature calibrator. Use the Product to calibrate thermocouple and RTD temperature probes. The Product is small enough to use in the field, and accurate enough to use in the lab. With an ambient temperature of 23 °C (74 °F), calibrate over a range of –5 °C to 125 °C (23 °F to 257 °F). The resolution of the display is 0.01 degrees.

The Product features:

- Convenient handle
- RS-232 interface
- Universal ac input (115 VAC or 230 VAC)
- Optional well extender to extend well depth

Built in programmable features include:

- Temperature scan rate control
- Temperature switch hold
- Eight Set-point memory
- Adjustable readout in °C or °F

The temperature is accurately controlled by a hybrid analog/digital controller. The controller uses a precision platinum RTD as a sensor and controls the well temperature with a solid-state relay (triac) driven heater.

The LED front panel (display) continuously shows the current well temperature. Set the temperature with the control keys to any desired temperature within the specified range. Multiple fault protection devices ensure user and Product safety and protection.

Through proper use, the Product continuously provides accurate calibration of temperature sensors and devices.

Safety Information

General Safety Information is in the printed *Safety Information* document that shipped with the Product. It can also be found online at www.Flukecal.com. More specific safety information is listed in this manual where applicable.

A **Warning** identifies conditions and procedures that are dangerous to the user. A **Caution** identifies conditions and procedures that can cause damage to the Product or the device under test (DUT).

Cautions

To avoid possible damage to the Product, follow these guidelines:

- **Never introduce any foreign material into the well.**
- **Do not change the values of the calibration constants from the factory set values. The correct setting of these parameters is important to the safety and proper operation of the unit.**
- **Do not slam the probe stems into the well. This type of action can cause a shock to the sensor and affect the calibration.**
- **Always use a ground fault interrupt device.**
- **The unit is a precision instrument. Although it has optimum durability and trouble-free operation, it must be handled with care.**
- **Most probes have handle temperature limits. Be sure that the probe handle temperature limit is not exceeded in the air above the instrument.**
- **The instrument and any thermometer probes used with it are sensitive instruments that can be easily damaged. Always handle these devices with care. Do not allow them to be dropped, struck, stressed, or overheated.**
- **When you calibrate PRTs always follow correct calibration procedure and calibrate from high temperatures to low temperatures with the appropriate triple point of water checks.**
- **Components and heater lifetimes can be shortened by continuous high temperature operation.**

- If a mains supply power fluctuation occurs, immediately turn off the bath. Power bumps from brown-outs and black-outs can damage the instrument. Wait until the power has stabilized before re-energizing the bath.
- Fluke Calibration does not recommend the use of water as a fluid in the Product. If the tank coating is compromised, galvanic corrosion will occur due to dissimilar metals and the presence of water (electrolyte).

Note

Disregard any references to the use of water as a bath fluid in this manual.

Contact Fluke Calibration

Fluke Corporation operates worldwide. For local contact information, go to our website:

www.flukecal.com

To register your product, view, print, or download the latest manual or manual supplement, go to our website.

Fluke Corporation
P.O. Box 9090
Everett, WA 98206-9090

+1-425-446-5500
info@flukecal.com

Service Information

Contact an authorized Fluke Calibration Service Center if the Product needs calibration or repair during the warranty period. Please have Product information such as the purchase date and serial number ready when you schedule a repair.

Specifications

Table 1. Specifications

Range	-5 °C to 125 °C (23 °F to 257 °F)
Accuracy	±0.25 °C
Stability	±0.015 °C at -5 °C (oil, 5010) ±0.03 °C at 121 °C (oil, 5010)
Uniformity	±0.02 °C
Resolution	0.01 °C/F
Operating Temperature	5 °C to 45 °C (41 °F to 113 °F)
Heating Time	25 °C to 100 °C (77 °F to 212 °F): 30 minutes
Cooling Time	25 °C to 0 °C (77 °F to 32 °F): 30 minutes
Well Size	64 x 139 mm deep (2.5 in dia. x 5.5 in) (access opening is 48 mm [1.9 in] in diameter)
Exterior Dimension	31 cm x 18 cm x 24 cm (12 in H x 7.2 in W x 9.5 in D)
Weight	6.8 kg (15 lb) with fluid
Power	115/230 VAC (±10 %), 50/60 Hz, 300 VA
Fuse Rating	T, 4 A, 250 V
Readout	Switchable °C or °F
Controller	Digital controller with data retention
Thermal Electric Devices (TED)	150 W
Cooling	Fan and Thermal Electric Devices (TED)
Environmental Conditions	
Ambient Temperature Range	5 °C to 45 °C (41 °F to 113 °F)
Ambient Relative Humidity	maximum 80 % for temperature <31 °C, decreasing linearly to 35 % at 45 °C
Altitude	<2000 m
Fault Protection	Sensor burnout and short protection
Safety	
General Heating	IEC 61010-1: Overvoltage Category II, Pollution Degree 2 IEC 61010-2-010
Electromagnetic Compatibility (EMC)	International.....IEC 61326-1: Basic Electromagnetic Environment CISPR 11: Group 1, Class A <i>Group 1: Equipment has intentionally generated and/or uses conductively-coupled radio frequency energy that is necessary for the internal function of the equipment itself. Class A: Equipment is suitable for use in all establishments other than domestic and those directly connected to a low-voltage power supply network that supplies buildings used for domestic purposes. There may be potential difficulties in ensuring electromagnetic compatibility in other environments due to conducted and radiated disturbances. Caution: This equipment is not intended for use in residential environments and may not provide adequate protection to radio reception in such environments.</i> Korea (KCC).....Class A Equipment (Industrial, Broadcasting, & Communication Equipment) <i>Class A: Equipment meets requirements for industrial electromagnetic wave equipment and the seller or user should take notice of it. This equipment is intended for use in business environments and not to be used in homes.</i> USA (FCC)47 CFR 15 subpart B. This product is considered an exempt device per clause 15.10

Environmental Conditions

See [Safety Information](#) for cautions that deal with environmental conditions. Maintenance and cleaning recommendations can be found in [Maintenance](#). Vibrations in the calibration environment should be minimized, see [Bath Environment](#).

Quick Start



Read [Bath Use](#) before placing the bath in service. Incorrect handling can damage the Product and void the warranty.

Unpacking

Unpack the Product carefully and inspect it for any damage that may have occurred during shipment. If there is shipping damage, notify the carrier immediately.

Verify that these components are present:

- 7102 Micro-Bath
- *7102/7103 Safety Information*
- Transport/Pour Access Lid
- Probe Basket
- Stir Bar
- Power Cord
- Report of Calibration
- Calibration Label
- Access Cover, optional
- Well Extender, optional

Bath Environment

Locate the Product in an appropriate environment. Make sure that the location is free of drafts, extreme temperatures, temperature changes, and contaminants. Place the bath on a heat-proof surface such as concrete with at least 15 cm (6 in) of clearance around the bath. Beware of the danger of accidental fluid spills.

 **Warning**

To prevent personal injury:

- **Be aware that the Product operates at high temperatures.**
- **Keep all flammable and meltable materials away from the Product.**
- **Although the Product is well insulated, top surfaces become hot.**
- **If the bath is operated at high temperatures, use a fume hood to remove any vapors given off by hot bath fluid.**

Bath Fluids (Summary)

The Product does not come with fluid. Various fluids are available from Fluke Calibration and other sources. To safely operate the Product, only select bath fluids with adequate thermal properties that meet the application requirements.

Depending on the desired temperature range, any of these fluids, as well as others, can be used:

- Ethylene glycol
- Mineral oil
- Silicone oil

See [Bath Fluid](#) and its subsections for information on fluid selection. See the specific MSDS sheet for each fluid selected.

Installation

 **Caution**

- **Read [Bath Use](#) before you place the bath into service. incorrect handling can damage the Product and void the warranty.**
- **Do not operate this Product without fluid.**
- **Make sure that the tank is 3/4 full before you set the temperature.**

To install the Product:

1. Remove the access lid from the bath and check the tank for foreign matter (for example, dirt or remnant packing material). Before you fill the well, thoroughly dry the inside of the well with paper towels.
2. Plug the power cord into a grounded mains outlet. Observe that the nominal voltage corresponds to that indicated on the back of the Product.
3. Carefully insert the probe basket into the well, then insert the probe(s) into the basket.
4. With the probe(s) in the well, fill the tank 3/4 full with the appropriate, clean fluid.

5. Power on the Product. Toggle the switch on the power entry module (PEM), see Figure 2. The fan blows air through the Product and the display illuminates after 3 seconds. After a brief self test, the Product begins normal operation. If the Product fails to operate, check the power connection.
6. Heat to the maximum temperature of the fluid. See [Set the Temperature](#).
7. Slowly fill the well to 2.5 cm (1 in) below the top of the basket at the maximum temperature of the fluid.

⚠ Caution

Be aware that some fluids expand and could overflow the bath if not watched, see [Bath Fluid](#) and its subsections for more information.

The set-point temperature and the number of and size of the probes determine the fluid level. Under-filling can reduce bath performance. Always keep the fluid level at least 2 cm (0.75 in) below the top of the well to prevent overflow of the fluid when you insert the probes. For example, if you place silicone oil 200.05 at room temperature, 25 °C (77 °F), into the bath and heat to 125 °C, this causes a 2.5 cm (1 in) expansion of the fluid inside the well.

The display shows the well temperature. The well Thermal Electric Devices (TEDs) bring the temperature of the well to the setpoint temperature. Make sure that the fluid is being stirred.

Power

The ac mains supply provides power to the bath and passes through a filter to prevent the transmission of switching spikes to other equipment. Refer to [Specifications](#) for power details.

When powered on, the display briefly shows a four-digit number. This number indicates the number of times power was applied to the bath. Also, briefly displayed, is data which indicates the controller hardware configuration. Use this data in some circumstances for diagnostic purposes.

Thermal Electric Devices

The temperature controller precisely controls the bath power to maintain a constant bath temperature. Power is controlled by periodically switching the TEDs on for a certain amount of time with power transistors.

Set the Temperature

Temperature Set-point explains how to set the calibrator temperature set-point with the front panel keys. Briefly, the procedure is:

1. Push **SET** twice to access the set-point value.
2. Push **UP** or **DOWN** to change the set-point value.
3. Push **SET** to store the new set-point.
4. Push **EXIT** to return to the temperature display.

When the set-point temperature changes, the heater switches on or off to raise or lower the temperature. The well temperature gradually changes until it reaches the set-point temperature. The well can require 25 minutes to reach the set-point, depending on the span. Another 10 minutes to 15 minutes is required to stabilize within ± 0.03 °C of the set-point. Ultimate stability can take 20 minutes to 30 minutes more of stabilization time.

Bath Use

Read this section before you place the bath in service.

The information in this section is for general information only. Do not use this section as the basis for calibration laboratory procedures. Each laboratory must write their own specific procedures.

Generally, baths are set to one temperature and used to calibrate probes only at that single temperature. This means that the type of bath fluid does not have to change. Additionally, leave the bath energized to reduce the stress on the system.

Select the correct fluid for the temperature range of the calibration. You must select bath fluids to operate safely with adequate thermal properties to meet the application requirements. Be aware that some fluids expand and could overflow the bath if not watched, see *Bath Fluid* and its subsections for information specific to fluid selection and see the MSDS sheet specific to the fluid selected.

Warning

To prevent possible fire, or personal injury:

- **Use care to prevent personal injury or damage to objects. The bath generates extreme temperatures.**
- **Carefully place probes on a heat/cold resistant surface or rack until they are at room temperature. Probes can be extremely hot or cold when removed from the bath.**
- **Wipe the probe with a clean, soft cloth or paper towel before you insert it into another bath. This prevents the contamination of fluids from one bath to another.**
- **Be aware that cleaning the probe can be dangerous if the probe has not cooled to room temperature. Additionally, high temperature fluids can ignite the paper towels if the probe has not been cooled.**
- **Be aware some of the high temperature fluids react violently to water or other liquid mediums.**

If the probe was calibrated in liquid salt, carefully wash the probe in warm water and dry completely before you transfer it to another fluid. Always be sure that the probe is completely dry before you insert it into a hot fluid.

For optimum accuracy and stability, allow the bath adequate stabilization time after it reaches the set-point temperature.

Parts and Controls

This section describes the bath and its parts.

Front Panel

This section describes and shows the front panel. See Figure 1.

Figure 1. 7102 Front Panel

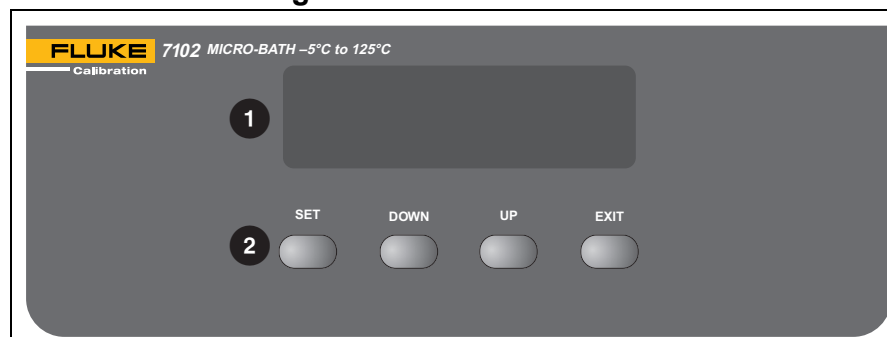

Controller Display (1) – The digital display not only shows set and actual temperatures but also shows various calibrator functions, settings, and constants. The display shows temperatures in units according to the selected scale °C or °F.

Controller Keypad (2) – Use the keys (**SET**, **DOWN**, **UP**, and **EXIT**) to set the calibrator temperature set-point, access and set other operating parameters, and access and set calibration parameters.

Set the control temperature directly in degrees of the current scale. You can set the temperature to one-hundredth of a degree Celsius or Fahrenheit.

The functions of the keys are:

SET – Shows the next parameter in the menu and stores parameters to the value.

DOWN – Decrements the shown value of parameters.

UP – Increments the shown value.

EXIT – Exits a function. Any changes made to the value shown are ignored. Hold **EXIT** for approximately 0.5 seconds to exit back to the main display.

Back Panel

This section describes and shows the back panel. See Figure 2.

Figure 2. 7102 Back Panel

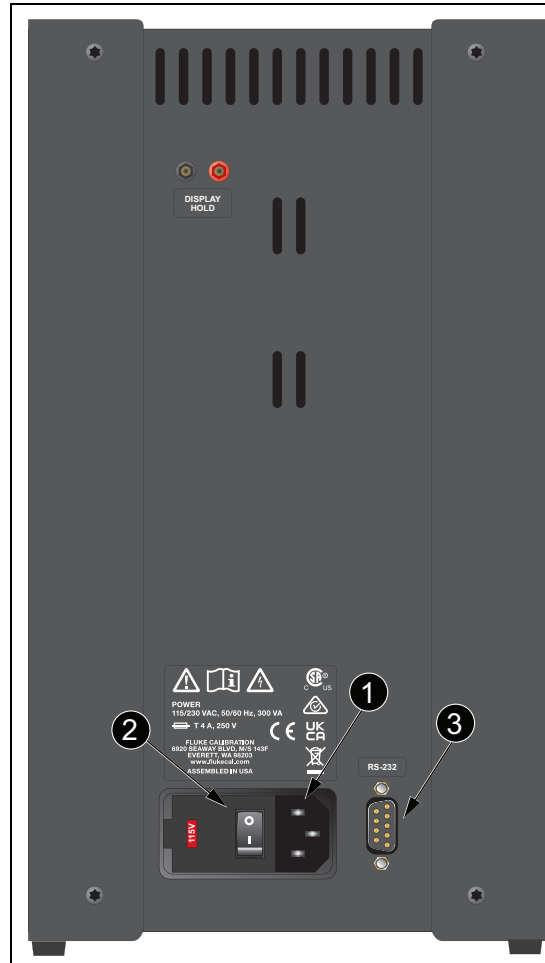

Power Cord – Underneath the calibrator is the removable power cord inlet that plugs into an IEC grounded socket (1).

Power Switch (2) – The power switch is on the power entry module (PEM). The PEM also houses the fuses and the dual voltage selector (most models). The PEM allows most units to be field switchable for 115 VAC ($\pm 10\%$) or 230 VAC ($\pm 10\%$) operation.

Serial Port (3) – Use the DB-9 male connector to interface the calibrator to a computer or terminal with serial RS-232 communications.

Fan – The fan inside the calibrator runs continuously to cool the Product. Slots at the top and around the two corners of the calibrator provide airflow. Keep the area around the calibrator clear to allow adequate ventilation out of the back.

Accessories

Transport/Pour Access Lid

Use the provided transport/pour access lid (see Table 2) to keep the fluid in the bath when transporting.

Table 2. Bath Lids and Lid Parts

The diagram shows six numbered parts of the bath lid assembly. Part 1 is a threaded pour spout with a tapered top. Part 2 is a cylindrical cover for the spout. Part 3 is a threaded transport plug. Part 4 is a circular lid with a central hole and a flange. Part 5 is an optional access cover with a flange. Part 6 is a guide ring, shown as a concentric circle on the lid.

Item	Description	Item	Description
1	Pour Spout	4	Transport/Pour Access Lid
2	Pour Spout Cover	5	Optional Access Cover
3	Transport Plug	6	Guide Ring

Access Cover (Optional)

An aluminum access cover (see Table 2) is available for optimum stability. Drill holes into the access cover to insert the probes into the well. The holes must be within the guide ring for the probes to fit into the probe basket.

⚠ Warning

Do not install an access cover without holes (like the optional cover) onto a bath that is energized. Dangerous pressures may result from fluids vaporizing.

Probe Basket

A probe basket (Figure 3) provides a guide for the probes and prevents bumping of the stir bar.

Figure 3. Probe Basket

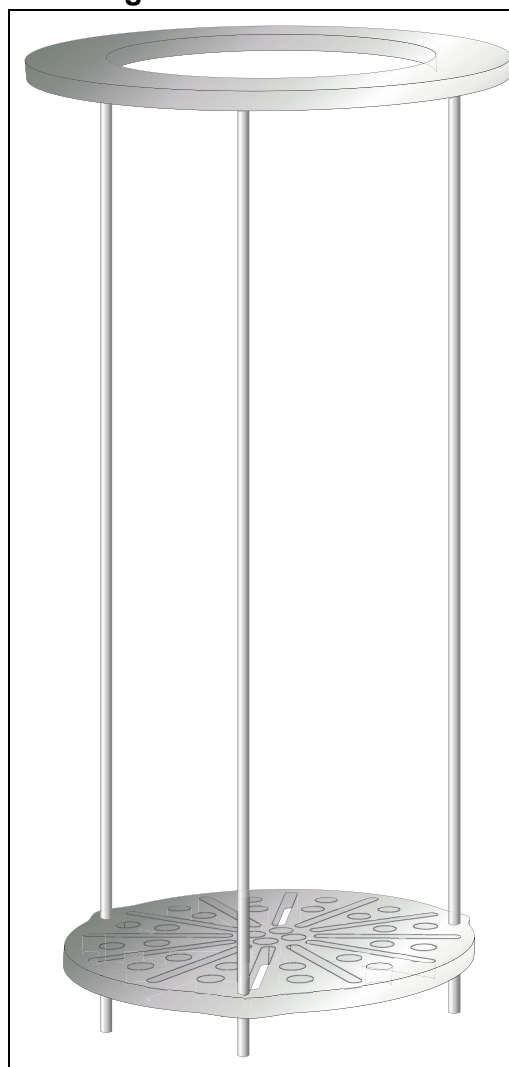

Stir Bar

The stir bar (Figure 4) sits in the bottom of the well for mixing the fluid providing better accuracy, uniformity, and stability.

Figure 4. Stir Bar

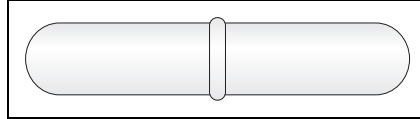

Well Extender (Optional)

An optional well extender is available to increase the depth of the well. The extender screws onto the well and features an O-ring. Thread the extender down until the O-ring makes a good seal. Some fluids may expand up to 6.35 cm (2.5 in). Therefore, when you use the well extender, keep in mind how much the fluid in use expands. Do not overfill the well.

Comparison Calibration

Comparison calibration involves testing a probe (Device Under Test, DUT) against a reference probe. After you insert the DUT into the bath, allow sufficient time for the probes to settle and the temperature of the bath to stabilize.

One significant benefit of bath use rather than a dry-well to calibrate multiple probes is that the probes do not need to be identically constructed. The fluid in the bath allows you to calibrate different types of probes at the same time. However, stem effect from different types of probes is not completely eliminated. Even though all baths have horizontal and vertical gradients, these gradients are minimized inside the bath work area. Nevertheless, make sure to insert probes to the same depth in the bath liquid. Be sure that all probes are inserted deep enough to prevent stem effect. Fluke Calibration recommends a general rule for immersion depth to reduce the stem effect to a minimum: $20 \times$ the diameter of the DUT + the sensor length. Do not submerge the probe handles. If the probe handles get too warm during calibration at high temperatures, use a heat shield just below the probe handle. This heat shield could be as simple as aluminum foil placed between the probe handle and above the bath before you insert it in the bath or as complicated as a specially designed reflective metal apparatus.

For best results when you calibrate over a wide temperature range, start at the lowest temperature and progress to the highest temperature.

Use probe clamps or drill holes in the access cover to hold probes in place. Other fixtures to hold the probes can be designed. Keep the reference probe and the probe(s) to be calibrated as closely grouped as possible (while allowing adequate spacing for fluid to pass between the probes) in the working area. For maximum bath stability, keep the working area covered.

To prepare for calibration:

- Place the reference probe in the bath working area.
- Place the DUT in the bath working area as close as possible to the reference probe.

Calibration of Multiple Probes

Fully loading the bath with probes increases the required probe temperature stabilization. Use the reference probe as the guide to make sure that the temperature has stabilized before you start the calibration.

General Operation

Change Display Units

The temperature units are factory defaulted to Celsius. To change to Fahrenheit or back to Celsius:

1. Push **SET** and **UP** simultaneously. The temperature display changes units.
2. Push **SET** three times to store the changes. The display shows:

Un=C

or

1. Push **UP** or **DOWN** to change units.
2. Push **SET** to store the changes.

Bath Fluid

Many fluids work with the Product. When you choose a fluid consider the many important characteristics of the fluid. Among these are temperature range, viscosity, specific heat, thermal conductivity, thermal expansion, electrical resistivity, fluid lifetime, safety, and cost. The next sections explain each of these characteristics in detail.

Temperature Range

An important characteristic to consider is the temperature range of the fluid. Few fluids work well throughout the complete temperature range of the bath. The bath operating temperature must always be within the safe and useful temperature range of the fluid. The freeze point of the fluid or the temperature at which the viscosity becomes too great determines the lower temperature range of the fluid. The upper temperature is usually limited by vaporization, flammability, or chemical breakdown of the fluid. Vaporization of the fluid at higher temperatures can affect temperature stability because of cool condensed fluid that drips into the bath from the lid.

Viscosity

Viscosity is the thickness measurement of a fluid and how easily it can be poured and mixed. Viscosity affects the temperature stability of the bath. Fluid mixing is better with low viscosity and this creates a more uniform temperature throughout the bath. If the bath temperature is more uniform, the bath response time is better. Viscosity should be <10 centistokes for good control. The upper limit of allowable viscosity is about 20 centistokes. Viscosities greater than this cause poor control stability. With oils, viscosity varies greatly with temperature.

With higher-viscosity fluids, the controller proportional band could need to be increased to compensate for the reduced response time. Otherwise, the temperature could oscillate.

Specific Heat

Specific heat is the measure of the heat storage ability of the fluid. Specific heat, to a small degree, affects the control stability and affects the heating and cooling rates. Generally, a lower specific heat means quicker heat and cool down times. Adjust the proportional band, depending on the specific heat of the fluid, when necessary.

Thermal Conductivity

Thermal conductivity measures how easily heat flows through the fluid. Thermal conductivity of the fluid affects the control stability, temperature uniformity, and probe temperature settling time. Fluids with higher conductivity distribute heat faster and more evenly which improves bath performance.

Thermal Expansion

Thermal expansion is how the volume of the fluid changes with temperature. Thermal expansion of all fluids used must be considered since the increase in fluid volume (as the bath temperature changes) may cause overflow. Excessive thermal expansion may also be undesirable in applications where constant liquid level is important. Many fluids, oils included, have significant thermal expansion.

Electrical Resistivity

Electrical resistivity is how well the fluid insulates against the flow of electric current. In some applications, measuring the resistance of bare temperature sensors, for example, it is important that little or no electrical leakage occurs through the fluid. In such conditions, choose a fluid with a high resistivity.

Fluid Lifetime

Many fluids degrade over time because of evaporation, water absorption, gelling, or chemical breakdown. Often the degradation becomes significant near the upper temperature limit of the fluid and this substantially reduces the lifetime of the fluid.

Safety

Always consider the safety issues associated with any fluid. Where there are conditions of extreme hot or cold, there can be danger to people and equipment. Fluids can be hazardous for other reasons. Some fluids are considered toxic. Contact with eyes, skin, or inhalation of vapors can cause injury.

Warning

To prevent personal injury, be aware that fluids at high temperatures can cause burns, fire, and toxic fumes. Use caution and safety equipment. Use a proper fume hood if hazardous or bothersome vapors are produced.

Some fluids are flammable and require special fire safety equipment and procedures. Always consider the flash point of the fluid. The flash point is the temperature at which sufficient vapor is produced that, when mixed with sufficient oxygen and an ignition source, ignites the vapor. This does not necessarily mean that fire is sustained at the flash point. In a bath environment, the flash point can be either the open-cup or closed-cup type. The closed-cup temperature is always the lower of the two. The closed cup represents the contained vapors inside the tank. The open-cup temperature represents the vapors that escape the tank. Oxygen and an ignition source are less available inside the tank.

Environmentally hazardous fluids require special disposal according to applicable federal or local laws after use.

Cost

Cost of bath fluids varies greatly. Cost is an important consideration with bath fluids.

Commonly Used Fluids

A description of some of the more commonly used fluids and their characteristics are in the subsequent sections.

Mineral Oil

Mineral oil or paraffin oil is often used at moderate temperatures above the range of water. Mineral oil is inexpensive. At lower temperatures, mineral oil is quite viscous, and control can be poor. At higher temperatures, vapor emission is significant. The vapors can be dangerous, and Fluke Calibration highly recommends a fume hood. As with most oils, mineral oil expands as temperature increases so do not fill the bath so full that it overflows when heated. The viscosity and thermal characteristics of mineral oil are poorer than water so temperature stability will not be as good. Mineral oil has very low electrical conductivity.

Warning

To prevent personal injury, use caution with mineral oil. Mineral oil is flammable and can cause serious injury if inhaled or ingested.

Silicone Oil (Dow Corning 200.05, 200.10, 200.20)

Some silicone oils offer a much wider operating temperature range than mineral oil. Like most oils, silicone oils have temperature control characteristics which are somewhat poorer than water. The viscosity changes significantly with temperature and thermal expansion occurs. These oils have very

high electrical resistivity. Silicone oils are safe and non-toxic but are expensive.

Fluid Characteristics Charts

Table 3 and Figure 5 help to select a heat exchange fluid media for your constant temperature bath. These charts are a visual and numerical representation of most of the physical qualities that are important to remember when you select a fluid. The list is not all inclusive. There are other useful fluids not shown in this list.

The charts include information on a variety of fluids which are often used as heat transfer fluid in baths. Because of the temperature range, some fluids may not be useful with your bath.

Table 3. Table of Various Bath Fluids

Fluid (# = Fluke Calibration Part No.)	Lower Temperature Limit *	Upper Temperature Limit *	Flash Point	Viscosity (centistokes)	Specific Gravity	Specific Heat (cal/g/°C)	Thermal Conductivity (cal/s/cm/°C)	Thermal Expansion (cm/cm/°C)	Resistivity (10 ¹² Ω-cm)
Halocarbon 0.8 #5019	-90 °C (v) **	70 °C (e)	NONE	5.7 @ -50 °C 0.8 @ 40 °C 0.5 @ 70 °C	1.71 @ 40 °C	0.2	0.0004	0.0011	-
Methanol	-96 °C (fr)	60 °C (b)	54 °C	1.3 @ -35 °C 0.66 @ 0 °C 0.45 @ 20 °C	0.810 @ 0 °C 0.792 @ 20 °C	0.6	0.0005 @ 20 °C	0.0014 @ 25 °C	-
Water	0 °C (fr)	95 °C (b)	NONE	1 @ 25 °C 0.4 @ 75 °C	1.00	1.00	0.0014	0.0002 @ 25 °C	-
Ethylene Glycol-50 % #5020	-35 °C (fr)	110 °C (b)	NONE	7 @ 0 °C 2 @ 50 °C 0.7 @ 100 °C	1.05	0.8 @ 0 °C	0.001	-	-
Mineral Oil	40 °C (v)	190 °C (fl)	190 °C	15 @ 75 °C 5 @ 25 °C	0.87 @ 25 °C 0.84 @ 75 °C 0.81 @ 125 °C	0.48 @ 25 °C 0.53 @ 75 °C 0.57 @ 125 °C	0.00025 @ 25 °C	0.0007 @ 50 °C	5 @ 25 °C
Dow Corning 200.05 Silicone Oil	-40 °C (v) **	133 °C (fl, cc)	133 °C	5 @ 25 °C	0.92 @ 25 °C	0.4	0.00028 @ 25 °C	0.00105	1000 @ 25 °C 10 @ 150 °C
Dow Corning 200.10 #5012	-35 °C (v) **	165 °C (fl, cc)	165 °C	10 @ 25 °C 3 @ 135 °C	0.934 @ 25 °C	0.43 @ 40 °C 0.45 @ 100 °C 0.482 @ 200 °C	0.00032 @ 25 °C	0.00108	1000 @ 25 °C 50 @ 150 °C
Dow Corning 200.20 #5013	7 °C (v)	230 °C (fl, cc)	230 °C	20 @ 25 °C	0.949 @ 25 °C	0.370 @ 40 °C 0.393 @ 100 °C 0.420 @ 200 °C	0.00034 @ 25 °C	0.00107	1000 @ 25 °C 50 @ 150 °C
Dow Corning 200.50 Silicone Oil	25 °C (v)	280 °C (fl, cc)	280 °C	50 @ 25 °C	0.96 @ 25 °C	0.4	0.00037 @ 25 °C	0.00104	100 @ 25 °C 1 @ 150 °C
Dow Corning 550 #5016	70 °C (v)	232 °C (fl, cc) 300 °C (fl, oc)	232 °C	50 @ 70 °C 10 @ 104 °C	1.07 @ 25 °C	0.358 @ 40 °C 0.386 @ 100 °C 0.433 @ 200 °C	0.00035 @ 25 °C	0.00075	100 @ 25 °C 1 @ 150 °C
Dow Corning 710 #5017	80 °C (v)	302 °C (fl, cc)	302 °C	50 @ 80 °C 10 @ 104 °C	1.11 @ 25 °C	0.363 @ 40 °C 0.454 @ 100 °C 0.505 @ 200 °C	0.00035 @ 25 °C	0.00077	100 @ 25 °C 1 @ 150 °C
Dow Corning 210-H Silicone Oil	66 °C (v)	315 °C (fl, oc)	315 °C	50 @ 66 °C 14 @ 204 °C	0.96 @ 25 °C	0.34 @ 100 °C	0.0003	0.00095	100 @ 25 °C 1 @ 150 °C
Heat Transfer Salt #5001	145 °C (fr)	530 °C	NONE	34 @ 150 °C 6.5 @ 300 °C 2.4 @ 500 °C	2.0 @ 150 °C 1.9 @ 300 °C 1.7 @ 500 °C	0.33	0.0014	0.00041	1.7 Ω/cm ³

*Limiting Factors – b-boiling point, e-high evaporation, fl- flash point, fr- freeze point, v-viscosity – Flash point test, oc=open cup, cc=closed cup
**Very-low water solubility, ice will form as a slush from condensation below freezing.

Limitations and Disclaimer

The information in this manual regarding fluids is only to be used as a general guide you choose a fluid. Though every effort has been made to provide correct information, we cannot guarantee accuracy of data or assure suitability of a fluid for a particular application. Specifications may change and sources sometimes offer differing information. Fluke Calibration is not liable for any personal injury or damage to equipment, product, or facilities that result from the use of these fluids. The user of the bath is responsible and must collect correct information, exercise proper judgment, and ensure safe operation. Do not operate near the limits of certain properties such as the flash point or viscosity as this can compromise safety or performance. Consider the safety policies of your company regarding flash points, toxicity, and such issues. You must read the MSDS (material safety data sheets) and act accordingly.

Figure 5. Chart of Various Bath Fluids

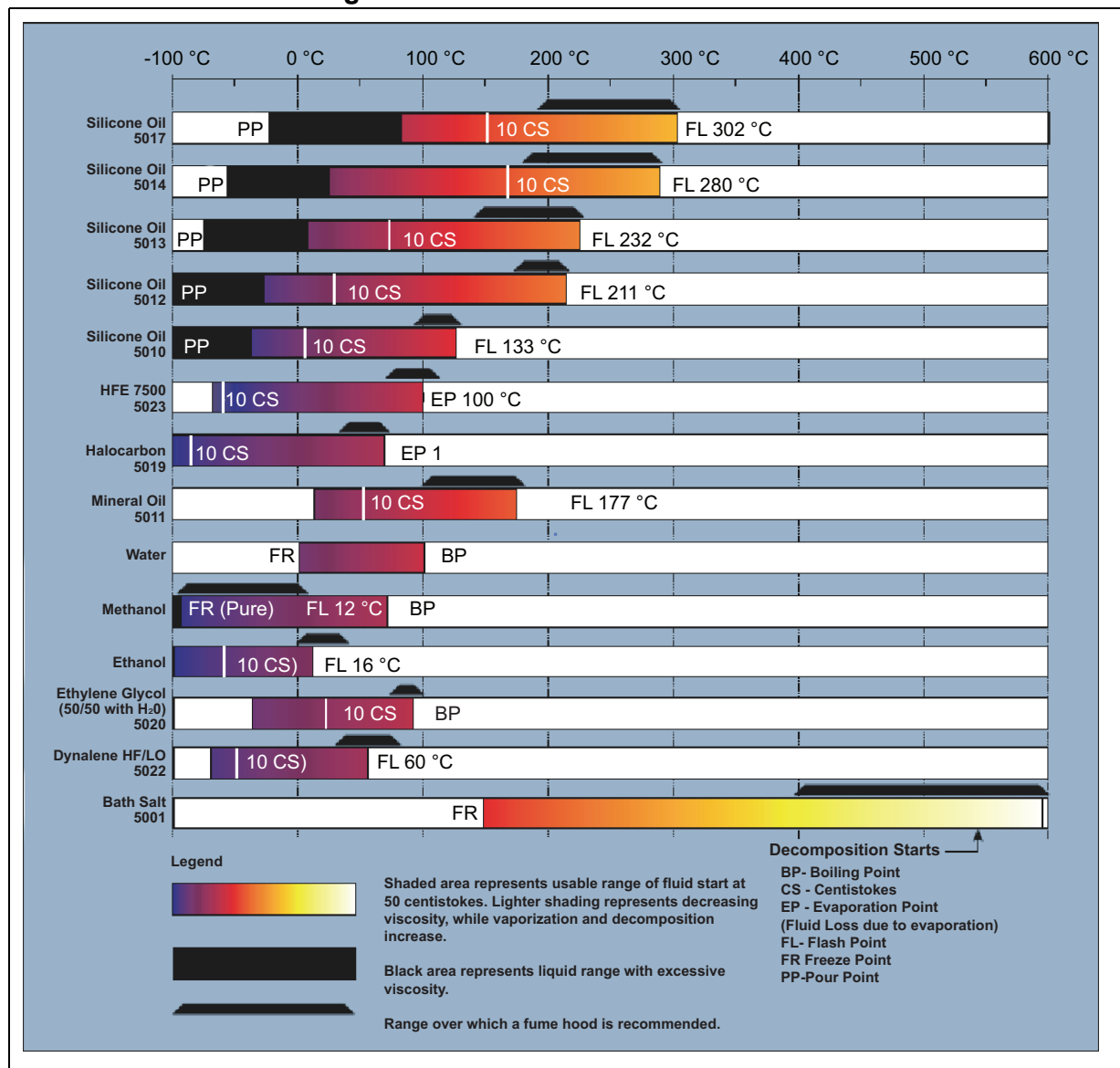

About the Graph

The fluid graph illustrates some of the important qualities of the fluids shown.

Temperature Range: The temperature scale in the graph is in degrees Celsius. The fluids' general range of application is indicated by the shaded bands. Qualities that include pour point, freeze point, important viscosity points, flash point, boiling point, and others may be shown.

Freezing Point: The freezing point of a fluid is an obvious limitation to stirring. As the fluid approaches the freezing point, high viscosity can also limit performance.

Pour Point: This represents a handling limit for the fluid.

Viscosity: Points shown are at 50 centistokes and 10 centistokes viscosity. When viscosity is greater than 50 centistokes stirring is poor and the fluid is unsatisfactory for bath applications. Optimum stirring generally occurs at 10 centistokes and below.

Fume Point: Use a fume hood. This point is subjective in nature and is impacted by individual tolerance to different fumes and smells, how well the bath is covered, the surface area of the fluid in the bath, the size and ventilation of the facility where the bath is located, and other conditions. It is assumed that the bath is well covered at this point. This is subject to company policy.

Flash Point: The point at which ignition can occur. The point shown can be either the open or closed cup flash point. Refer to the flash point discussion in [Bath Fluid](#).

Boiling Point: At or near the boiling point of the fluid, the temperature stability is difficult to maintain. Fuming or evaporation is excessive. Large amounts of heater power may be required because of the heat of vaporization.

Decomposition: The temperature can reach a point at which decomposition of the fluid begins. Further increasing the temperature can accelerate decomposition to the point of danger or impracticality.

Stirring

Stirring of the bath fluid is important for stable temperature control. The fluid must mix well for good temperature uniformity and fast controller response. The stirrer is adjusted for optimum performance. Table 4 shows nominal stirrer motor settings for several fluids.

If the stirrer does not function properly, the instrument oscillates and will not meet published specifications.

Note

If the bath is used with the probe basket removed, change the stir motor settings until a small vortex is seen in the liquid.

Warning

Do not mix water and oil when you exceed temperatures of 90 °C.

Table 4. Nominal Stirrer Motor Settings with Different Liquids

Liquid	Stir Motor Setting	Temperature
Distilled Water	15	5 °C to 90 °C (41 °F to 194 °F)
Ethylene Glycol	15	-5 °C to 90 °C (25 °F to 194 °F)
200.05 Oil	15	-5 °C to 125 °C (-23 °F to 258 °F)
200.10 Oil	15	25 °C to 125 °C (77 °F to 258 °F)

Fluid Drain

To drain the fluid from the Product, tightly screw the transport/pour access lid onto the top of the bath and pour the liquid into an appropriate container.

Temperature Controller

A Fluke Calibration unique hybrid digital/analog temperature controller controls the bath temperature. The controller offers the tight control stability of an analog temperature controller as well as the flexibility and programmability of a digital controller.

A platinum resistance sensor in the control probe monitors the bath temperature. The signal is electronically compared with the programmable reference signal, amplified, and then fed to a pulse-width modulator circuit which controls the amount of power applied to the bath heater.

Operate the bath within the temperature range given in [Specifications](#). For protection against solid-state relay failure or other circuit failure, a bi-metallic cut-out automatically turns off the heater any time the bath temperature exceeds the maximum temperature.

Use the controller to set the bath temperature with high resolution, adjust the proportional band, monitor the heater output power, and program the controller configuration and calibration parameters.

Controller Operation

This section discusses how to operate the bath temperature controller with the front control panel. Use the front panel to monitor the well temperature, set the temperature set-point in degrees C or F, monitor the heater output power, adjust the controller proportional band, and program the calibration parameters, operating parameters, and serial interface configuration. Operation of the functions and parameters are shown in the flowchart in [Figure 6](#). Copy this chart for reference.

Well Temperature

The display allows direct viewing of the actual well temperature. This temperature value is what is normally shown on the display. The temperature units are displayed at the right. For example,

100.00C Well temperature in degrees Celsius

Push **Exit** to access the temperature display function from any function.

Temperature Set-point

Set the temperature set-point to any value within the range and resolution as given in the specifications. Do not exceed the safe upper temperature limit of any device inserted into the well.

To set the temperature, select the set-point memory and adjust the set- point value.

Programmable Set-points

The controller stores eight set-point temperatures in memory. Quickly recall the set-points to conveniently set the calibrator to a previously-programmed temperature set-point.

To set the temperature, select the set-point memory first. Push **SET** to access this function from the temperature display function. The number of the current set-point memory shows at the left on the display followed by the current set-point value.

100.00C Well temperature in degrees Celsius

Push **SET** Access set-point memory

1 25. Set-point memory 1. 25 °C currently used

To change the set-point memory push **UP** or **DOWN**.

4 125. New set-point memory 4 125. °C

Push **SET** to accept the new selection and access the set-point value.

Set-point Value

To adjust the set-point after you select the set-point memory, push **SET**.

4 125. Set-point 4 value in °C

If the set-point value is correct, hold **EXIT** to show the well temperature. Push **UP** or **DOWN** to adjust the set-point value.

125.00 New set-point value

When the controller reaches the desired set-point value, push **SET** to accept the new value and to access the temperature scale units selection. If you push **EXIT** instead of **SET**, any changes made to the set-point are ignored.

Push **SET** Accept new set-point value

Figure 6. Controller Operation Flowchart

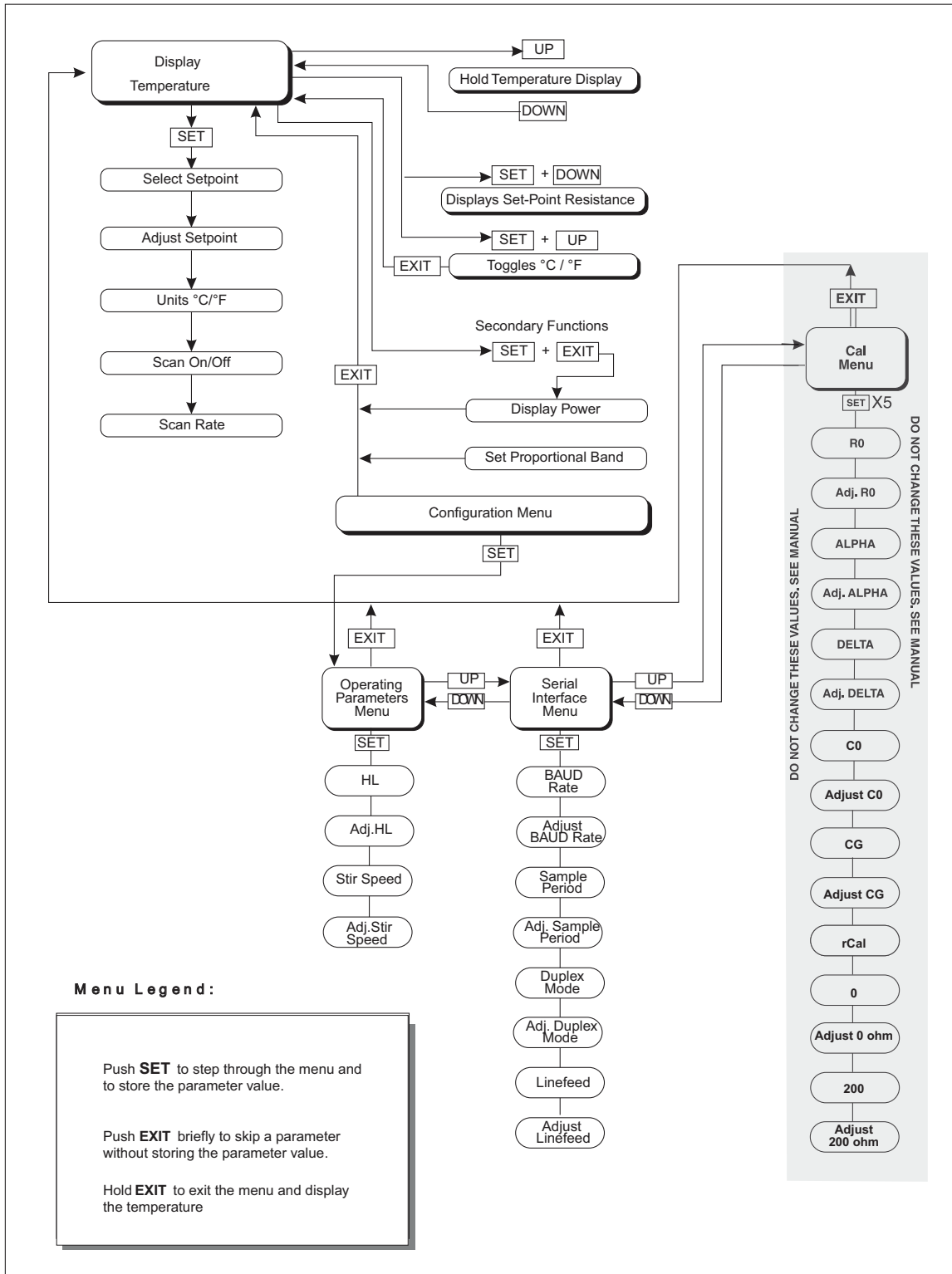

Temperature Scale Units

The selected units (Celsius (°C) or Fahrenheit (°F)) show in the displayed well temperature, set-point, and proportional band.

Push **SET** after you adjust the set-point value to change display units.

Un= C Scale units currently selected

Push **UP** or **DOWN** to change the units.

Un= F New units selected

Scan

Set and enable the scan rate so that when the set-point is changed the bath heats or cools at a specified rate (degrees per minute) until it reaches the new set-point. With the scan disabled the bath heats or cools at the maximum possible rate.

Scan Control

Control the scan with the scan on/off function that appears in the main menu after the set-point function.

Sc=OFF Scan function off

Push **UP** or **DOWN** to toggle the scan on or off.

Sc=On Scan function on

Push **SET** to accept the present setting and continue.

Scan Rate

The next function in the main menu is the scan rate. Set the scan rate from .1 °C/min to 99.9 °C/min. The maximum scan rate, however, is limited by the natural heating or cooling rate of the instrument. This is often <100 °C/min, especially when cooling.

The scan rate function appears in the main menu after the scan control function. The scan rate units are in degrees C per minute.

Sr= 10.0 Scan rate in °C/min

Push **UP** or **DOWN** to change the scan rate.

Sr= 2.0 New scan rate

Push **SET** to accept the new scan rate and continue.

Temperature Display Hold

The Product has a display hold function which allows an external switch to freeze the displayed temperature and stop the scan of the set-point. Use this function to test thermal switches and cut-outs. The instrument must be powered off before you attach thermal switches or cut-outs. This section explains the functions available that operate the temperature hold feature. An example of how to set up and use the hold feature to test a switch follows.

To enable the hold feature, push **UP** when the temperature displays. The hold temperature display shows the hold temperature on the right and the switch status on the left. For the status **c** means the switch is closed and **o** means the switch is open. In the active position of the switch, the status flashes (opposite the normal position). The hold temperature shows what the temperature of the well was when the switch changed from its normal position to its active position. While the switch is in the normal position, the hold temperature will follow the well temperature.

If the Scan Control is **OFF** and the hold temperature display is in use, the temperature at which the switch is activated **does not** affect the set-point temperature. However, if the scan control is **ON** and the hold temperature display is in use, the temperature at which the switch is activated is **stored** as the new set-point temperature.

Operation of the temperature hold display is outlined below.

143.50C Well temperature display

Push **UP** Access hold display

c 144.8 Switch status and hold temperature

Push **DOWN** to return to the normal well temperature display.

Mode Setting

The hold function is always in the automatic mode. In this mode the normal position is set to whatever the switch position is when the set-point is changed. For example, if the switch is currently open when the set-point is changed, the closed position then becomes the new active position. The normal position will be set automatically under any of these conditions:

- a new set-point number is selected
- the set-point value is changed
- a new set-point is set through the communications channels

Switch Wiring

The thermal switch or cut-out is wired to the calibrator at the two terminals on the back of the Product labeled **DISPLAY HOLD**. The switch wires can be connected to the terminals either way. Internally, the black terminal connects to ground. The red terminal connects to +5 V through a 100 k Ω resistor. The calibrator measures the voltage at the red terminal and interprets +5 V as open and 0 V as closed.

Switch Test Example

This section describes a possible application for the temperature hold feature and how the instrument is set up and operated.

Suppose you have a thermal switch which is supposed to open at about 75 °C (167 °F) and close at about 50 °C (122 °F) and you want to test the switch to see how accurate and repeatable it is. You can use the temperature hold feature and the scan function to test the switch. To make measurements, observe the display or, preferably, collect data with a computer connected to the RS-232 port.

To set up the test:

1. Connect the switch wires to the terminals on the back of the Product and place the switch in the well.
2. Enable set-point scanning by setting the scan to **ON** in the primary menu (see [Scan Control](#)).
3. Set the scan rate to a low value, say 1.0 °C/min. (see [Scan Rate](#)). If the scan rate is too high, you may lose accuracy because of transient temperature gradients. If the scan rate is too low, the duration of the test may be longer than is necessary. Experiment to find the best scan rate.
4. Set the first program set-point to a value above the expected upper switch temperature, for example, 90 °C (194 °F).
5. Set the second program set-point to a value below the expected lower switch temperature, for example, 40 °C (104 °F), in the program menu.
6. Collect data on a computer connected to the RS-232 port. Refer to [Serial Interface Parameters](#), for instructions to configure the RS-232 communications interface.

Secondary Menu

Access less-used functions with the secondary menu. To access the secondary menu, push **SET** and **EXIT** simultaneously, then release. The first function in the secondary menu is the heater power display. (See Figure 6.)

Thermal Electric Device (TED)

The temperature controller controls the temperature of the well by pulsing the TED on and off. The total power applied to the TED is determined by the duty cycle or the ratio of TED on time to the pulse cycle time. By knowing the amount of heating the user can tell if the calibrator is heating up to the set-point, cooling down, or controlling at a constant temperature. Monitor the percent heater power to know how stable the well temperature is. With good control stability the percent heating power should not fluctuate more than $\pm 5\%$ within 1 minute.

Access the heater power display in the secondary menu. Push **SET** and **EXIT** simultaneously and release. Heater power shows as a percentage of full power.

100.00C Well temperature

Push **SET** and **EXIT** Access heater power in secondary menu

SEC Flashes

12.0 P Heater power in percent

To exit out of the secondary menu, hold **EXIT**. To continue to the proportional band setting function, push **EXIT** momentarily or **SET**.

Proportional Band

In a proportional controller such as this, heater output power is proportional to the well temperature over a limited range of temperatures around the set-point. This range of temperature is called the proportional band. At the bottom of the proportional band the heater output is 100 %. At the top of the proportional band the heater output is 0. Thus, as the temperature rises, heater power is reduced, which consequently tends to lower the temperature. In this way, the temperature is maintained at a constant temperature.

The temperature stability of the well and response time depend on the width of the proportional band. If the band is too wide, the well temperature deviates excessively from the set-point due to varying external conditions. This is because the power output changes very little with temperature and the controller cannot respond well to changing conditions or noise in the system. If the proportional band is too narrow the temperature may swing back and forth because the controller overreacts to temperature variations. For best control stability, the proportional band must be set for the optimum width.

The proportional band width is set at the factory to about 5.0 °C. The proportional band width can be altered if the user desires to optimize the control characteristics for a particular application.

The proportional band width is easily adjusted from the front panel. Set the width to discrete values in degrees C or F, which depends on the selected units. The proportional band adjustment is accessed within the secondary menu. Push **SET** and **EXIT** to enter the secondary menu and show the heater power. Then push **SET** to access the proportional band.

Push **SET** and **EXIT** Access heater power in secondary menu

12.0 P Heater power in percent

Push **SET** Access proportional band

ProP Flashes ProP and the setting

5.0 Proportional band setting

To change the proportional band, push **UP** or **DOWN**.

4.0 New proportional band setting

To accept and store the new setting push **SET**. Push **EXIT** to continue without storing the new value.

Controller Configuration

The controller has several configuration and operating options and calibration parameters which are programmable through the front panel. To access these, push **SET** from the secondary menu after the proportional band. Push **SET** again to enter the first of three sets of configuration parameters: operating parameters, serial interface parameters, and calibration parameters. To select the menus, push **UP** and **DOWN** and then push **SET** (see Figure 6).

Operating Parameters

The operating parameters menu is indicated by,

PAr Operating parameters menu

The operating parameters menu contains the High Limit and Stir Speed parameters.

High Limit

The High Limit Parameter adjusts the upper set-point temperature. The factory default and maximum temperature are set to 126 °C (259 °F). For safety, adjust the HL down so the maximum temperature set-point is restricted.

HL High Limit parameter

Push **SET** to enable adjustment of HL

HL Flashes HL and displays the setting

H=126 Current HL setting

Adjust the HL parameter with **UP** or **DOWN**

H=90 New HL setting

Push **SET** to accept the new temperature limit.

Stir Speed

The Stir Speed parameter adjusts stirrer motor speed. The factory default is 20.

Str SP Flashes Str Sp and then displays the setting

0 Current stir speed setting

To change the stir speed, push **UP** or **DOWN**.

16 New stir speed setting

Push **SET** to accept the new stir speed.

The stir motor speed must be varied for best stability. Table 3 shows nominal settings for several fluids.

Serial Interface Parameters

The serial RS-232 interface parameters menu is indicated by,

SErIAL Serial RS-232 interface parameters menu

The serial interface parameters menu contains parameters which determine the operation of the serial interface. These controls only apply to instruments fitted with the serial interface. The parameters in the menu are: BAUD rate, sample period, duplex mode, and linefeed. Push **UP** to enter the menu.

BAUD Rate

The BAUD rate is the first parameter in the menu. The BAUD rate setting determines the serial communications transmission rate.

The BAUD rate parameter is indicated by,

bAUd Flashes bAUd and then displays the setting

2400 b Current BAUD rate

The BAUD rate of serial communications is programmable to 300 BAUD, 600 BAUD, 1200 BAUD, **2400 BAUD**, 4800 BAUD, or 9600 BAUD. Use **UP** or **DOWN** to change the BAUD rate value.

4800 b New BAUD rate

Push **SET** to set the BAUD rate to the new value or **EXIT** to abort the operation and skip to the next parameter in the menu.

Sample Period

The sample period is the next parameter in the serial interface parameter menu. The sample period is the time period in seconds between temperature measurements transmitted from the serial interface. If the sample rate is set to 5, the instrument transmits the current measurement over the serial interface approximately every 5 seconds. The automatic sampling is disabled with a sample period of 0. The sample period is indicated by,

SPer Flashes SPeR and then displays the setting

SP= 1 Current sample period (seconds)

Adjust the value with **UP** or **DOWN** and then use **SET** to store the sample rate to the displayed value. **EXIT** does not store the new value.

SP= 60 New sample period

Duplex Mode

The next parameter is the duplex mode. The duplex mode can be set to full duplex or half duplex. With full duplex, any commands received by the calibrator with the serial interface will be immediately echoed or transmitted back to the device of origin. With half duplex, the commands will be executed but not echoed. The duplex mode parameter is indicated by,

dUPL Flashes dUPL and then displays the setting

d=FULL Current duplex mode setting

The mode may be changed with **UP** or **DOWN** and **SET**.

d=HALF New duplex mode setting

Linefeed

The final parameter in the serial interface menu is the linefeed mode. This parameter enables (on) or disables (off) transmission of a linefeed character (LF, ASCII 10) after transmission of any carriage-return. The linefeed parameter is indicated by,

LF Flashes LF and then displays the setting

LF= On Current linefeed setting

The mode may be changed with **UP** or **DOWN** and **SET**.

LF= OFF New linefeed setting

Calibration Parameters

The controller gives access to a number of the bath calibration constants: R0, ALPHA, DELTA, C0, CG, and rCAL. These values are set at the factory and should not be altered. The correct values are important to the accuracy and proper and safe operation of the bath. Access to these parameters is available so that if the controller memory fails, the user may restore these values to the factory settings. Keep a list of these constants and their settings with the manual.

Caution

Do not change the values of the bath calibration constants from the factory-set values. The correct setting of these parameters is important to the safety and proper operation of the bath.

The calibration parameters menu is indicated by:

CAL Calibration parameters menu

Push **SET** five times to enter the menu.

The calibration parameters R0, ALPHA, DELTA, C0, CG, and rCAL characterize the resistance-temperature relationship of the platinum control sensor. These parameters may be adjusted by an experienced user to improve the accuracy of the calibrator.

R0

This probe parameter refers to the resistance of the control probe at 0 °C (32 °F). The value of this parameter is set at the factory for best instrument accuracy.

ALPHA

This probe parameter refers to the average sensitivity of the probe between 0 °C (32 °F) and 100 °C (212 °F). The value of this parameter is set at the factory for best instrument accuracy.

DELTA

This probe parameter characterizes the curvature of the resistance-temperature relationship of the sensor. The value of this parameter is set at the factory for best instrument accuracy.

C0 and CG

These parameters calibrate the accuracy of the bath set-point. These are programmed at the factory when the bath is calibrated. Do not alter the value of these parameters. If it is necessary to calibrate the bath for improved accuracy, then calibrate R0 and ALPHA according to the procedure in [Calibration](#).

rCAL

Do not adjust this parameter. It is for factory use only.

Digital Communication Interface

The calibrator can communicate with and can be controlled by other equipment through the digital serial interface. This allows the user to set the set-point temperature, monitor the temperature, and access any of the other controller functions, all with remote communications equipment. Communications commands are summarized in [Figure 7](#).

Figure 7. Serial Cable Wiring

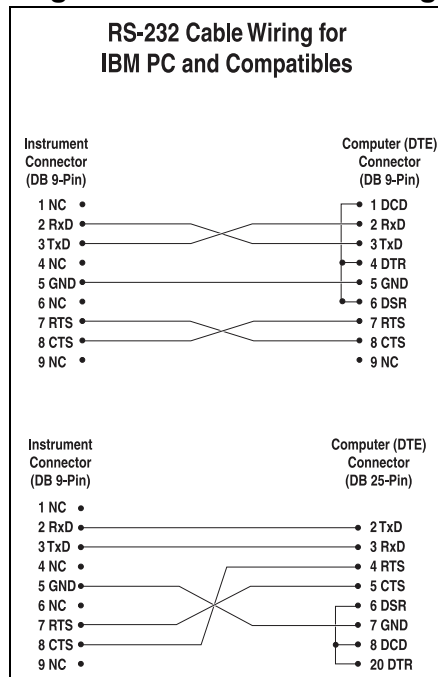

Serial Communications

The calibrator has an RS-232 serial interface that allows serial digital communications over fairly long distances. Use a serial interface to access any of the functions, parameters, and settings discussed in except for the BAUD rate setting.

Wiring

The serial communications cable attaches to the calibrator through the DB-9 connector at the back of the instrument. Figure 7 shows the pin-out of this connector and suggested cable wiring. To eliminate noise, the serial cable should be shielded with low resistance between the connector (DB-9) and the shield. If the unit is used in a heavy industrial setting, the serial cable length must be limited to **1 Meter**.

Setup

Before operation, first set up the serial interface by programming the BAUD rate and other configuration parameters. Program these parameters within the serial interface menu. The serial interface parameters menu is outlined in Figure 6. Refer to [Serial Interface Parameters](#) for BAUD Rate, Sample Period, Duplex Mode, and Linefeed.

To enter the serial parameter programming mode:

1. Push **EXIT** while you push **SET**, and then release to enter the secondary menu.
2. Push **SET** repeatedly until the display reads PAr.
3. Push **UP** until the serial interface menu is indicated with Serial.
4. Push **SET** to enter the serial parameter menu. The BAUD rate, the sample rate, the duplex mode, and the linefeed parameter are in the serial interface parameters menu.

Serial Operation

Once the cable has been attached and the interface set up properly, the controller immediately begins to transmit temperature readings at the programmed rate. Serial communications uses 8 data bits, one stop bit, and no parity. The set-point and other commands can be sent through the serial interface to set the temperature set-point and view or program the various parameters. The interface commands are discussed in [Interface Commands](#). All commands are ASCII character strings terminated with a carriage-return character (CR, ASCII 13).

Interface Commands

The various commands to access calibrator functions through the digital interface are listed in this section (see Table 5). These commands are used with the RS-232 serial interface. Terminate the commands with a carriage-return character. The interface makes no distinction between upper- and lower-case letters, hence either can be used. Commands can be abbreviated to the minimum number of letters which determines a unique command. A command may be used to either set a parameter or display a parameter depending on whether there is a value sent with the command following a = character. For example, **s** <CR > returns the current set-point and **s =150.0**<CR> sets the set-point to 150.0 degrees.

In the list of commands in Table 5, characters or data within brackets, [and], are optional for the command. A slash, /, denotes alternate characters or data. Numeric data, denoted by *n*, can be entered in decimal or exponential notation. Characters are shown in lower case although upper case may be used. Spaces may be added within command strings and will simply be ignored. Backspace (BS, ASCII 8) may be used to erase the previous character. A terminating CR is implied with all commands.

Table 5. Controller Communications Commands

Command Description	Command Format	Command Example	Returned	Returned Example	Acceptable Values
Display Temperature					
Read current set-point	s[etpoint]	s	set: 999.99 {C or F}	set: 150.00 C	-
Set current set-point to <i>n</i>	s[etpoint]= <i>n</i>	s=200.00	-	-	Instrument Range
Read temperature	t[emperature]	t	t: 999.99 {C or F}	t: 55.6 C	-
Read temperature units	u[nits]	u	u: x	u: C	-
Set temperature units:	u[nits]=c/f	-	-	-	C or F
Set temperature units to Celsius	u[nits]=c	u=c	-	-	-
Set temperature units to Fahrenheit	u[nits]=f	u=f	-	-	-
Read scan mode	sc[an]	sc	scan: {ON or OFF}	scan:ON	-
Set scan mode	sc[an]=on/off	sc=on	-	-	ON or OFF
Read scan rate	sr[ate]	sr	srat: 99.9 {C or F}/min	srat:12.4C/min	-
Set scan rate	sr[ate]= <i>n</i>	sr=1.1	-	-	.1 to 99.9
Read hold	ho[ld]	ho	hold: open/closed, 99.9 {C or F}	hold: open, 30.5 C	-
Secondary Menu					
Read proportional band setting	pr[opband]	pr	pb: 999.9	pb: 15.9	-
Set proportional band to <i>n</i>	pr[opband]= <i>n</i>	pr=8.83	-	-	Depends on Configuration
Read heater power (duty cycle)	po[wer]	po	po: 999.9	po: 1.0	-
Configuration Menu					
Operating Parameters Menu					
Read stirrer motor speed	mo[tor]	mo	mo: 99	mo: 15	-
Set stirrer motor speed to <i>n</i>	mo[tor]= <i>n</i>	mo=16	-	-	0 to 40
Read high limit	hl	hl	hl:999	hl:126	-
Set high limit	hl= <i>n</i>	hl=90	-	-	0 to 126
Serial Interface Menu					
Read serial sample setting	sa[mple]	sa	sa: 9	sa: 1	-
Set serial sampling setting to <i>n</i> seconds	sa[mple]= <i>n</i>	sa=0	-	-	0 to 999
Set serial duplex mode:	du[plex]=f[ull]/h[alf]	-	-	-	FULL or HALF
Set serial duplex mode to full	du[plex]=f[ull]	du=f	-	-	-
Set serial duplex mode to half	du[plex]=h[alf]	du=h	-	-	-
Set serial linefeed mode:	lf[eed]=on/of[f]	-	-	-	ON or OFF
Set serial linefeed mode to on	lf[eed]=on	lf=on	-	-	-
Set serial linefeed mode to off	lf[eed]=of[f]	lf=of	-	-	-

Table 5. Controller Communications Command (cont.)

Command Description	Command Format	Command Example	Returned	Returned Example	Acceptable Values
Calibration Menu					
Read R0 calibration parameter	r[0]	r	r0: 999.999	r0: 100.578	-
Set R0 calibration parameter to <i>n</i>	r[0]=n	r=100.324	-	-	90 to 110
Read ALPHA calibration parameter	al[pha]	al	al: 9.9999999	al: 0.0038573	-
Set ALPHA calibration parameter to <i>n</i>	al[pha]=n	al=0.0038433	-	-	.002 to 005
Read DELTA calibration parameter	de[ltā]	de	de:9.99999	de: 1.507	-
Read DELTA calibration parameter	de[ltā]=n	de=1.3742	-	-	0–3.0
Read C0 calibration parameter	*c[0]	*c	c0:99.9999	c0:-0.297	-
Set C0 calibration parameter	*c[0]=n	*c=-5.113	-	-	-
Read CG calibration parameter	*cg	*cg	cg:99.999	cg:-0.555	-
Set CG calibration parameter	*cg=n	*cg=-4.115	-	-	-
Functions not on menu					
Read firmware version number	*ver[sion]	*ver	ver.9999,9.99	ver.7102,2.00	-
Read structure of all commands	h[elp]	h	list of commands	-	-
Read all operating parameters	all	all	list of parameters	-	-
Legend:	[] Optional Command data {} Returns either information n Numeric data supplied by user 9 Numeric data returned to user x Character data returned to user				
Note:	When DUPLEX is set to FULL and a command is sent to READ, the command is returned followed by a carriage return and linefeed. Then the value is returned as indicated in the RETURNED column.				

Calibrate a Single Probe

Insert the probe to be calibrated into the well of the bath. For best results insert the probe to the full depth of the well. Once you insert the probe into the well, allow adequate stabilization time so the test probe temperature settles as described above. Once the probe has settled to the temperature of the well, compare that temperature to the displayed calibrator temperature. The display temperature should be stable to within 0.1 °C (32.18 °F) for best results.

Caution

Never introduce any foreign material into the well.

Stabilization and Accuracy

The stabilization time of the bath depends on the conditions and temperatures involved. Typically, the test well will be stable to 0.1 °C within 10 minutes of reaching the set-point temperature. Ultimate stability is achieved 30 minutes after the bath reaches the set temperature.

If you insert another cold probe into a well, this requires another period of stabilizing, depending on the magnitude of the disturbance and the required accuracy. For example, if you insert a .25-in diameter room temperature probe at 200 °C, it takes 5 minutes to be within 0.1 °C of its settled point and takes 10 minutes to achieve maximum stability.

To speed up the calibration process, know how soon to make the measurement. Make typical measurements at the desired temperatures with the test probes under test to establish these times.

Calibration

Note

Consider this procedure a general guideline. Each laboratory must write their own procedure based on their equipment and their quality program. Each procedure should be accompanied by an uncertainty analysis also based on the equipment and environment of the laboratory.

You may want to calibrate the bath to improve the temperature set-point accuracy. To adjust calibration, adjust the controller probe calibration constants R0, ALPHA, and DELTA so that the temperature of the bath as measured with a standard thermometer agrees more closely with the set-point. The thermometer used must be able to measure the well temperature with higher accuracy than the desired accuracy of the bath. Use a good thermometer and this calibration procedure and the bath can be calibrated to an accuracy of better than 0.5 °C up to 200 °C.

Calibration Points

When you calibrate the bath, adjust R0, ALPHA, and DELTA to minimize the set-point error at each of three different bath temperatures. Any three reasonably separated temperatures can be used for the calibration. Improved results can be obtained for shorter ranges when you use temperatures that are just within the most useful operating range of the Product. The farther apart the calibration temperatures, the larger will be the calibrated temperature range, but the calibration error will also be greater over the range. For instance, if you choose 50 °C to 150 °C as the calibration range, then the calibrator may achieve an accuracy of say ± 0.3 °C over the range 50 °C to 150 °C. Choosing a range of 50 °C to 90 °C may allow the calibrator to have a better accuracy of maybe ± 0.2 °C over that range, but outside that range the accuracy may be only ± 1.5 °C.

Calibration Procedure

Follow these steps for the calibration procedure:

1. Choose three set-points to use in the calibration of the R0, ALPHA, and DELTA parameters. These set-points are generally 2.5 °C, 45 °C, and 100.0 °C (36.5 °F, 113 °F, and 212 °F) but other set-points can be used.
2. Set the bath to the low set-point. When the bath reaches the set-point and the display is stable, wait about 15 minutes and then take a reading from the thermometer. Sample the set-point resistance by holding down **SET** and pushing **DOWN**. Write these values down as T₁ and R₁ respectively.
3. Repeat step 2 for the other two set-points and record them as T₂, R₂, T₃, and R₃ respectively.
4. Use the recorded data to calculate new values for R0, ALPHA, and DELTA parameters with the equations given below.

Compute DELTA

$$A = T_3 - T_2$$

$$B = T_2 - T_1$$

$$C = \left[\frac{T_3}{100} \right] \left[1 - \frac{T_3}{100} \right] - \left[\frac{T_2}{100} \right] \left[1 - \frac{T_2}{100} \right]$$

$$D = \left[\frac{T_2}{100} \right] \left[1 - \frac{T_2}{100} \right] - \left[\frac{T_1}{100} \right] \left[1 - \frac{T_1}{100} \right]$$

$$E = R_3 - R_2$$

$$F = R_2 - R_1$$

$$\text{delta} = \frac{AF - BE}{DE - CF}$$

T₁₋₃ – Measured temperature using thermometer.

R₁₋₃ – Value of R from display of product (push **SET** and **DOWN** simultaneously.)

where

T₁ and R₁ are the measured temperature and resistance at 2.5 °C

T₂ and R₂ are the measured temperature and resistance at 45.0 °C

T₃ and R₃ are the measured temperature and resistance at 100.0 °C

Compute R0 & ALPHA

$$a_1 = T_1 + \text{delta} \left[\frac{T_1}{100} \right] \left[1 - \frac{T_1}{100} \right]$$

$$a_3 = T_3 + \text{delta} \left[\frac{T_3}{100} \right] \left[1 - \frac{T_3}{100} \right]$$

$$rzero = \frac{R_3 a_1 - R_1 a_3}{a_1 - a_3}$$

$$\text{alpha} = \frac{R_1 - R_3}{R_3 a_1 - R_1 a_3}$$

Where:

delta is the new value of DELTA computed above

Program the new values for DELTA (delta), R0 (rzero), and ALPHA (alpha) into the Product with these steps.

1. Push **SET** and **EXIT** simultaneously and then push **UP** until CAL shows.
2. Push **SET** five times until R0 is displays.
3. Push **SET** then use **UP** or **DOWN** until the correct numerical setting shows.
4. Push **SET** to accept the new value.
5. Repeat step 2 for ALPHA and DELTA.

Accuracy and Repeatability

Check the accuracy of the Product at various points over the calibrated range. If the Product does not pass specification at all set-points, repeat the [Calibration Procedure](#).

Maintenance

- With proper care, the Product requires very little maintenance. Refer to [Safety Information](#).
- If the outside of the instrument becomes soiled, wipe it clean with a damp cloth and mild detergent. Do not use harsh chemicals on the surface which can damage the paint.
- Keep the well of the calibrator clean and clear of any foreign matter. Do not use chemicals to clean the well.
- Handle the Product with care. Avoid knocking or dropping the instrument.
- If a hazardous material is spilled on or inside the Product, take the appropriate decontamination steps as outlined by the national safety council with respect to the material.

- If the mains supply cord becomes damaged, replace it with a cord with the appropriate gauge wire for the current of the Product. If there are any questions, see [Service Information](#).
- Before the use of any cleaning or decontamination method except those recommended by Fluke Calibration, check with an Authorized Service Center to be sure that the proposed method does not damage the Product.

Troubleshooting Problems, Possible Causes, and Solutions

This section contains information on troubleshooting the Product.

If the Product functions abnormally, this section may help to find and solve the problem. Several possible problem conditions are described along with likely causes and solutions. Please read this section carefully and attempt to understand and solve the problem. If the problem cannot otherwise be solved, contact an Authorized Service Center (see [Service Information](#)). Be sure to have the model number and serial number of the Product available.

Problem	Possible Causes and Solutions
Incorrect temperature reading	<p>Incorrect R0, ALPHA, and DELTA parameters. Find the value for R0, ALPHA, and DELTA on the Report of Calibration that ships with the Product. Reprogram the parameters into the Product (see Calibration Parameters). Allow the Product to stabilize and verify the accuracy of the temperature reading.</p> <p>Controller locked up. The controller may have locked up due to a power surge or other aberration. Initialize the system by performing the Factory Reset Sequence.</p> <p>Factory Reset Sequence. Hold SET and EXIT simultaneously while powering up the Product. The Product shows ‘-init-’, the model number, and the firmware version. Each of the controller parameters and calibration constants must be reprogrammed. The values can be found in the Report of Calibration that shipped with the Product.</p>

Problem	Possible Causes and Solutions
The Product heats or cools too quickly or too slowly	<p>Incorrect scan and scan rate settings. The scan and scan rate settings may be set to unwanted values. Check the Scan and Scan Rate settings. The scan may be off (if the Product seems to be responding too quickly). The scan may be on with the Scan Rate set low (if unit seems to be responding too slowly).</p>
o shows at the left of the display	<p>External switch is open. The external switch is open which causes the displayed temperature to be frozen and keeps the set-point from scanning. Push DOWN to turn the switch test off.</p>
The display shows any error	<p>Controller problem. The error messages signify the following problems with the controller.</p> <ul style="list-style-type: none"> Err 1 – a RAM error Err 2 – a NVRAM error Err 3 – a Structure error Err 4 – an ADC setup error Err 5 – an ADC ready error Err 6 – Defective control sensor. The control sensor may be shorted, open, or otherwise damaged. <p>Do the Factory Reset Sequence described above to initialize the system.</p> <ul style="list-style-type: none"> Err 7 – Heater control error. Do the Factory Reset Sequence described above to initialize the system.
The stirrer is not stirring	<p>Stirrer speed needs adjusting. In the Operating Parameters menu, adjust the stirrer speed (Str Sp) to 0. Wait for the motor to stop. Adjust the stirrer speed to greater than 8 but less than or equal to 25.</p>

Problem	Possible Causes and Solutions
Temperature readout is not the actual temperature of the well	Possible RF energy emission. With the unit stable, slowly rotate the unit. If no change occurs, the unit may need to be calibrated. If the display changes more than twice the normal display deviation, another unit in the area could be emitting RF energy. Move the unit to a different location and rotate the unit again. If the temperature is correct in this new area or deviates differently than the first are, RF energy is present in the room. If you must perform the test in the affected area, use the comparison test to eliminate any possible errors.
Instrument is unstable	Varying line voltage or fluid is not stirring. Place the Product on a clean power line. If the fluid is not stirring, turn the Product off for 1 minute.
AC voltage present on the chassis	Use a wall plug tester to check the main power plug at the wall. Use an ohmmeter to check the continuity between the ground prong on the PEM and the chassis. If the resistance reading is greater than 3 Ω , there is a problem. Check the power cord for continuity on the ground prongs. If the resistance is greater than 1 Ω , replace the power cord.

