

Keysight B2900B/BL Series Precision Source/Measure Unit

Programming Guide



Notices

Copyright Notice

© Keysight Technologies 2020

No part of this manual may be reproduced in any form or by any means (including electronic storage and retrieval or translation into a foreign language) without prior agreement and written consent from Keysight Technologies as governed by United States and international copyright laws.

Manual Part Number

B2910-90120

Edition

Edition 1, December 2020

Published by:

Keysight Technologies Japan K.K.,
9-1, Takakura-cho, Hachioji-shi, Tokyo
192-8550 Japan

Technology Licenses

The hardware and/or software described in this document are furnished under a license and may be used or copied only in accordance with the terms of such license.

U.S. Government Rights

The Software is “commercial computer software,” as defined by Federal Acquisition Regulation (“FAR”) 2.101. Pursuant to FAR 12.212 and 27.405-3 and Department of Defense FAR Supplement (“DFARS”) 227.7202, the U.S. government acquires commercial computer software under the same terms by which the software is customarily provided to the public. Accordingly, Keysight provides the Software to U.S. government customers under its standard commercial license, which is embodied in its End User License Agreement (EULA), a copy of which can be found at <http://www.keysight.com/find/sweula>. The license set forth in the EULA represents the exclusive authority by which the U.S. government may use, modify, distribute, or disclose the Software. The EULA and the license set forth therein, does not require or permit, among other things, that Keysight: (1) Furnish technical information related to commercial

computer software or commercial computer software documentation that is not customarily provided to the public; or (2) Relinquish to, or otherwise provide, the government rights in excess of these rights customarily provided to the public to use, modify, reproduce, release, perform, display, or disclose commercial computer software or commercial computer software documentation. No additional government requirements beyond those set forth in the EULA shall apply, except to the extent that those terms, rights, or licenses are explicitly required from all providers of commercial computer software pursuant to the FAR and the DFARS and are set forth specifically in writing elsewhere in the EULA. Keysight shall be under no obligation to update, revise or otherwise modify the Software. With respect to any technical data as defined by FAR 2.101, pursuant to FAR 12.211 and 27.404.2 and DFARS 227.7102, the U.S. government acquires no greater than Limited Rights as defined in FAR 27.401 or DFAR 227.7103-5 (c), as applicable in any technical data.

Warranty

THE MATERIAL CONTAINED IN THIS DOCUMENT IS PROVIDED “AS IS,” AND IS SUBJECT TO BEING CHANGED, WITHOUT NOTICE, IN FUTURE EDITIONS. FURTHER, TO THE MAXIMUM EXTENT PERMITTED BY APPLICABLE LAW, KEYSIGHT DISCLAIMS ALL WARRANTIES, EITHER EXPRESS OR IMPLIED, WITH REGARD TO THIS MANUAL AND ANY INFORMATION CONTAINED HEREIN, INCLUDING BUT NOT LIMITED TO THE IMPLIED WARRANTIES OF MERCHANTABILITY AND FITNESS FOR A PARTICULAR PURPOSE. KEYSIGHT SHALL NOT BE LIABLE FOR ERRORS OR FOR INCIDENTAL OR CONSEQUENTIAL DAMAGES IN CONNECTION WITH THE FURNISHING, USE, OR PERFORMANCE OF THIS DOCUMENT OR OF ANY INFORMATION CONTAINED HEREIN. SHOULD KEYSIGHT AND THE USER HAVE A SEPARATE WRITTEN AGREEMENT WITH WARRANTY TERMS COVERING THE MATERIAL IN THIS DOCUMENT THAT CONFLICT WITH THESE

TERMS, THE WARRANTY TERMS IN THE SEPARATE AGREEMENT SHALL CONTROL.

Open Software License

A portion of the software in this product is licensed under terms of the General Public License Version 2 (“GPLv2”). The text of the license and source code can be found at:

www.keysight.com/find/GPLV2

Declaration of Conformity

Declarations of Conformity for this product and for other Keysight products may be downloaded from the Web. Go to www.keysight.com/go/conformity. You can then search by product number to find the latest Declaration of Conformity.

Latest Information

To get the latest firmware/software/electronic manuals/specifications/support information, go to www.keysight.com and type in the product number in the Search field at the top of the page.

In This Manual

This manual provides the information for controlling the Keysight Technologies B2900 by using an external computer, and consists of the following chapters.

1. "Controlling the Keysight B2900"

Describes how to control the B2900 on a task basis.

2. "Programming Examples"

Introduces example programs for controlling the B2900.

See *Keysight B2900B/BL Series User's Guide* for information about the B2900 itself.

Refer to *Keysight B2900B/BL Series SCPI Command Reference* for the SCPI messages and conventions, data output format, error code, and the details on Keysight B2900 SCPI commands.

Contents

1 Controlling the Keysight B2900

Before Starting	10
Software Requirements	10
Connecting to the Interface.	10
Starting the Instrument Control	10
Controlling Various Functions.	12
Setting the Power Frequency	12
Resetting to the Initial Settings.	13
Setting the Beeper.	13
Setting the Date and Time.	13
Performing the Self-Test	13
Performing the Self-Calibration	14
Setting the Operations at Power On	14
Reading an Error Message	14
Clearing the Error Buffer	14
Reading Timestamp	15
Clearing Timestamp	15
Setting the Automatic Clear of Timestamp.	15
Confirming the Firmware Revision	15
Setting the Remote Display Mode.	16
Making a Screen Dump	16
Performing a File Operation.	16
Controlling the Source Output	17
Enabling the Source Output	18
Setting the Source Output Mode	18
Applying the DC Voltage/Current	18
Stopping the Source Output	18
Setting the Limit (Compliance) Value	18
Setting the Output Range	19
Setting the Pulse Output.	19

Setting the Sweep Operation	20
Setting the Sweep Output	21
Setting the Ranging Mode of the Sweep Source	21
Setting the List Sweep Output	21
Setting the Source Output Trigger	22
Setting the Source Wait Time	23
Setting the Output Filter	23
Setting the Connection Type	24
Setting the Low Terminal State	24
Enabling or Disabling the High Capacitance Mode	24
Enabling or Disabling the Over Voltage/Current Protection	24
Specifying the Output-Off Status	24
Enabling or Disabling the Automatic Output-On Function	24
Enabling or Disabling the Automatic Output-Off Function	25
Controlling the Measurement Function	26
Enabling the Measurement Channel	26
Setting the Measurement Mode	26
Setting the Resistance Measurement Mode	27
Enabling or Disabling the Resistance Compensation	27
Performing Spot Measurement	27
Setting the Measurement Speed	27
Setting the Measurement Range	28
Setting the Measurement Auto Range Operation	28
Setting the Measurement Trigger	28
Setting the Measurement Wait Time	30
Performing Sweep Measurement	31
Stopping Measurement	31
Using the Math Function	32
Defining a Math Expression	32
Deleting an User Defined Math Expression	32
Enabling or Disabling the Math Function	32

Reading Math Result Data	32
Performing the Limit Test	34
Setting the Composite Limit Test	35
Setting Individual Limit Tests	35
Reading Limit Test Result	35
Using the Trace Buffer	36
Setting the Trace Buffer.	37
Reading the Trace Data.	37
Using Program Memory	38
Defining a Memory Program	38
Deleting a Program	38
Controlling the Program Operation.	38

2 Programming Examples

Preparations	43
To Create Your Project Template.	43
To Create Measurement Program	44
Spot Measurements	47
Pulsed Spot Measurements	50
Staircase Sweep Measurements	54
Pulsed Sweep Measurements	58
List Sweep Measurements	62
Pulsed List Sweep Measurements	66
Sampling Measurements	70
Pass/Fail Judgment and Math Function	74
Using Program Memory	78
Reading Binary Data	81

Performing MOSFET Id-Vd Measurements83

1 Controlling the Keysight B2900

- Before Starting 10
- Controlling Various Functions 12
- Controlling the Source Output 17
- Controlling the Measurement Function 26
- Using the Math Function 32
- Performing the Limit Test 34
- Using the Trace Buffer 36
- Using Program Memory 38

This chapter describes basic information to control the Keysight B2900.

Table 1-1

Conventions used in this document for expressing SCPI commands

Convention	Description
Angle brackets < >	Items within angle brackets are parameter abbreviations. For example, <NR1> indicates a specific form of numerical data.
Vertical bar	Vertical bars separate alternative parameters. For example, <VOLT CURR> indicates that either VOLT or CURR must be placed there.
Square brackets []	Items within square brackets are optional. The representation [SOURce:]VOLTage means that SOURce: may be omitted.
Parentheses ()	Items within parentheses are used in place of the usual parameter types to specify a channel list. The notation (@1:3) specifies a channel list that includes channels 1, 2, and 3. The notation (@1,3) specifies a channel list that includes only channels 1 and 3.
Braces { }	Braces indicate parameters that may be repeated zero or more times. It is used especially for representing arrays. The notation <A>{} shows that parameter “A” must be entered, while parameter “B” omitted or may be entered one or more times.

Before Starting

This section describes the information needed before starting programming.

- “Software Requirements”
- “Connecting to the Interface”
- “Starting the Instrument Control”

Software Requirements

Programming examples described in this manual use the following software. Install the software to your computer to execute the programming examples.

- Keysight IO Libraries Suite software
- Microsoft Visual Basic .NET software

Connecting to the Interface

Keysight B2900 supports GPIB, LAN, and USB interfaces. All three interfaces are live at power-on. Select the interface used for controlling the B2900. Connect your interface cable to the appropriate interface connector.

For the information on configuring the interfaces, see *Keysight B2900B/BL Series User's Guide*.

Starting the Instrument Control

The following program code is one of the simple program template for starting and ending the communication between the computer and the instrument. For using the code, the instrument address must be set to the `address` variable correctly.

```
Sub Main()  
    Dim rm As Ivi.Visa.Interop.ResourceManager  
    Dim ioObj As Ivi.Visa.Interop.FormattedIO488  
    Dim address As String = "enter address of your instrument"  
  
    rm = New Ivi.Visa.Interop.ResourceManager  
    ioObj = New Ivi.Visa.Interop.FormattedIO488  
    ioObj.IO = rm.Open(address)  
        insert your code for instrument control  
    ioObj.IO.Close()  
End Sub
```

The **address** value depends on the interface as shown below.

- For using the GPIB interface

The **address** value is the VISA GPIB Connect String displayed on the GPIB Configuration dialog box opened by pressing the More > I/O > GPIB function keys.

Example:

```
address = "GPIB0::23::INSTR"
```

- For using the USB interface

The **address** value is the VISA USB Connect String displayed on the USB Status dialog box opened by pressing the More > I/O > USB function keys.

Example:

```
address = "USB0::10893::12345::XY00001234::0::INSTR"
```

- For using the LAN interface

The **address** value is as follows.

```
address = "TCPIP0::xxx.yyy.zzz.aaa::5025::SOCKET"
```

Where, *xxx.yyy.zzz.aaa* is the IP Address displayed on the LAN Configuration dialog box opened by pressing the More > I/O > LAN > Config function keys.

Example:

```
address = "TCPIP0::192.168.0.1::5025::SOCKET"
```

Controlling Various Functions

This section describes how to control various functions apart from the source output and measurement functions.

- “Setting the Power Frequency”
- “Resetting to the Initial Settings”
- “Setting the Beeper”
- “Setting the Date and Time”
- “Performing the Self-Test”
- “Performing the Self-Calibration”
- “Setting the Operations at Power On”
- “Reading an Error Message”
- “Clearing the Error Buffer”
- “Reading Timestamp”
- “Clearing Timestamp”
- “Setting the Automatic Clear of Timestamp”
- “Confirming the Firmware Revision”
- “Setting the Remote Display Mode”
- “Making a Screen Dump”
- “Performing a File Operation”

Setting the Power Frequency

Power line frequency is set by the `:SYST:LFR` command.

Example `ioObj.WriteString(":SYST:LFR 50") '50 Hz`
`ioObj.WriteString(":SYST:LFR 60") '60 Hz`

Resetting to the Initial Settings

The initial settings are applied by the *RST command

Example `ioObj.WriteString("*RST")`

For the initial settings, see *SCPI Command Reference*.

Setting the Beeper

Beeper is enabled or disabled by the :SYST:BEEP:STAT command. And a beep sound of the specified frequency and duration is generated by the :SYST:BEEP command.

Example `ioObj.WriteString(":SYST:BEEP:STAT ON")` 'Enables beep
`ioObj.WriteString(":SYST:BEEP 200,1")` '200 Hz, 1 s

Setting the Date and Time

Date is set by the :SYST:DATE command. And time is set by the :SYST:TIME command.

Example `ioObj.WriteString(":SYST:DATE 2011,1,1")` 'Y,M,D
`ioObj.WriteString(":SYST:TIME 23,59,59")` 'H,M,S

Performing the Self-Test

Self-test is performed by the *TST? command. The *TST? command also returns the execution result. Before performing the self-test, disconnect test leads and cables from the channel terminals.

Example `ioObj.WriteString("*TST?")`
`Dim d As String = ioObj.ReadString()`
`If d = 0 Then`
 `Console.WriteLine("PASS")`
`Else`
 `Console.WriteLine("FAIL")`
`End If`

This example performs the self-test, and displays the test result, pass or fail.

Performing the Self-Calibration

Self-calibration is performed by the `*CAL?` command. The `*CAL?` command also returns the execution result. Before performing the self-calibration, disconnect test leads and cables from the channel terminals.

Example

```
ioObj.WriteString("*CAL?")
Dim d As String = ioObj.ReadString()
If d = 0 Then
    Console.WriteLine("PASS")
Else
    Console.WriteLine("FAIL")
End If
```

This example performs the self-calibration, and displays the result, pass or fail.

Setting the Operations at Power On

Operations at power-on are decided by the memory program specified by the `:PROG:PON:COPY` command. And the power-on program execution is enabled/disabled by the `:PROG:PON:RUN` command. The specified program must be previously defined in the program memory.

Example

```
ioObj.WriteString(":PROG:PON:COPY ""program1""")
ioObj.WriteString(":PROG:PON:RUN ON")
```

This example sets *program1* to the power-on program and enables the function.

Reading an Error Message

Error message is read one by one by using the `:SYST:ERR?` command. This command reads and removes the top item in the error buffer, and returns the code and message.

Example

```
ioObj.WriteString(":SYST:ERR?")
Dim d As String = ioObj.ReadString()
Console.WriteLine(d)
```

If the error buffer is empty, the response is `+0,"No error"`.

Clearing the Error Buffer

Error buffer is cleared by the `:SYST:ERR:ALL?` command. This command reads and returns all items in the error buffer, and clears the buffer.

Example

```
ioObj.WriteString(":SYST:ERR:ALL?")  
Dim d As String = ioObj.ReadString()  
Console.WriteLine(d)
```

If the error buffer is empty, the response is +0, "No error".

Reading Timestamp

Timestamp is read by the :SYST:TIME:TIM:COUN? command.

Example

```
ioObj.WriteString(":SYST:TIME:TIM:COUN?")  
Dim d As String = ioObj.ReadString()  
Console.WriteLine(d)
```

Clearing Timestamp

Timestamp is cleared by the :SYST:TIME:TIM:COUN:RES command.

Example

```
ioObj.WriteString(":SYST:TIME:TIM:COUN:RES")
```

Setting the Automatic Clear of Timestamp

Automatic clear of timestamp is enabled/disabled by the :SYST:TIME:TIM:COUN:RES:AUTO command. If this function is enabled, the timestamp is cleared when the initiate action occurs.

Example

```
ioObj.WriteString(":SYST:TIME:TIM:COUN:RES:AUTO ON")
```

Confirming the Firmware Revision

Instrument's (mainframe) identification and firmware revision are read by the *IDN? command.

Example

```
ioObj.WriteString("*IDN?")  
Dim d As String = ioObj.ReadString()  
Console.WriteLine(d)
```

The returned value will be as follows.

Keysight Technologies,model,serial,revision

model: mainframe model number

serial: mainframe serial number

revision: firmware revision number

Setting the Remote Display Mode

Front panel display under remote operation is enabled or disabled by the :DISP:ENAB command.

Example `ioObj.WriteString(":DISP:ENAB ON")`

Making a Screen Dump

Screen dump of the front panel display is made by the :HCOP:SDUM commands.

Example

```
ioObj.WriteString(":DISP:ENAB ON")
ioObj.WriteString(":DISP:VIEW GRAP")
ioObj.WriteString(":HCOP:SDUM:FORM JPG")
ioObj.WriteString("*OPC?") : s = ioObj.ReadString()
ioObj.WriteString(":HCOP:SDUM:DATA?")

Dim data As Object
data = ioObj.ReadIEEEBlock(Ivi.Visa.Interop.IEEEBinaryType.BinaryType_UI1,
False, True)

Dim dataSize As Integer = data.Length
Dim dumpname As String = "C:/temp/screendump1.jpg"
Using stream As New FileStream(dumpname, FileMode.Create, FileAccess.Write)
    stream.Write(data, 0, dataSize)
End Using
```

Performing a File Operation

File operation is effective for the USB memory connected to the front panel USB connector, and performed by the :MMEM commands. Error occurs if an USB memory is not connected.

Example

```
ioObj.WriteString(":MMEM:CAT?") 'Gets file catalog
s = ioObj.ReadString()

ioObj.WriteString(":MMEM:STOR:DATA ""test.dat""") 'Saves data
ioObj.WriteString("*OPC?") : s = ioObj.ReadString()

ioObj.WriteString(":MMEM:STOR:STAT ""test.sta""") 'Saves status
ioObj.WriteString("*OPC?") : s = ioObj.ReadString()

ioObj.WriteString(":MMEM:LOAD:STAT ""test.sta""") 'Loads status
```

Controlling the Source Output

This section describes how to control the source output of Keysight B2900.

- “Enabling the Source Output”
- “Setting the Source Output Mode”
- “Applying the DC Voltage/Current”
- “Stopping the Source Output”
- “Setting the Limit (Compliance) Value”
- “Setting the Output Range”
- “Setting the Pulse Output”
- “Setting the Sweep Operation”
- “Setting the Sweep Output”
- “Setting the Ranging Mode of the Sweep Source”
- “Setting the List Sweep Output”
- “Setting the Source Output Trigger”
- “Setting the Source Wait Time”
- “Setting the Output Filter”
- “Setting the Connection Type”
- “Setting the Low Terminal State”
- “Enabling or Disabling the High Capacitance Mode”
- “Enabling or Disabling the Over Voltage/Current Protection”
- “Specifying the Output-Off Status”
- “Enabling or Disabling the Automatic Output-On Function”
- “Enabling or Disabling the Automatic Output-Off Function”

NOTE

The string :SOUR in the command string described in this manual can be omitted. For example, :SOUR:VOLT can be :VOLT.

Enabling the Source Output

Source output is enabled by the :OUTP ON command.

Example `ioObj.WriteString(":OUTP ON")`

Setting the Source Output Mode

Source output mode is set by the :SOUR:FUNC:MODE command.

Example `ioObj.WriteString(":SOUR:FUNC:MODE CURR")` 'Current output
`ioObj.WriteString(":SOUR:FUNC:MODE VOLT")` 'Voltage output

Applying the DC Voltage/Current

DC current/voltage is immediately applied by the :SOUR:<CURR|VOLT> command during the source output is enabled.

If you want to control the DC current/voltage output timing using a trigger, use the :SOUR:<CURR|VOLT>:TRIG command. See [Figure 1-2](#).

Example `ioObj.WriteString(":SOUR:FUNC:MODE CURR")`
`ioObj.WriteString(":SOUR:CURR 1E-3")` 'Outputs 1 mA immediately
`ioObj.WriteString(":SOUR:FUNC:TRIG:CONT 1")`
`ioObj.WriteString(":SOUR:FUNC:MODE VOLT")`
`ioObj.WriteString(":SOUR:VOLT:MODE FIX")`
`ioObj.WriteString(":SOUR:VOLT:TRIG 1")` 'Outputs 1 V by a trigger

Stopping the Source Output

Source output is stopped and disabled by the :OUTP OFF command.

Example `ioObj.WriteString(":OUTP OFF")`

Setting the Limit (Compliance) Value

Limit (compliance) is set by the :SENS:<CURR|VOLT>:PROT command.

Example `ioObj.WriteString(":SENS:CURR:PROT 0.1")` '100 mA compliance
`ioObj.WriteString(":SENS:VOLT:PROT 10")` '10 V compliance

NOTE

To set the positive limit and the negative limit individually

Use the `:SENS:<CURR|VOLT>:PROT:POS` command to set the positive limit and the `:SENS:<CURR|VOLT>:PROT:NEG` command to set the negative limit. Do not use the `:SENS:<CURR|VOLT>:PROT` command.

Setting the Output Range

Output range is set by the `:SOUR:<CURR|VOLT>:RANG` command. And the auto range operation is enabled/disabled by the `:SOUR:<CURR|VOLT>:RANG:AUTO` command. The lower limit for the auto range operation is set by the `:SOUR:<CURR|VOLT>:RANG:AUTO:LLIM` command.

Example `ioObj.WriteString(":SOUR:VOLT:RANG:AUTO OFF")`
`ioObj.WriteString(":SOUR:VOLT:RANG 20")` '20 V range fix

`ioObj.WriteString(":SOUR:VOLT:RANG:AUTO ON")`
`ioObj.WriteString(":SOUR:VOLT:RANG:AUTO:LLIM 2")` '2 V range limit

Setting the Pulse Output

Pulse output is set by the `:SOUR:FUNC:SHAP PULS`, `:SOUR:PULS:DEL`, and `:SOUR:PULS:WIDT` commands. See [Figure 1-2](#). Pulse output is not available for B2901BL and B2910BL.

Pulse base and peak values are set by the `:SOUR:<CURR|VOLT>` command and the `:SOUR:<CURR|VOLT>:TRIG` command respectively.

Example `ioObj.WriteString(":SOUR:FUNC:SHAP PULS")`
`ioObj.WriteString(":SOUR:PULS:DEL 1E-3")` 'Delay time 1 ms
`ioObj.WriteString(":SOUR:PULS:WIDT 1E-3")` 'Pulse width 1 ms
`ioObj.WriteString(":SOUR:VOLT 0")` 'Base 0 V
`ioObj.WriteString(":SOUR:VOLT:TRIG 1")` 'Peak 1 V

NOTE

Outputting the pulse voltage/current

Execute the `:OUTP ON` command to start outputting the pulse base value.

Execute the `:INIT` to perform the specified pulse output and measurement.

Setting the Sweep Operation

For the variety of sweep output operation, see [Figure 1-1](#).

Sweep direction, upward or downward is set by the `:SOUR:SWE:DIR` command.

Sweep mode, single or double is set by the `:SOUR:SWE:STA` command.

Sweep spacing, linear or log is set by the `:SOUR:SWE:SPAC` command.

Example

```
ioObj.WriteString(":SOUR:SWE:DIR DOWN")  
ioObj.WriteString(":SOUR:SWE:STA DOUB")  
ioObj.WriteString(":SOUR:SWE:SPAC LOG")
```

Figure 1-1 Variety of Sweep Outputs

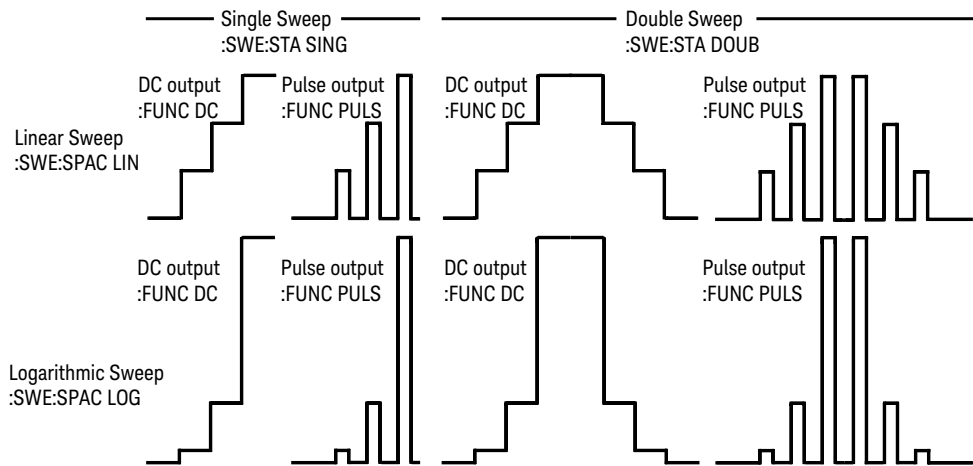

Setting the Sweep Output

Staircase sweep output is set by the `:SOUR:<CURR|VOLT>:MODE SWE` command, the `:SOUR:<CURR|VOLT>:<POIN|STEP>` or `:SOUR:SWE:POIN` command, and the `:SOUR:<CURR|VOLT>:<STAR|STOP>` or `:SOUR:<CURR|VOLT>:<CENT|SPAN>` command. See [Figure 1-3](#).

Before performing the pulsed sweep output, it is necessary to set the staircase sweep output and pulse output. For details on setting the pulse output, see [“Setting the Pulse Output” on page 19](#). Also see [Figure 1-4](#).

Example

```
ioObj.WriteString(":SOUR:VOLT:MODE SWE")
ioObj.WriteString(":SOUR:VOLT:STAR 0") 'Start 0 V
ioObj.WriteString(":SOUR:VOLT:STOP 1") 'Stop 1 V
ioObj.WriteString(":SOUR:VOLT:POIN 11") '11 points
```

NOTE

Outputting the sweep voltage/current

Execute the `:OUTP ON` command to start outputting the value set by the `:SOUR:<CURR|VOLT>` command.

Execute the `:INIT` to perform the specified sweep output and measurement.

Setting the Ranging Mode of the Sweep Source

Ranging mode of sweep source is set by the `:SOUR:SWE:RANG` command.

Example

```
ioObj.WriteString(":SOUR:SWE:RANG BEST") 'Covers all LIN steps
ioObj.WriteString(":SOUR:SWE:RANG FIX") 'Not change
ioObj.WriteString(":SOUR:SWE:RANG AUTO") 'Auto for each step
```

Setting the List Sweep Output

List sweep output is set by the `:SOUR:<CURR|VOLT>:MODE LIST` command and the `:SOUR:LIST:<CURR|VOLT>` command

Example

```
ioObj.WriteString(":SOUR:VOLT:MODE LIST")
ioObj.WriteString(":SOUR:LIST:VOLT 0,2,4,6,8,10,0")
```

NOTE

Outputting the list sweep voltage/current

Execute the :OUTP ON command to start outputting the value set by the :SOUR:<CURR|VOLT> command.

Execute the :INIT to perform the specified list sweep output and measurement.

Setting the Source Output Trigger

Source output trigger is simply set by the :TRIG<:TRAN | [:ALL]>:SOUR, :TRIG<:TRAN | [:ALL]>:TIM, :TRIG<:TRAN | [:ALL]>:COUN, and :TRIG<:TRAN | [:ALL]>:DEL commands. See [Figure 1-2](#).

Example

```
ioObj.WriteString(":TRIG:SOUR TIM")
ioObj.WriteString(":TRIG:TIM 4E-3")           'Interval 4 ms
ioObj.WriteString(":TRIG:COUN 11")          '11 points
ioObj.WriteString(":TRIG:TRAN:DEL 1E-3")    'Source delay 1 ms
```

Figure 1-2

To Perform DC and Pulse Output and Spot Measurement

Constant source :FUNC DC, :CURR:MODE FIX or :VOLT:MODE FIX

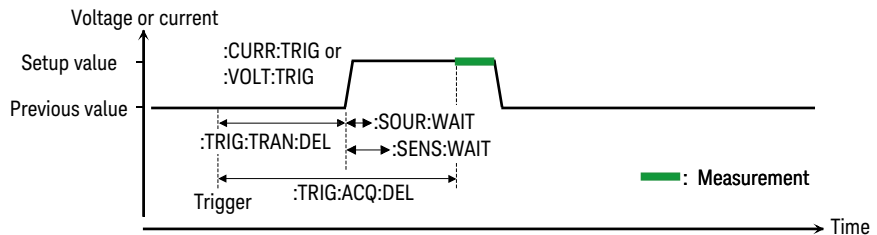

Pulse source :FUNC PULS, :CURR:MODE FIX or :VOLT:MODE FIX

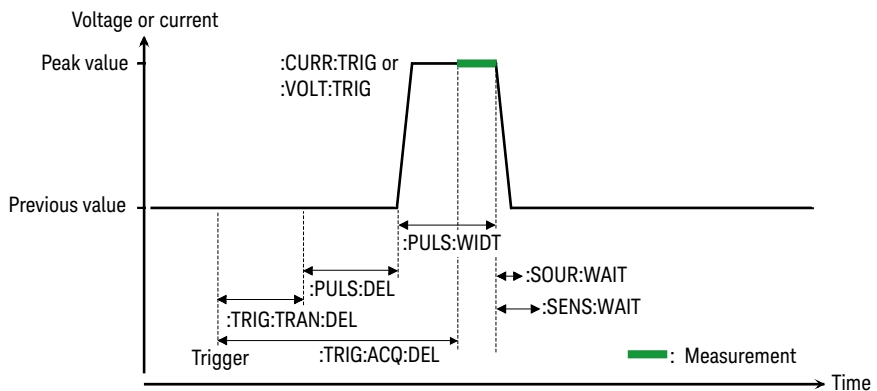

NOTE

If you want to use arm trigger, use the `:ARM<:TRAN | [:ALL]>:SOUR`, `:ARM<:TRAN | [:ALL]>:TIM`, `:ARM<:TRAN | [:ALL]>:COUN`, and `:ARM<:TRAN | [:ALL]>:DEL` commands. For more details, see *SCPI Command Reference*.

NOTE

If source channels are set as shown below, the source output starts simultaneously.

- Trigger source is set to the same mode.
- Delay time is set to the same value.
- Source output ranging mode is set to the fixed mode.
- Source wait time control is set to OFF.
- Measurement wait time control is set to OFF.
- Measurement ranging mode is set to the fixed mode.

Setting the Source Wait Time

Source wait time is set by the `:SOUR:WAIT` commands. See [Figures 1-3](#) and [1-4](#) for the wait time.

```
Example  ioObj.WriteString(":SOUR:WAIT OFF")           'Wait = 0 s
         ioObj.WriteString(":SOUR:WAIT ON")
         ioObj.WriteString(":SOUR:WAIT:AUTO OFF")
         ioObj.WriteString(":SOUR:WAIT:OFFS 10E-3") 'Wait = 10 ms
         ioObj.WriteString(":SOUR:WAIT ON")
         ioObj.WriteString(":SOUR:WAIT:AUTO ON")
         ioObj.WriteString(":SOUR:WAIT:OFFS 10E-3")
         ioObj.WriteString(":SOUR:WAIT:GAIN 1") 'Wait = 10 ms + initial wait
```

Setting the Output Filter

Output filter is set by the `:OUTP:FILT` command, the `:OUTP:FILT:AUTO` command, and the `:OUTP:FILT:<FREQ|TCON>` command.

```
Example  ioObj.WriteString(":OUTP:FILT ON")
         ioObj.WriteString(":OUTP:FILT:AUTO OFF")
         ioObj.WriteString(":OUTP:FILT:FREQ 10E+3") '10 kHz
```

Setting the Connection Type

Connection type, 2-wire or 4-wire is set by the :SENS:REM command.

Example `ioObj.WriteString(":SENS:REM ON")` '4-wire

Setting the Low Terminal State

Low terminal state, ground or floating is set by the :OUTP:LOW command.

Example `ioObj.WriteString(":OUTP OFF")`
`ioObj.WriteString(":OUTP:LOW GRO")` 'Ground
`ioObj.WriteString(":OUTP ON")`

Enabling or Disabling the High Capacitance Mode

High capacitance mode is set by the :OUTP:HCAP command.

Example `ioObj.WriteString(":OUTP:HCAP ON")`

Enabling or Disabling the Over Voltage/Current Protection

Over voltage/current protection is set by the :OUTP:PROT command.

Example `ioObj.WriteString(":OUTP:PROT ON")`

Specifying the Output-Off Status

Output-off status is set by the :OUTP:OFF:MODE command.

Example `ioObj.WriteString(":OUTP:OFF:MODE ZERO")` 'Zero volt
`ioObj.WriteString(":OUTP:OFF:MODE HIZ")` 'High impedance
`ioObj.WriteString(":OUTP:OFF:MODE NORM")` 'Normal

Enabling or Disabling the Automatic Output-On Function

Automatic output-on function is set by the :OUTP:ON:AUTO command.

Example `ioObj.WriteString(":OUTP:ON:AUTO ON")`

Enabling or Disabling the Automatic Output-Off Function

Automatic output-off function is set by the `:OUTP:OFF:AUTO` command.

Example `ioObj.WriteString(":OUTP:OFF:AUTO ON")`

Controlling the Measurement Function

This section describes how to control the measurement function of Keysight B2900.

- “Enabling the Measurement Channel”
- “Setting the Measurement Mode”
- “Setting the Resistance Measurement Mode”
- “Enabling or Disabling the Resistance Compensation”
- “Performing Spot Measurement”
- “Setting the Measurement Speed”
- “Setting the Measurement Range”
- “Setting the Measurement Auto Range Operation”
- “Setting the Measurement Trigger”
- “Setting the Measurement Wait Time”
- “Performing Sweep Measurement”
- “Stopping Measurement”

Enabling the Measurement Channel

Measurement channel is enabled by the `:OUTP ON` command.

Example `ioObj.WriteString(":OUTP ON")`

Setting the Measurement Mode

Measurement mode is set by the `:SENS:FUNC` commands.

Example

```
ioObj.WriteString(":SENS:FUNC:ALL")
ioObj.WriteString(":SENS:FUNC:OFF ""RES""")

ioObj.WriteString(":SENS:FUNC:OFF:ALL")
ioObj.WriteString(":SENS:FUNC ""RES""")
```

Setting the Resistance Measurement Mode

Resistance measurement mode, manual or auto is set by the `:SENS:RES:MODE` command.

Example `ioObj.WriteString(":SENS:RES:MODE AUTO")` 'Auto mode
`ioObj.WriteString(":SENS:RES:MODE MAN")` 'Manual mode

Enabling or Disabling the Resistance Compensation

Resistance compensation is set by the `:SENS:RES:OCOM` command.

Example `ioObj.WriteString(":SENS:RES:OCOM ON")` 'Enables compensation

Performing Spot Measurement

Spot measurement is performed by the `:MEAS:<CURR|VOLT|RES>?` command or the `:MEAS?` command. See [Figure 1-2](#) for the spot measurement.

Example `ioObj.WriteString(":MEAS:RES?")`
`ioObj.WriteString(":FORM:ELEM:SENS RES,STAT")`
`ioObj.WriteString(":MEAS?")`

NOTE

For the `:MEAS?` command, the measurement parameters are specified by `:SENS:FUNC` and the returned data is specified by `:FORM:ELEM:SENS`.

Setting the Measurement Speed

Measurement speed is set by the `:SENS:<CURR|VOLT|RES>:APER` or `:SENS:<CURR|VOLT|RES>:NPLC` command.

Example `ioObj.WriteString(":SENS:CURR:APER 1E-4")` '0.1 ms
`ioObj.WriteString(":SENS:CURR:NPLC 1")` '1 Power Line Cycle

Setting the Measurement Range

Measurement range is set by the `:SENS:<CURR|VOLT|RES>:RANG` command. And the auto range operation is enabled/disabled by the `:SENS:<CURR|VOLT|RES>:RANG:AUTO` command. The lower limit for the auto range operation is set by the `:SENS:<CURR|VOLT|RES>:RANG:AUTO:LLIM` command. The upper limit for the resistance measurement auto range operation is set by the `:SENS:RES:RANG:AUTO:ULIM` command.

For current measurement and voltage measurement, the maximum measurement range depends on the limit/compliance value.

Example

```
ioObj.WriteString(":SENS:CURR:RANG:AUTO OFF")
ioObj.WriteString(":SENS:CURR:RANG 0.1")           '100 mA fixed

ioObj.WriteString(":SENS:RES:RANG:AUTO ON")
ioObj.WriteString(":SENS:RES:RANG:AUTO:LLIM 2")   '2 ohm limit
ioObj.WriteString(":SENS:RES:RANG:AUTO:ULIM 200") '200 ohm limit
```

Setting the Measurement Auto Range Operation

Automatic measurement ranging operation mode, normal, resolution, or speed is set by the `:SENS:<CURR|VOLT>:RANG:AUTO:MODE` command. And the threshold rate for the operation is set by the `:SENS:<CURR|VOLT>:RANG:AUTO:THR` command.

Example

```
ioObj.WriteString(":SENS:CURR:RANG:AUTO:MODE NORM") 'Normal
ioObj.WriteString(":SENS:CURR:RANG:AUTO:THR 80")

ioObj.WriteString(":SENS:CURR:RANG:AUTO:MODE RES") 'Resolution
ioObj.WriteString(":SENS:CURR:RANG:AUTO:THR 80")

ioObj.WriteString(":SENS:CURR:RANG:AUTO:MODE SPE") 'Speed
ioObj.WriteString(":SENS:CURR:RANG:AUTO:THR 80")
```

Setting the Measurement Trigger

Measurement trigger is simply set by the `:TRIG<:ACQ | [:ALL]>:SOUR`, `:TRIG<:ACQ | [:ALL]>:TIM`, `:TRIG<:ACQ | [:ALL]>:COUN`, and `:TRIG<:ACQ | [:ALL]>:DEL` commands. See [Figures 1-2](#), [1-3](#), and [1-4](#).

Example

```
ioObj.WriteString(":TRIG:SOUR TIM")
ioObj.WriteString(":TRIG:TIM 4E-3")           'Interval 4 ms
ioObj.WriteString(":TRIG:COUN 11")           '11 points
ioObj.WriteString(":TRIG:ACQ:DEL 2E-3")     'Meas delay 2 ms
```

NOTE

If measurement channels are set as shown below, the measurement starts simultaneously.

- Trigger source is set to the same mode.
- Delay time is set to the same value.
- Measurement wait time control is set to OFF.
- Measurement ranging mode is set to the fixed mode.

NOTE

If you want to use arm trigger, use the `:ARM<:ACQ | [:ALL]>:SOUR`, `:ARM<:ACQ | [:ALL]>:TIM`, `:ARM<:ACQ | [:ALL]>:COUN`, and `:ARM<:ACQ | [:ALL]>:DEL` commands. For more details, see *SCPI Command Reference*.

Figure 1-3 To Perform Staircase Sweep Output and Measurement

Staircase sweep source :FUNC DC, :CURR:MODE SWE or :VOLT:MODE SWE

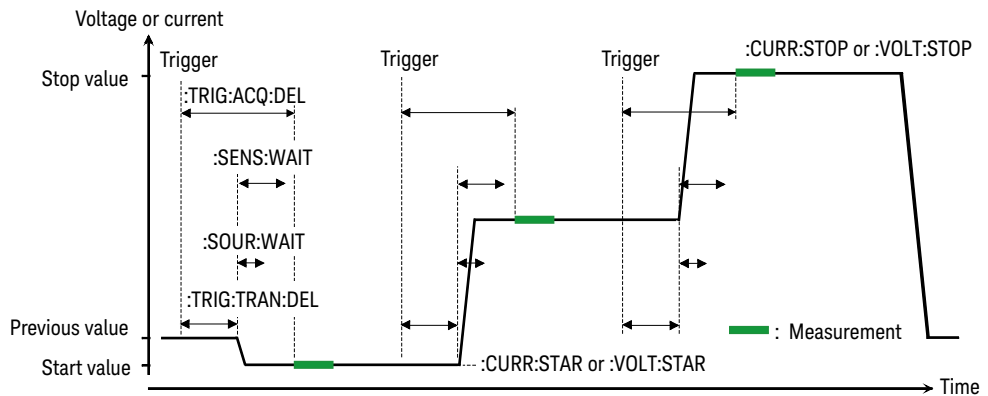
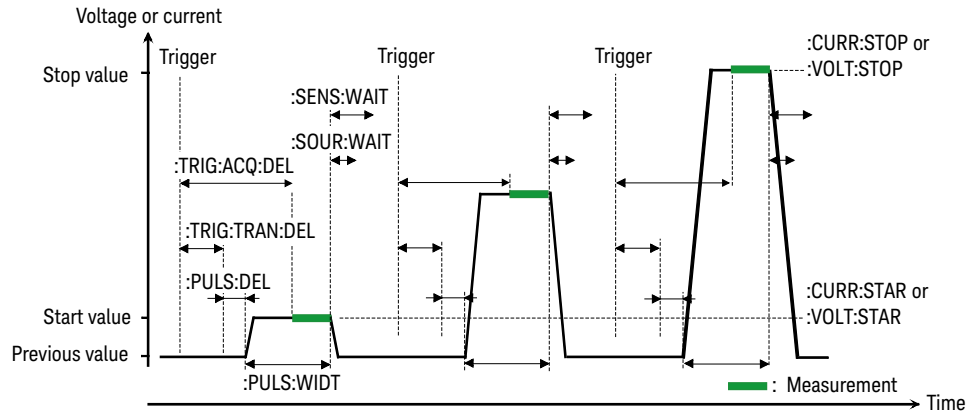

Figure 1-4 To Perform Pulsed Sweep Output and Measurement

Pulsed sweep source :FUNC PULS, :CURR:MODE SWE or :VOLT:MODE SWE



Setting the Measurement Wait Time

Measurement wait time is set by the :SENS:WAIT commands. See [Figures 1-3](#) and [1-4](#) for the wait time.

Example

```
ioObj.WriteString(":SENS:WAIT OFF")           'Wait = 0 s
ioObj.WriteString(":SENS:WAIT ON")
ioObj.WriteString(":SENS:WAIT:AUTO OFF")
ioObj.WriteString(":SENS:WAIT:OFFS 10E-3") 'Wait = 10 ms

ioObj.WriteString(":SENS:WAIT ON")
ioObj.WriteString(":SENS:WAIT:AUTO ON")
ioObj.WriteString(":SENS:WAIT:OFFS 10E-3")
ioObj.WriteString(":SENS:WAIT:GAIN 1")'Wait = 10 ms + initial wait
```

Performing Sweep Measurement

Staircase sweep measurement is performed as shown below.

1. Set the staircase sweep source and the required source functions. For details, see [“Controlling the Source Output” on page 17](#).
2. Set the required measurement functions. For details, see previous topics in this section.
3. Set the trigger condition. See [“Setting the Source Output Trigger” on page 22](#) and [“Setting the Measurement Trigger” on page 28](#).
4. Enable the channel. See [“Enabling the Measurement Channel” on page 26](#).
The channel starts output set by the `:SOUR:<CURR|VOLT>` command.
5. Execute the `:INIT` command to start measurement.

For the programming example, see [“Staircase Sweep Measurements” on page 54](#).

NOTE

To get measurement result data, use a `:FETC` subsystem command. For example, the `:FETC:CURR?` command returns the latest current measurement data. The `:FETC?` command returns the latest data for the parameters specified by the `:FORM:ELEM:SENS` command.

For details on the `:FETC` subsystem commands, see *SCPI Command Reference*.

Stopping Measurement

Measurement is stopped by the `:OUTP OFF` command.

Example `ioObj.WriteString(":OUTP OFF")`

Using the Math Function

This section describes how to use the math function.

- “Defining a Math Expression”
- “Deleting an User Defined Math Expression”
- “Enabling or Disabling the Math Function”
- “Reading Math Result Data”

Defining a Math Expression

Math expression is defined by the :CALC:MATH[:EXPR] commands.

Example `ioObj.WriteString(":CALC:MATH:NAME ""DiffV""")
ioObj.WriteString(":CALC:MATH:DEF (SOUR-VOLT)")
ioObj.WriteString(":CALC:MATH:UNIT ""V""")`

Deleting an User Defined Math Expression

Math expression is deleted by the :CALC:MATH[:EXPR]:DEL commands. The commands do not delete the predefined math expression.

Example `ioObj.WriteString(":CALC:MATH:DEL ""DiffV""") 'Deletes DiffV
ioObj.WriteString(":CALC:MATH:DEL:ALL") 'Deletes all`

Enabling or Disabling the Math Function

Math function is set by the :CALC:MATH:STAT command.

Example `ioObj.WriteString(":CALC:MATH:STAT ON")`

Reading Math Result Data

Math result data is read by the :CALC:MATH:DATA? commands.

Example `ioObj.WriteString(":CALC:MATH:DATA:LAT?") 'Latest data
ioObj.WriteString(":CALC:MATH:DATA?") 'All data`

NOTE

To specify the data to obtain, use the :FORM:ELEM:CALC command.

Performing the Limit Test

Limit test is performed as shown below. Limit test is not available for B2901BL.

1. Set the required source condition. For details, see [“Controlling the Source Output” on page 17](#).
2. Set the required measurement condition. For details, see [“Controlling the Measurement Function” on page 26](#).
3. Set the composite limit test. See [“Setting the Composite Limit Test” on page 35](#).
4. Set the individual limit tests. See [“Setting Individual Limit Tests” on page 35](#).
5. Set the trigger condition. See [“Setting the Source Output Trigger” on page 22](#) and [“Setting the Measurement Trigger” on page 28](#).
6. Enable the channel. See [“Enabling the Measurement Channel” on page 26](#).
The channel starts output set by the :SOUR:<CURR|VOLT> command.
7. Execute the :INIT command to start limit test.
Note that the DC source channel applies the value set by the :SOUR:<CURR|VOLT>:TRIG command when it is triggered, even if the channel is applying the value set by the :SOUR:<CURR|VOLT> command.
8. Read limit test result. See [“Reading Limit Test Result” on page 35](#).

For the programming example, see [“Pass/Fail Judgment and Math Function” on page 74](#).

Setting the Composite Limit Test

Composite limit test is set by the :CALC:CLIM commands and enabled by the :CALC:CLIM:STAT ON command. To perform a limit test, at least one individual limit test must be set and enabled.

Example

```
ioObj.WriteString(":CALC:CLIM:CLE")           'Clears result now
ioObj.WriteString(":CALC:CLIM:MODE GRAD")     'Sets grading mode
ioObj.WriteString(":CALC:CLIM:UPD END")       'Sends result at the end
ioObj.WriteString(":CALC:CLIM:STAT ON")      'Composite limit test on
```

NOTE

If you want to use the GPIO port for sending a pass/fail bit pattern, use the :CALC:DIG commands to specify the output port. See *SCPI command reference*.

If you want to use the null offset function for canceling the offset value from the measurement data automatically, use the :CALC:OFFS commands. See *SCPI command reference*.

Setting Individual Limit Tests

Individual limit test is set by the :CALC:LIM commands and the :CALC:FEED command. And each limit test is enabled by the :CALC:LIM:STAT ON command.

Example

```
ioObj.WriteString(":CALC:FEED CURR")         'Specifies feed data
ioObj.WriteString(":CALC:LIM:STAT ON")      'Limit test on
ioObj.WriteString(":CALC:LIM:FUNC LIM")     'Selects limit test
ioObj.WriteString(":CALC:LIM:UPP +3.5E-2")  'Sets upper limit
ioObj.WriteString(":CALC:LIM:LOW +3E-2")    'Sets lower limit
```

Reading Limit Test Result

Limit test result is read by the :CALC:DATA? commands.

Fail status of the individual limit test is read by the :CALC:LIM:FAIL? command.

Example

```
ioObj.WriteString(":CALC:DATA:LAT?")        'Latest data
ioObj.WriteString(":CALC:DATA?")           'All data
ioObj.WriteString(":CALC:LIM:FAIL?")       '1:failed, 0:passed
```

NOTE

To specify the data to obtain, use the :FORM:ELEM:CALC command.

Using the Trace Buffer

This section describes how to use the trace buffer.

- “Setting the Trace Buffer”
- “Reading the Trace Data”

Figure 1-5

Trace Buffer and Data Flow

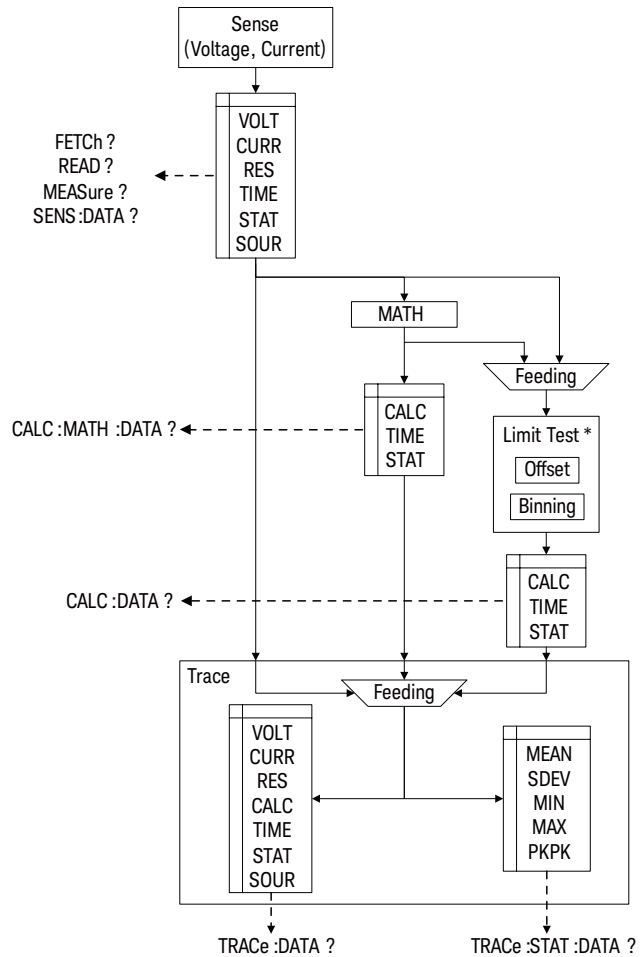

* Limit Test is not available for B2901BL.

Setting the Trace Buffer

Trace buffer is set by the :TRAC commands.

Example

```
ioObj.WriteString(":TRAC:CLE")           'Clears trace buffer
ioObj.WriteString(":TRAC:POIN 1000")     'Sets buffer size
ioObj.WriteString(":TRAC:FEED SENS")     'Specifies data to feed
ioObj.WriteString(":TRAC:FEED:CONT NEXT") 'Enables write buffer
ioObj.WriteString(":TRAC:TST:FORM DELT")
```

NOTE

The :TRAC:TST:FORM command is used to specify the timestamp data format, delta (DELT) or absolute (ABS).

To specify the data to collect, use the :FORM:ELEM:SENS command for the measurement data or the :FORM:ELEM:CALC command for the calculation data.

Reading the Trace Data

All data in the trace buffer is read by the :TRAC:DATA? command.

Statistical data of the data stored in the trace buffer is read by the :TRAC:STAT:DATA? command. Previously, the type of the statistical data to read must be selected by the :TRAC:STAT:FORM command.

The :TRAC:STAT:FORM command selects one from the following statistical data.

- MEAN: Mean value
- SDEV: Standard deviation
- PKPK: Peak to peak value
- MIN: Minimum value
- MAX: Maximum value

Example

```
ioObj.WriteString(":TRAC:DATA?")           'Reads all data
ioObj.WriteString(":TRAC:STAT:FORM MEAN")
ioObj.WriteString(":TRAC:STAT:DATA?")     'Reads statistical data
```

Using Program Memory

This section describes how to use program memory.

- “Defining a Memory Program”
- “Deleting a Program”
- “Controlling the Program Operation”

Defining a Memory Program

Memory program is defined by the :PROG:NAME and :PROG:DEF commands.

Example

```
ioObj.WriteString(":PROG:NAME ""sample""")
ioObj.WriteString(":PROG:DEF #213:OUTP:STAT ON") 'Definite length

ioObj.WriteString(":PROG:NAME ""sample1""")
ioObj.WriteString(":PROG:DEF #0:OUTP:STAT ON") 'Indefinite length
```

Deleting a Program

Memory program is deleted by the :PROG:DEL commands.

Example

```
ioObj.WriteString(":PROG:DEL:ALL") 'Deletes all

ioObj.WriteString(":PROG:NAME ""sample1""")
ioObj.WriteString(":PROG:DEL") 'Deletes sample1
```

Controlling the Program Operation

Memory program is controlled by the :PROG:NAME command and the :PROG:EXEC or :PROG:STAT command. The :PROG[:SEL]:STAT command needs a parameter used to control the operation or change the status. The parameter must be RUN to change the status to running, PAUS to change it to paused, CONT to change it from paused to running, STOP to change it to stopped, or STEP to perform step execution.

Example

```
ioObj.WriteString(":PROG:NAME ""sample""")
ioObj.WriteString(":PROG:EXEC")
ioObj.WriteString("*OPC?") : s = ioObj.ReadString()

ioObj.WriteString(":PROG:NAME ""sample""")
ioObj.WriteString(":PROG:STAT RUN")
ioObj.WriteString("*OPC?") : s = ioObj.ReadString()
ioObj.WriteString(":PROG:STAT STOP")
```

Controlling the Keysight B2900 Using Program Memory

2 Programming Examples

Preparations	43
Spot Measurements	47
Pulsed Spot Measurements	50
Staircase Sweep Measurements	54
Pulsed Sweep Measurements	58
List Sweep Measurements	62
Pulsed List Sweep Measurements	66
Sampling Measurements	70
Pass/Fail Judgment and Math Function	74
Using Program Memory	78
Reading Binary Data	81
Performing MOSFET Id-Vd Measurements	83

This chapter explains programming example.

NOTE

About Numeric Suffix

Command header may be accompanied by a numeric suffix *c* for specifying the SMU (source/measure unit) channel. *c* must be 1 for using the channel 1, or 2 for using the channel 2. Abbreviating *c* gives the same result as specifying 1.

For example, the :OUTP ON command and the :OUTP1 ON command enable the channel 1, and the :OUTP2 ON command enables the channel 2.

NOTE

About Example Program Code

Example programs described in this section have been written in the Microsoft Visual Basic .NET language. The examples are provided as a subprogram that can be run with the project template shown in [Table 2-1](#). To run the program, insert the example subprogram or your subprogram instead of the B2900control subprogram in the template.

NOTE

To Start Program

If you create the measurement program by using the example code shown in [Table 2-1](#), the program can be run by clicking the Run button on the Visual Basic main window.

Preparations

This section provides the basic information for programming of the automatic measurement using the Keysight B2900, Keysight IO Libraries, and Microsoft Visual Basic .NET.

- “To Create Your Project Template”
- “To Create Measurement Program”

NOTE

To execute the example programs in this chapter, you need to install Keysight GPIB interface, Keysight IO Libraries Suite, and Microsoft Visual Basic .NET on your computer.

To Create Your Project Template

Before starting programming, create your project template, and keep it as your reference. It will remove the conventional task in the future programming. This section explains how to create a project template.

- Step 1. Connect Keysight B2900 (e.g. GPIB address 23) to the computer via GPIB.
- Step 2. Launch Visual Basic .NET and create a new project. The project type should be Console Application to simplify the programming.
- Step 3. Add the following references to the project.
 - VISA COM 3.0 Type Library
 - Ivi.Visa.Interop
 - System.IO
- Step 4. Open a module (e.g. Module1.vb) in the project. And enter a program code as template. See [Table 2-1](#) for example.
- Step 5. Save the project as your template (e.g. \test\my_temp).

To Create Measurement Program

Create the measurement program as shown below. The following procedure needs your project template. If the procedure does not fit your programming environment, arrange it to suit your environment.

Step 1. Plan the automatic measurements. Then decide the following items:

- Measurement devices
Discrete, packaged, on-wafer, and so on.
- Parameters/characteristics to be measured
 h_{FE} , V_{th} , sheet resistance, and so on.
- Measurement method
Spot measurement, staircase sweep measurement, and so on.

Step 2. Make a copy of your project template (e.g. `\test\my_temp` to `\test\dev_a\my_temp`).

Step 3. Rename the copy (e.g. `\test\dev_a\my_temp` to `\test\dev_a\spot1V`).

Step 4. Launch Visual Basic .NET.

Step 5. Open the project (e.g. `\test\dev_a\spot1V`).

Step 6. Open the module that contains the template code as shown in [Table 2-1](#). On the code window, complete the B2900control subprogram.

Step 7. Insert the code to display, store, or calculate data into the subprogram.

Step 8. Save the project (e.g. `\test\dev_a\spot1V`).

Table 2-1 Example Template Program Code

```

Module Module1
    Sub Main() '1
        Dim rm As Ivi.Visa.Interop.ResourceManager
        Dim ioObj As Ivi.Visa.Interop.FormattedIO488
        Dim ifAddress As String = "23"
        Dim filename As String = ""
        Dim filedata As String = "Result: "
        Dim s As String = ""

        Try '9
            rm = New Ivi.Visa.Interop.ResourceManager
            ioObj = New Ivi.Visa.Interop.FormattedIO488
            Try
                ioObj.IO = rm.Open("GPIB0:" + ifAddress + "::INSTR")
                ioObj.IO.Timeout = 60000
                ioObj.IO.TerminationCharacter = 10
                ioObj.IO.TerminationCharacterEnabled = True
            Catch ex As Exception
                Console.WriteLine("An error occurred: " + ex.Message)
            End Try

            B2900control(ioObj, s, filename) '21
            Console.Write(filedata + s)
            MsgBox("Click OK to close the console window.", vbOKOnly, "")

            FileOpen(1, filename, OpenMode.Output, OpenAccess.Write,
OpenShare.LockReadWrite) '25
            Print(1, filedata + s)
            FileClose(1)

            ioObj.IO.Close() '29
            System.Runtime.InteropServices.Marshal.ReleaseComObject(ioObj)
            System.Runtime.InteropServices.Marshal.ReleaseComObject(rm)
            Catch ex As Exception
                Console.WriteLine("An error occurred: " + ex.Message)
            End Try
        End Sub

        Sub B2900control(ByVal ioObj As Ivi.Visa.Interop.FormattedIO488, ByRef s As String,
ByRef filename As String) '37
            filename = "C:/temp/resultdata1.txt"
        End Sub
    End Module

```

Line	Description
1 to 8	Beginning of the Main subprogram. And defines the variables used in this program.
9 to 20	Establishes the connection with the B2900 specified by the GPIB address ifAddress = 23 on the interface GPIB0.

Programming Examples
Preparations

```

Module Module1

Sub Main() '1
    Dim rm As Ivi.Visa.Interop.ResourceManager
    Dim ioObj As Ivi.Visa.Interop.FormattedIO488
    Dim ifAddress As String = "23"
    Dim filename As String = ""
    Dim filedata As String = "Result: "
    Dim s As String = ""

    Try '9
        rm = New Ivi.Visa.Interop.ResourceManager
        ioObj = New Ivi.Visa.Interop.FormattedIO488
        Try
            ioObj.IO = rm.Open("GPIB0::" + ifAddress + "::INSTR")
            ioObj.IO.Timeout = 60000
            ioObj.IO.TerminationCharacter = 10
            ioObj.IO.TerminationCharacterEnabled = True
        Catch ex As Exception
            Console.WriteLine("An error occurred: " + ex.Message)
        End Try

        B2900control(ioObj, s, filename) '21
        Console.Write(filedata + s)
        MsgBox("Click OK to close the console window.", vbOKOnly, "")

        FileOpen(1, filename, OpenMode.Output, OpenAccess.Write, '25
        OpenShare.LockReadWrite)
        Print(1, filedata + s)
        FileClose(1)

        ioObj.IO.Close() '29
        System.Runtime.InteropServices.Marshal.ReleaseComObject(ioObj)
        System.Runtime.InteropServices.Marshal.ReleaseComObject(rm)
        Catch ex As Exception
            Console.WriteLine("An error occurred: " + ex.Message)
        End Try
    End Sub

    Sub B2900control(ByVal ioObj As Ivi.Visa.Interop.FormattedIO488, ByRef s As String, '37
    ByRef filename As String)
        filename = "C:/temp/resultdata1.txt"
    End Sub

End Module

```

Line	Description
21 to 23	Calls the B2900control subprogram. And displays the result data in a console window.
25 to 27	Saves the result data to a file specified by filename.
29 to 35	Breaks the connection with the B2900.
37 to 39	B2900control subprogram. Measurement program code should be entered here.

Spot Measurements

A program example of spot measurements is shown in [Table 2-3](#). This example is used to apply voltage and measure current.

Table 2-2 Spot Measurement Commands

Function	Command
Selects source function	<code>[:SOUR[c]]:FUNC:MODE <i>v-or-c</i></code>
Sets source output range	<code>[:SOUR[c]]:v-or-c:RANG:AUTO <ON OFF></code> <code>[:SOUR[c]]:v-or-c:RANG <i>value</i></code>
Sets source output value	<code>[:SOUR[c]]:v-or-c <i>value</i></code>
Sets measurement function	<code>:SENS[c]:FUNC "<i>func</i>", "<i>func</i>", "<i>func</i>"</code>
Sets measurement range	<code>:SENS[c]:<i>func</i>:RANG:AUTO <ON OFF></code> <code>:SENS[c]:<i>func</i>:RANG <i>value</i></code>
Sets aperture time in seconds or by using NPLC value	<code>:SENS[c]:<i>func</i>:APER <i>time</i></code> <code>:SENS[c]:<i>func</i>:NPLC <i>value</i></code>
Sets limit (compliance) value	<code>:SENS[c]:v-or-c:PROT <i>value</i></code>
Enables or disables channel	<code>:OUTP[c] <ON OFF></code>
Initiates measurement and reads result data (latest data)	<code>:MEAS? [<i>chanlist</i>]</code> <code>:MEAS:<i>func</i>? [<i>chanlist</i>]</code>

v-or-c is VOLT for voltage source or limit (compliance), or CURR for current source or limit (compliance).

func is VOLT for voltage measurement, CURR for current measurement, or RES for resistance measurement.

Programming Examples

Spot Measurements

chanlist is (@1) for selecting the channel 1 only, (@2) for selecting the channel 2 only, or (@1,2), (@1:2), (@2,1), or (@2:1) for selecting both channels 1 and 2. Abbreviating this parameter sets *chanlist* = (@1) for the 1-channel models, and *chanlist* = (@1,2) for the 2-channel models.

Table 2-3 Spot Measurement Example

```

Sub B2900control(ByVal ioObj As Ivi.Visa.Interop.FormattedIO488, ByRef s As String, ByRef
filename As String)
    filename = "C:/temp/FixedDc1.txt" '2

    ioObj.WriteString("*RST") ' Reset

    Try ' Set voltage output to 0.1 V '6
        ioObj.WriteString(":sour:func:mode volt")
        ioObj.WriteString(":sour:volt 0.1")

        ' Set auto-range current measurement
        ioObj.WriteString(":sens:func ""curr""") '11
        ioObj.WriteString(":sens:curr:rang:auto on")
        ioObj.WriteString(":sens:curr:nplc 0.1")
        ioObj.WriteString(":sens:curr:prot 0.1")

    Catch ex As Exception
        Console.WriteLine("An error occurred: " + ex.Message)
    End Try

    ' Turn on output switch '21
    ioObj.WriteString(":outp on")

    Try ' Initiate measurement and retrieve measurement result '23
        ioObj.WriteString(":meas:curr? (@1)")
        s = ioObj.ReadString()

    Catch ex As Exception
        Console.WriteLine("An error occurred: " + ex.Message)
    End Try
End Sub

```

Line	Description
2	Defines the file name used for saving the result data.
4	Resets the B2900.
6 to 8	Sets the voltage source function. And sets the source value to 0.1 V.
11 to 14	Sets the current measurement function and the auto range measurement. And sets the aperture time to 0.1 PLC and the current limit (compliance) value to 0.1 A.
21	Enables the channel. And starts source output.
23 to 25	Reads the measurement result data.

Measurement Result Example **Result:** +3.034160E-02

Pulsed Spot Measurements

A program example of pulsed spot measurements is shown in [Table 2-5](#). This example is used to apply pulsed voltage and measure current three times.

Table 2-4 Pulsed Spot Measurement Commands

Function	Command
Selects source function	<code>[:SOUR[c]]:FUNC:MODE <i>v-or-c</i></code>
Sets pulse output	<code>[:SOUR[c]]:FUNC[:SHAP] PULS</code>
Sets source output range	<code>[:SOUR[c]]:v-or-c:RANG:AUTO <ON OFF></code> <code>[:SOUR[c]]:v-or-c:RANG <i>value</i></code>
Sets source output value	<code>[:SOUR[c]]:v-or-c <i>value</i></code>
Sets pulse peak value	<code>[:SOUR[c]]:v-or-c:TRIG <i>value</i></code>
Sets pulse delay time	<code>[:SOUR[c]]:PULS:DEL <i>time</i></code>
Sets pulse width	<code>[:SOUR[c]]:PULS:WIDT <i>time</i></code>
Sets measurement function	<code>:SENS[c]:FUNC "<i>func</i>"[, "<i>func</i>"[, "<i>func</i>"]]</code>
Sets measurement range	<code>:SENS[c]:<i>func</i>:RANG:AUTO <ON OFF></code> <code>:SENS[c]:<i>func</i>:RANG <i>value</i></code>
Sets aperture time in seconds or by using NPLC value	<code>:SENS[c]:<i>func</i>:APER <i>time</i></code> <code>:SENS[c]:<i>func</i>:NPLC <i>value</i></code>
Sets limit (compliance) value	<code>:SENS[c]:v-or-c:PROT <i>value</i></code>
Selects trigger source	<code>:TRIG[c]<:ACQ :TRAN [:ALL]>:SOUR <i>source</i></code>
Sets interval of timer trigger	<code>:TRIG[c]<:ACQ :TRAN [:ALL]>:TIM <i>time</i></code>
Sets trigger count	<code>:TRIG[c]<:ACQ :TRAN [:ALL]>:COUN <i>value</i></code>
Sets trigger delay time	<code>:TRIG[c]<:ACQ :TRAN [:ALL]>:DEL <i>time</i></code>

Function	Command
Enables or disables channel	:OUTP[c] <ON OFF>
Initiates specified action	:INIT<:ACQ :TRAN [:ALL]> [chanlist]
Reads result data (latest data)	:FETC[:SCAL]? [chanlist]
	:FETC[:SCAL]:type? [chanlist]
Reads result data (array data)	:FETC:ARR? [chanlist]
	:FETC:ARR:type? [chanlist]

v-or-c is VOLT for voltage source or limit (compliance), or CURR for current source or limit (compliance).

func is VOLT for voltage measurement, CURR for current measurement, or RES for resistance measurement.

source is AINT for the automatic trigger, BUS for the remote interface trigger command, TIM for the internal timer, INT n for a signal from the internal bus ($n = 1$ or 2), EXT m for a signal from the GPIO pin m ($m = 1$ to 14), or LAN for the LXI trigger.

type is VOLT for voltage data, CURR for current data, RES for resistance data, SOUR for source output data, STAT for status data, or TIME for time data.

chanlist is (@1) for selecting the channel 1 only, (@2) for selecting the channel 2 only, or (@1,2), (@1:2), (@2,1), or (@2:1) for selecting both channels 1 and 2. Abbreviating this parameter sets *chanlist* = (@1) for the 1-channel models, and *chanlist* = (@1,2) for the 2-channel models.

Table 2-5 Pulsed Spot Measurement Example

<pre> Sub B2900control(ByVal ioObj As Ivi.Visa.Interop.FormattedIO488, ByRef s As String, ByRef filename As String) filename = "C:/temp/FixedPulse1.txt" '2 ioObj.WriteString("*RST") ' Reset Try ' Set voltage pulse output ioObj.WriteString(":sour:func:mode volt") '7 ioObj.WriteString(":sour:func:shap puls") ' Set base/peak voltages to 0.0/0.1 V ioObj.WriteString(":sour:volt 0") '11 ioObj.WriteString(":sour:volt:trig 0.1") ' Set delay/width to 500 us/1 ms ioObj.WriteString(":sour:puls:del 0.5e-3") '15 ioObj.WriteString(":sour:puls:widt 1.0e-3") ' Set 100 mA fixed-range current measurement ioObj.WriteString(":sens:func ""curr""") '19 ioObj.WriteString(":sens:curr:rang:auto off") ioObj.WriteString(":sens:curr:rang 100e-3") ioObj.WriteString(":sens:curr:aper 1e-4") ioObj.WriteString(":sens:curr:prot 0.1") ' Adjust trigger timing parameters ioObj.WriteString(":trig:tran:del 1.5e-3") '26 ioObj.WriteString(":trig:acq:del 2.9e-3") </pre>	
Line	Description
2	Defines the file name used for saving the result data.
4	Resets the B2900.
7 to 8	Sets the voltage source function. And sets the pulse output function.
11 to 12	Sets the pulse base voltage and the pulse peak voltage.
15 to 16	Sets the pulse delay time and the pulse width.
19 to 23	Sets the current measurement function and the 100 mA fixed range measurement. And sets the aperture time to 0.1 ms and the current limit (compliance) value to 0.1 A.
26 to 27	Sets the transient (source) delay time and the acquire (measurement) delay time.

```

' Generate 3 triggers in 4 ms period
ioObj.WriteString(":trig:sour tim")           ' 30
ioObj.WriteString(":trig:tim 4e-3")
ioObj.WriteString(":trig:coun 3")

Catch ex As Exception
  Console.WriteLine("An error occurred: " + ex.Message)
End Try

' Turn on output switch
ioObj.WriteString(":outp on")                 ' 39

' Initiate transition and acquire
ioObj.WriteString(":init (@1)")              ' 42

Try ' Retrieve measurement result            ' 44
  ioObj.WriteString(":fetc:arr:curr? (@1)")
  s = ioObj.ReadString()

Catch ex As Exception
  Console.WriteLine("An error occurred: " + ex.Message)
End Try
End Sub

```

Line	Description
30 to 32	Sets the timer trigger source. And sets the trigger interval to 4 ms, and the trigger count to 3. The B2900 will perform the pulsed spot measurement three times.
39	Enables the channel. And starts source output.
42	Starts pulse output and pulsed spot measurement.
44 to 46	Reads the measurement result data.

Measurement Result Example **Result:** +3.033990E-02,+3.034060E-02,+3.034120E-02

Staircase Sweep Measurements

A program example of staircase sweep measurements is shown in [Table 2-7](#). This example is used to apply sweep voltage and measure current at each sweep step.

Table 2-6 Staircase Sweep Measurement Commands

Function	Command
Selects source function	<code>[[:SOUR[c]]:FUNC:MODE <i>v-or-c</i></code>
Sets sweep output	<code>[[:SOUR[c]]:v-or-c:MODE SWE</code>
Sets output range when starting sweep	<code>[[:SOUR[c]]:v-or-c:RANG <i>value</i></code>
Sets source output value	<code>[[:SOUR[c]]:v-or-c <i>value</i></code>
Sets sweep start or stop value	<code>[[:SOUR[c]]:v-or-c:<STAR STOP> <i>value</i></code>
Sets sweep center or span value	<code>[[:SOUR[c]]:v-or-c:<CENT SPAN> <i>value</i></code>
Sets sweep step value	<code>[[:SOUR[c]]:v-or-c:STEP <i>value</i></code>
Sets number of sweep steps	<code>[[:SOUR[c]]:v-or-c:POIN <i>value</i></code> <code>[[:SOUR[c]]:SWE:POIN <i>value</i></code>
Selects sweep source ranging mode	<code>[[:SOUR[c]]:SWE:RANG <BEST FIX AUTO></code>
Selects sweep direction	<code>[[:SOUR[c]]:SWE:DIR <UP DOWN></code>
Selects sweep linear or log	<code>[[:SOUR[c]]:SWE:SPAC <LIN LOG></code>
Selects sweep single or double	<code>[[:SOUR[c]]:SWE:STA <SING DOUB></code>
Sets measurement function	<code>:SENS[c]:FUNC "<i>func</i>", "<i>func</i>", "<i>func</i>"</code>
Sets measurement range	<code>:SENS[c]:<i>func</i>:RANG:AUTO <ON OFF></code> <code>:SENS[c]:<i>func</i>:RANG <i>value</i></code>
Sets aperture time in seconds or by using NPLC value	<code>:SENS[c]:<i>func</i>:APER <i>time</i></code> <code>:SENS[c]:<i>func</i>:NPLC <i>value</i></code>

Function	Command
Sets limit (compliance) value	:SENS[c]: <i>v-or-c</i> :PROT <i>value</i>
Selects trigger source	:TRIG[c]<:ACQ :TRAN [:ALL]>:SOUR <i>source</i>
Sets interval of timer trigger	:TRIG[c]<:ACQ :TRAN [:ALL]>:TIM <i>time</i>
Sets trigger count	:TRIG[c]<:ACQ :TRAN [:ALL]>:COUN <i>value</i>
Sets trigger delay time	:TRIG[c]<:ACQ :TRAN [:ALL]>:DEL <i>time</i>
Enables or disables channel	:OUTP[c] <ON OFF>
Initiates specified action	:INIT<:ACQ :TRAN [:ALL]> [<i>chanlist</i>]
Reads result data (array data)	:FETC:ARR? [<i>chanlist</i>] :FETC:ARR: <i>type</i> ? [<i>chanlist</i>]

v-or-c is VOLT for voltage source or limit (compliance), or CURR for current source or limit (compliance).

func is VOLT for voltage measurement, CURR for current measurement, or RES for resistance measurement.

source is AINT for the automatic trigger, BUS for the remote interface trigger command, TIM for the internal timer, INT n for a signal from the internal bus ($n = 1$ or 2), EXT m for a signal from the GPIO pin m ($m = 1$ to 14), or LAN for the LXI trigger.

type is VOLT for voltage data, CURR for current data, RES for resistance data, SOUR for source output data, STAT for status data, or TIME for time data.

chanlist is (@1) for selecting the channel 1 only, (@2) for selecting the channel 2 only, or (@1,2), (@1:2), (@2,1), or (@2:1) for selecting both channels 1 and 2. Abbreviating this parameter sets *chanlist* = (@1) for the 1-channel models, and *chanlist* = (@1,2) for the 2-channel models.

**Measurement
Result Example**

Result: +1.842730E-07,+6.775910E-03,+1.519010E-02,+2.277660E-02,+3.036230E-02

Table 2-7 Staircase Sweep Measurement Example

<pre> Sub B2900control(ByVal ioObj As Ivi.Visa.Interop.FormattedIO488, ByRef s As String, ByRef filename As String) filename = "C:/temp/StaircaseSweep1.txt" '2 ioObj.WriteString("*RST") ' Reset Try ' Set voltage output from 0 V to 0.1 V, 5 steps ioObj.WriteString(":sour:func:mode volt") ioObj.WriteString(":sour:volt:mode swe") ioObj.WriteString(":sour:volt:star 0") ioObj.WriteString(":sour:volt:stop 0.1") ioObj.WriteString(":sour:volt:poin 5") '6 ' Set auto-range current measurement ioObj.WriteString(":sens:func ""curr""") ioObj.WriteString(":sens:curr:nplc 0.1") ioObj.WriteString(":sens:curr:prot 0.1") '14 ' Generate 5 triggers by automatic internal algorithm ioObj.WriteString(":trig:sour aint") ioObj.WriteString(":trig:coun 5") '19 Catch ex As Exception Console.WriteLine("An error occurred: " + ex.Message) End Try ' Turn on output switch ioObj.WriteString(":outp on") '27 ' Initiate transition and acquire ioObj.WriteString(":init (@1)") '30 Try ' Retrieve measurement result ioObj.WriteString(":fetc:arr:curr? (@1)") s = ioObj.ReadString() '32 Catch ex As Exception Console.WriteLine("An error occurred: " + ex.Message) End Try End Sub </pre>	
Line	Description
2	Defines the file name used for saving the result data.
4	Resets the B2900.
6 to 11	Sets the voltage sweep output function. And sets the sweep output from 0 to 0.1 V in 0.02 V step (5 points).
14 to 16	Sets the current measurement function. And sets the aperture time to 0.1 PLC and the current limit (compliance) value to 0.1 A. Auto range is ON with the default setting.

```

Sub B2900control(ByVal ioObj As Ivi.Visa.Interop.FormattedIO488, ByRef s As String, ByRef
filename As String)
    filename = "C:/temp/StaircaseSweep1.txt" '2

    ioObj.WriteString("*RST") ' Reset

    Try ' Set voltage output from 0 V to 0.1 V, 5 steps '6
        ioObj.WriteString(":sour:func:mode volt")
        ioObj.WriteString(":sour:volt:mode swe")
        ioObj.WriteString(":sour:volt:star 0")
        ioObj.WriteString(":sour:volt:stop 0.1")
        ioObj.WriteString(":sour:volt:poin 5")

        ' Set auto-range current measurement
        ioObj.WriteString(":sens:func ""curr""") '14
        ioObj.WriteString(":sens:curr:nplc 0.1")
        ioObj.WriteString(":sens:curr:prot 0.1")

        ' Generate 5 triggers by automatic internal algorithm
        ioObj.WriteString(":trig:sour aint") '19
        ioObj.WriteString(":trig:coun 5")

    Catch ex As Exception
        Console.WriteLine("An error occurred: " + ex.Message)
    End Try

    ' Turn on output switch
    ioObj.WriteString(":outp on") '27

    ' Initiate transition and acquire
    ioObj.WriteString(":init (@1)") '30

    Try ' Retrieve measurement result '32
        ioObj.WriteString(":fetc:arr:curr? (@1)")
        s = ioObj.ReadString()

    Catch ex As Exception
        Console.WriteLine("An error occurred: " + ex.Message)
    End Try
End Sub

```

Line	Description
19 to 20	Sets the trigger source to AINT (automatic trigger). And sets the trigger count to 5 to perform a 5-step staircase sweep measurement.
27	Enables the channel. And starts source output (0 V with the default setting).
30	Starts staircase sweep measurement.
32 to 34	Reads the measurement result data.

Pulsed Sweep Measurements

A program example of pulsed sweep measurements is shown in [Table 2-9](#). This example is used to apply pulsed sweep voltage and measure current at each sweep step.

Table 2-8 Pulsed Sweep Measurement Commands

Function	Command
Selects source function	<code>[[:SOUR[c]]]:FUNC:MODE <i>v-or-c</i></code>
Sets pulse output	<code>[[:SOUR[c]]]:FUNC[:SHAP] PULS</code>
Sets sweep output	<code>[[:SOUR[c]]]:<i>v-or-c</i>:MODE SWE</code>
Sets output range when starting sweep	<code>[[:SOUR[c]]]:<i>v-or-c</i>:RANG <i>value</i></code>
Sets source output value	<code>[[:SOUR[c]]]:<i>v-or-c</i> <i>value</i></code>
Sets sweep start or stop value	<code>[[:SOUR[c]]]:<i>v-or-c</i>:<STAR STOP> <i>value</i></code>
Sets sweep center or span value	<code>[[:SOUR[c]]]:<i>v-or-c</i>:<CENT SPAN> <i>value</i></code>
Sets sweep step value	<code>[[:SOUR[c]]]:<i>v-or-c</i>:STEP <i>value</i></code>
Sets number of sweep steps	<code>[[:SOUR[c]]]:<i>v-or-c</i>:POIN <i>value</i></code> <code>[[:SOUR[c]]]:SWE:POIN <i>value</i></code>
Sets pulse delay time	<code>[[:SOUR[c]]]:PULS:DEL <i>time</i></code>
Sets pulse width	<code>[[:SOUR[c]]]:PULS:WIDT <i>time</i></code>
Selects sweep source ranging mode	<code>[[:SOUR[c]]]:SWE:RANG <BEST FIX AUTO></code>
Selects sweep direction	<code>[[:SOUR[c]]]:SWE:DIR <UP DOWN></code>
Selects sweep linear or log	<code>[[:SOUR[c]]]:SWE:SPAC <LIN LOG></code>
Selects sweep single or double	<code>[[:SOUR[c]]]:SWE:STA <SING DOUB></code>
Sets measurement function	<code>:SENS[c]:FUNC "<i>func</i>", "<i>func</i>", "<i>func</i>"</code>

Function	Command
Sets measurement range	:SENS[c]:func:RANG:AUTO <ON OFF> :SENS[c]:func:RANG <i>value</i>
Sets aperture time in seconds or by using NPLC value	:SENS[c]:func:APER <i>time</i> :SENS[c]:func:NPLC <i>value</i>
Sets limit (compliance) value	:SENS[c]:v-or-c:PROT <i>value</i>
Selects trigger source	:TRIG[c]<:ACQ :TRAN [:ALL]>:SOUR <i>source</i>
Sets interval of timer trigger	:TRIG[c]<:ACQ :TRAN [:ALL]>:TIM <i>time</i>
Sets trigger count	:TRIG[c]<:ACQ :TRAN [:ALL]>:COUN <i>value</i>
Sets trigger delay time	:TRIG[c]<:ACQ :TRAN [:ALL]>:DEL <i>time</i>
Enables or disables channel	:OUTP[c] <ON OFF>
Initiates specified action	:INIT<:ACQ :TRAN [:ALL]> [<i>chanlist</i>]
Reads result data (array data)	:FETC:ARR? [<i>chanlist</i>] :FETC:ARR: <i>type</i> ? [<i>chanlist</i>]

v-or-c is VOLT for voltage source or limit (compliance), or CURR for current source or limit (compliance).

func is VOLT for voltage measurement, CURR for current measurement, or RES for resistance measurement.

source is AINT for the automatic trigger, BUS for the remote interface trigger command, TIM for the internal timer, INT n for a signal from the internal bus ($n = 1$ or 2), EXT m for a signal from the GPIO pin m ($m = 1$ to 14), or LAN for the LXI trigger.

type is VOLT for voltage data, CURR for current data, RES for resistance data, SOUR for source output data, STAT for status data, or TIME for time data.

chanlist is (@1) for selecting the channel 1 only, (@2) for selecting the channel 2 only, or (@1,2), (@1:2), (@2,1), or (@2:1) for selecting both channels 1 and 2. Abbreviating this parameter sets *chanlist* = (@1) for the 1-channel models, and *chanlist* = (@1,2) for the 2-channel models.

Table 2-9 Pulsed Sweep Measurement Example

<pre> Sub B2900control(ByVal ioObj As Ivi.Visa.Interop.FormattedIO488, ByRef s As String, ByRef filename As String) filename = "C:/temp/StaircasePulsedSweep1.txt" '2 ioObj.WriteString("*RST") ' Reset Try ' Set voltage output from 0 V to 0.1 V, 5 steps '6 ioObj.WriteString(":sour:func:mode volt") ioObj.WriteString(":sour:func:shap puls") ioObj.WriteString(":sour:volt:mode swe") ioObj.WriteString(":sour:volt:star 0") ioObj.WriteString(":sour:volt:stop 0.1") ioObj.WriteString(":sour:volt:poin 5") ' Set base voltage to 0.0 ioObj.WriteString(":sour:volt 0") ' Set delay/width to 500 us/1 ms ioObj.WriteString(":sour:puls:del 0.5e-3") '17 ioObj.WriteString(":sour:puls:widt 1.0e-3") ' Set 100 mA fixed-range current measurement ioObj.WriteString(":sens:func ""curr""") '21 ioObj.WriteString(":sens:curr:rang:auto off") ioObj.WriteString(":sens:curr:rang 100e-3") ioObj.WriteString(":sens:curr:aper 1e-4") ioObj.WriteString(":sens:curr:prot 0.1") ' Adjust trigger timing parameters ioObj.WriteString(":trig:tran:del 1.5e-3") '28 ioObj.WriteString(":trig:acq:del 2.9e-3") </pre>	
Line	Description
2	Defines the file name used for saving the result data.
4	Resets the B2900.
6 to 14	Sets the voltage pulse sweep output function. And sets the sweep output from 0 to 0.1 V in 0.02 V step (5 points). Also sets the pulse base voltage to 0 V.
17 to 18	Sets the pulse delay time and the pulse width.
21 to 25	Sets the current measurement function and the 100 mA fixed range measurement. And sets the aperture time to 0.1 ms and the current limit (compliance) value to 0.1 A.
28 to 29	Sets the transient (source) delay time and the acquire (measurement) delay time.

```

' Generate 5 triggers in 4 ms period
ioObj.WriteString(":trig:sour tim")           ' 32
ioObj.WriteString(":trig:tim 4e-3")
ioObj.WriteString(":trig:coun 5")

Catch ex As Exception
  Console.WriteLine("An error occurred: " + ex.Message)
End Try

' Turn on output switch
ioObj.WriteString(":outp on")                 ' 41

' Initiate transition and acquire
ioObj.WriteString(":init (@1)")               ' 44

Try ' Retrieve measurement result             ' 46
  ioObj.WriteString(":fetc:arr:curr? (@1)")
  s = ioObj.ReadString()

Catch ex As Exception
  Console.WriteLine("An error occurred: " + ex.Message)
End Try
End Sub

```

Line	Description
32 to 34	Sets the timer trigger source. And sets the trigger interval to 4 ms, and the trigger count to 5 to perform a 5-step pulsed sweep measurement.
41	Enables the channel. And starts source output (0 V with the default setting).
44	Starts pulsed sweep measurement.
46 to 48	Reads the measurement result data.

Measurement Result Example **Result:** +1.520000E-05,+7.599400E-03,+1.519220E-02,+2.276880E-02,+3.035860E-02

List Sweep Measurements

A program example of list sweep measurements is shown in [Table 2-11](#). This example is used to apply sweep voltage and measure current at each sweep step.

Table 2-10 List Sweep Measurement Commands

Function	Command
Selects source function	<code>[[:SOUR[c]]:FUNC:MODE <i>v-or-c</i></code>
Sets list sweep output	<code>[[:SOUR[c]]:v-or-c:MODE LIST</code>
Sets source output range	<code>[[:SOUR[c]]:v-or-c:RANG:AUTO <ON OFF></code> <code>[[:SOUR[c]]:v-or-c:RANG <i>value</i></code>
Sets source output value	<code>[[:SOUR[c]]:v-or-c <i>value</i></code>
Sets list sweep output values	<code>[[:SOUR[c]]:LIST:v-or-c <i>values</i></code>
Adds list sweep output values to the end of the present setting	<code>[[:SOUR[c]]:LIST:v-or-c:APP <i>values</i></code>
Specifies the list sweep start point	<code>[[:SOUR[c]]:LIST:v-or-c:STAR <i>start_index</i></code>
Asks the number of sweep points	<code>[[:SOUR[c]]:LIST:v-or-c:POIN?</code>
Sets measurement function	<code>:SENS[c]:FUNC "<i>func</i>", "<i>func</i>", "<i>func</i>"</code>
Sets measurement range	<code>:SENS[c]:<i>func</i>:RANG:AUTO <ON OFF></code> <code>:SENS[c]:<i>func</i>:RANG <i>value</i></code>
Sets aperture time in seconds or by using NPLC value	<code>:SENS[c]:<i>func</i>:APER <i>time</i></code> <code>:SENS[c]:<i>func</i>:NPLC <i>value</i></code>
Sets limit (compliance) value	<code>:SENS[c]:v-or-c:PROT <i>value</i></code>
Selects trigger source	<code>:TRIG[c]<:ACQ :TRAN [:ALL]>:SOUR <i>source</i></code>
Sets interval of timer trigger	<code>:TRIG[c]<:ACQ :TRAN [:ALL]>:TIM <i>time</i></code>

Function	Command
Sets trigger count	:TRIG[c]<:ACQ :TRAN [:ALL]>:COUN <i>value</i>
Sets trigger delay time	:TRIG[c]<:ACQ :TRAN [:ALL]>:DEL <i>time</i>
Enables or disables channel	:OUTP[c] <ON OFF>
Initiates specified action	:INIT<:ACQ :TRAN [:ALL]> [<i>chanlist</i>]
Reads result data (array data)	:FETC:ARR? [<i>chanlist</i>] :FETC:ARR: <i>type</i> ? [<i>chanlist</i>]

v-or-c is VOLT for voltage source or limit (compliance), or CURR for current source or limit (compliance).

func is VOLT for voltage measurement, CURR for current measurement, or RES for resistance measurement.

source is AINT for the automatic trigger, BUS for the remote interface trigger command, TIM for the internal timer, INT n for a signal from the internal bus ($n = 1$ or 2), EXT m for a signal from the GPIO pin m ($m = 1$ to 14), or LAN for the LXI trigger.

type is VOLT for voltage data, CURR for current data, RES for resistance data, SOUR for source output data, STAT for status data, or TIME for time data.

chanlist is (@1) for selecting the channel 1 only, (@2) for selecting the channel 2 only, or (@1,2), (@1:2), (@2,1), or (@2:1) for selecting both channels 1 and 2. Abbreviating this parameter sets *chanlist* = (@1) for the 1-channel models, and *chanlist* = (@1,2) for the 2-channel models.

Table 2-11 List Sweep Measurement Example

```

Sub B2900control(ByVal ioObj As Ivi.Visa.Interop.FormattedIO488, ByRef s As String, ByRef
filename As String)
    filename = "C:/temp/ListSweep1.txt" '2

    ioObj.WriteString("*RST") ' Reset

    Try ' Set voltage output to 0.03, 0.06, and 0.1 V '6
        ioObj.WriteString(":sour:func:mode volt")
        ioObj.WriteString(":sour:volt:mode list")
        ioObj.WriteString(":sour:list:volt 0.03,0.06,0.1")

        ' Set auto-range current measurement
        ioObj.WriteString(":sens:func ""curr""") '12
        ioObj.WriteString(":sens:curr:nplc 0.1")
        ioObj.WriteString(":sens:curr:prot 0.1")

        ' Generate 3 triggers by automatic internal algorithm
        ioObj.WriteString(":trig:sour aint") '17
        ioObj.WriteString(":trig:coun 3")

    Catch ex As Exception
        Console.WriteLine("An error occurred: " + ex.Message)
    End Try

    ' Turn on output switch
    ioObj.WriteString(":outp on") '25

    ' Initiate transition and acquire
    ioObj.WriteString(":init (@1)") '28

    Try ' Retrieve measurement result '30
        ioObj.WriteString(":fetc:arr:curr? (@1)")
        s = ioObj.ReadString()

    Catch ex As Exception
        Console.WriteLine("An error occurred: " + ex.Message)
    End Try
End Sub

```

Line	Description
2	Defines the file name used for saving the result data.
4	Resets the B2900.
6 to 9	Sets the voltage list sweep output function. And sets the list sweep output 0.03 V, 0.06 V, and 0.1 V (3 points).
12 to 14	Sets the current measurement function. And sets the aperture time to 0.1 PLC and the current limit (compliance) value to 0.1 A. Auto range is ON with the default setting.
17 to 18	Sets the trigger source to AINT (automatic trigger). And sets the trigger count to 3 to perform a 3-point list sweep measurement.

```

Sub B2900control(ByVal ioObj As Ivi.Visa.Interop.FormattedIO488, ByRef s As String, ByRef
filename As String)
    filename = "C:/temp/ListSweep1.txt" '2

    ioObj.WriteString("*RST") ' Reset

    Try ' Set voltage output to 0.03, 0.06, and 0.1 V '6
        ioObj.WriteString(":sour:func:mode volt")
        ioObj.WriteString(":sour:volt:mode list")
        ioObj.WriteString(":sour:list:volt 0.03,0.06,0.1")

        ' Set auto-range current measurement
        ioObj.WriteString(":sens:func ""curr""") '12
        ioObj.WriteString(":sens:curr:nplc 0.1")
        ioObj.WriteString(":sens:curr:prot 0.1")

        ' Generate 3 triggers by automatic internal algorithm
        ioObj.WriteString(":trig:sour aint") '17
        ioObj.WriteString(":trig:coun 3")

    Catch ex As Exception
        Console.WriteLine("An error occurred: " + ex.Message)
    End Try

    ' Turn on output switch
    ioObj.WriteString(":outp on") '25

    ' Initiate transition and acquire
    ioObj.WriteString(":init (@1)") '28

    Try ' Retrieve measurement result '30
        ioObj.WriteString(":fetc:arr:curr? (@1)")
        s = ioObj.ReadString()

    Catch ex As Exception
        Console.WriteLine("An error occurred: " + ex.Message)
    End Try
End Sub

```

Line	Description
25	Enables the channel. And starts source output (0 V with the default setting).
28	Starts list sweep measurement.
30 to 32	Reads the measurement result data.

Measurement Result Example Result: +9.121600E-03,+1.822320E-02,+3.036130E-02

Pulsed List Sweep Measurements

A program example of pulsed list sweep measurements is shown in [Table 2-13](#). This example is used to apply pulsed sweep voltage and measure current at each sweep step.

Table 2-12 Pulsed List Sweep Measurement Commands

Function	Command
Selects source function	<code>[[:SOUR[c]]:FUNC:MODE <i>v-or-c</i></code>
Sets pulse output	<code>[[:SOUR[c]]:FUNC[:SHAP] PULS</code>
Sets list sweep output	<code>[[:SOUR[c]]:<i>v-or-c</i>:MODE LIST</code>
Sets source output range	<code>[[:SOUR[c]]:<i>v-or-c</i>:RANG:AUTO <ON OFF></code> <code>[[:SOUR[c]]:<i>v-or-c</i>:RANG <i>value</i></code>
Sets source output value	<code>[[:SOUR[c]]:<i>v-or-c</i> <i>value</i></code>
Sets list sweep output values	<code>[[:SOUR[c]]:LIST:<i>v-or-c</i> <i>values</i></code>
Adds list sweep output values to the end of the present setting	<code>[[:SOUR[c]]:LIST:<i>v-or-c</i>:APP <i>values</i></code>
Specifies the list sweep start point	<code>[[:SOUR[c]]:LIST:<i>v-or-c</i>:STAR <i>start_index</i></code>
Asks the number of sweep points	<code>[[:SOUR[c]]:LIST:<i>v-or-c</i>:POIN?</code>
Sets pulse delay time	<code>[[:SOUR[c]]:PULS:DEL <i>time</i></code>
Sets pulse width	<code>[[:SOUR[c]]:PULS:WIDT <i>time</i></code>
Sets measurement function	<code>:SENS[c]:FUNC "<i>func</i>"[, "<i>func</i>"[, "<i>func</i>"]]</code>
Sets measurement range	<code>:SENS[c]:<i>func</i>:RANG:AUTO <ON OFF></code> <code>:SENS[c]:<i>func</i>:RANG <i>value</i></code>
Sets aperture time in seconds or by using NPLC value	<code>:SENS[c]:<i>func</i>:APER <i>time</i></code> <code>:SENS[c]:<i>func</i>:NPLC <i>value</i></code>

Function	Command
Sets limit (compliance) value	:SENS[c]:v-or-c:PROT <i>value</i>
Selects trigger source	:TRIG[c]<:ACQ :TRAN [:ALL]>:SOUR <i>source</i>
Sets interval of timer trigger	:TRIG[c]<:ACQ :TRAN [:ALL]>:TIM <i>time</i>
Sets trigger count	:TRIG[c]<:ACQ :TRAN [:ALL]>:COUN <i>value</i>
Sets trigger delay time	:TRIG[c]<:ACQ :TRAN [:ALL]>:DEL <i>time</i>
Enables or disables channel	:OUTP[c] <ON OFF>
Initiates specified action	:INIT<:ACQ :TRAN [:ALL]> [<i>chanlist</i>]
Reads result data (array data)	:FETC:ARR? [<i>chanlist</i>]
	:FETC:ARR: <i>type</i> ? [<i>chanlist</i>]

v-or-c is VOLT for voltage source or limit (compliance), or CURR for current source or limit (compliance).

func is VOLT for voltage measurement, CURR for current measurement, or RES for resistance measurement.

source is AINT for the automatic trigger, BUS for the remote interface trigger command, TIM for the internal timer, INT n for a signal from the internal bus ($n = 1$ or 2), EXT m for a signal from the GPIO pin m ($m = 1$ to 14), or LAN for the LXI trigger.

type is VOLT for voltage data, CURR for current data, RES for resistance data, SOUR for source output data, STAT for status data, or TIME for time data.

chanlist is (@1) for selecting the channel 1 only, (@2) for selecting the channel 2 only, or (@1,2), (@1:2), (@2,1), or (@2:1) for selecting both channels 1 and 2. Abbreviating this parameter sets *chanlist* = (@1) for the 1-channel models, and *chanlist* = (@1,2) for the 2-channel models.

Table 2-13 Pulsed List Sweep Measurement Example

<pre> Sub B2900control(ByVal ioObj As Ivi.Visa.Interop.FormattedIO488, ByRef s As String, ByRef filename As String) filename = "C:/temp/ListPulsedSweep1.txt" '2 ioObj.WriteString("*RST") ' Reset Try ' Set voltage output to 0.03, 0.06, and 0.1 V '6 ioObj.WriteString(":sour:func:mode volt") ioObj.WriteString(":sour:func:shap puls") ioObj.WriteString(":sour:volt:mode list") ioObj.WriteString(":sour:list:volt 0.03,0.06,0.1") ' Set base voltage to 0.0 ioObj.WriteString(":sour:volt 0") ' Set delay/width to 500 us/1 ms ioObj.WriteString(":sour:puls:del 0.5e-3") '15 ioObj.WriteString(":sour:puls:widt 1.0e-3") ' Set 100 mA fixed-range current measurement ioObj.WriteString(":sens:func ""curr""") '19 ioObj.WriteString(":sens:curr:rang:auto off") ioObj.WriteString(":sens:curr:rang 100e-3") ioObj.WriteString(":sens:curr:aper 1e-4") ioObj.WriteString(":sens:curr:prot 0.1") ' Adjust trigger timing parameters ioObj.WriteString(":trig:tran:del 1.5e-3") '26 ioObj.WriteString(":trig:acq:del 2.9e-3") </pre>	
Line	Description
2	Defines the file name used for saving the result data.
4	Resets the B2900.
6 to 12	Sets the voltage pulse list sweep output function. And sets the pulsed list sweep output 0.03 V, 0.06 V, and 0.1 V (3 points). Also sets the pulse base voltage to 0 V.
15 to 16	Sets the pulse delay time and the pulse width.
19 to 23	Sets the current measurement function and the 100 mA fixed range measurement. And sets the aperture time to 0.1 ms and the current limit (compliance) value to 0.1 A.
26 to 27	Sets the transient (source) delay time and the acquire (measurement) delay time.

```

' Generate 3 triggers in 4 ms period
ioObj.WriteString(":trig:sour tim")           ' 30
ioObj.WriteString(":trig:tim 4e-3")
ioObj.WriteString(":trig:coun 3")

Catch ex As Exception
  Console.WriteLine("An error occurred: " + ex.Message)
End Try

' Turn on output switch
ioObj.WriteString(":outp on")                 ' 39

' Initiate transition and acquire
ioObj.WriteString(":init (@1)")               ' 42

Try ' Retrieve measurement result             ' 44
  ioObj.WriteString(":fetc:arr:curr? (@1)")
  s = ioObj.ReadString()

Catch ex As Exception
  Console.WriteLine("An error occurred: " + ex.Message)
End Try
End Sub

```

Line	Description
30 to 32	Sets the timer trigger source. And sets the trigger interval to 4 ms, and the trigger count to 3 to perform a 3-point pulsed list sweep measurement.
39	Enables the channel. And starts source output (0 V with the default setting).
42	Starts pulsed list sweep measurement.
44 to 46	Reads the measurement result data.

Measurement Result Example **Result:** +9.123000E-03,+1.822410E-02,+3.036380E-02

Sampling Measurements

A program example of sampling measurements is shown in [Table 2-15](#). This example is used to apply constant voltage and measure current six times.

Table 2-14 Sampling Measurement Commands

Function	Command
Selects source function	<code>[:SOUR[c]]:FUNC:MODE <i>v-or-c</i></code>
Sets source output range	<code>[:SOUR[c]]:v-or-c:RANG:AUTO <ON OFF></code> <code>[:SOUR[c]]:v-or-c:RANG <i>value</i></code>
Sets source output value	<code>[:SOUR[c]]:v-or-c <i>value</i></code>
Sets triggered source output value	<code>[:SOUR[c]]:v-or-c:TRIG <i>value</i></code>
Sets measurement function	<code>:SENS[c]:FUNC "<i>func</i>"[, "<i>func</i>"[, "<i>func</i>"]]</code>
Sets measurement range	<code>:SENS[c]:<i>func</i>:RANG:AUTO <ON OFF></code> <code>:SENS[c]:<i>func</i>:RANG <i>value</i></code>
Sets aperture time in seconds or by using NPLC value	<code>:SENS[c]:<i>func</i>:APER <i>time</i></code> <code>:SENS[c]:<i>func</i>:NPLC <i>value</i></code>
Sets limit (compliance) value	<code>:SENS[c]:v-or-c:PROT <i>value</i></code>
Selects trigger source	<code>:TRIG[c]<:ACQ :TRAN [:ALL]>:SOUR <i>source</i></code>
Sets interval of timer trigger	<code>:TRIG[c]<:ACQ :TRAN [:ALL]>:TIM <i>time</i></code>
Sets trigger count	<code>:TRIG[c]<:ACQ :TRAN [:ALL]>:COUN <i>value</i></code>
Sets trigger delay time	<code>:TRIG[c]<:ACQ :TRAN [:ALL]>:DEL <i>time</i></code>
Enables or disables channel	<code>:OUTP[c] <ON OFF></code>

Function	Command
Initiates specified action	:INIT<:ACQ :TRAN [:ALL]> [<i>chanlist</i>]
Reads result data (array data)	:FETC:ARR? [<i>chanlist</i>]
	:FETC:ARR: <i>type</i> ? [<i>chanlist</i>]

v-or-c is VOLT for voltage source or limit (compliance), or CURR for current source or limit (compliance).

func is VOLT for voltage measurement, CURR for current measurement, or RES for resistance measurement.

source is AINT for the automatic trigger, BUS for the remote interface trigger command, TIM for the internal timer, INT n for a signal from the internal bus ($n = 1$ or 2), EXT m for a signal from the GPIO pin m ($m = 1$ to 14), or LAN for the LXI trigger.

type is VOLT for voltage data, CURR for current data, RES for resistance data, SOUR for source output data, STAT for status data, or TIME for time data.

chanlist is (@1) for selecting the channel 1 only, (@2) for selecting the channel 2 only, or (@1,2), (@1:2), (@2,1), or (@2:1) for selecting both channels 1 and 2. Abbreviating this parameter sets *chanlist* = (@1) for the 1-channel models, and *chanlist* = (@1,2) for the 2-channel models.

Table 2-15 Sampling Measurement Example

```

Sub B2900control(ByVal ioObj As Ivi.Visa.Interop.FormattedIO488, ByRef s As String, ByRef
filename As String)
    filename = "C:/temp/Sampling1.txt" '2

    ioObj.WriteString("*RST") ' Reset

    Try ' Set voltage output '6
        ioObj.WriteString(":sour:func:mode volt")
        ' Set triggered voltage to 0.1 V
        ioObj.WriteString(":sour:volt:trig 0.1")
        ' Set auto-range current measurement
        ioObj.WriteString(":sens:func ""curr""") '11
        ioObj.WriteString(":sens:curr:nplc 0.1")
        ioObj.WriteString(":sens:curr:prot 0.1")
        ' Adjust trigger timing parameters
        ioObj.WriteString(":trig:acq:del 2.0e-3") '15
        ' Generate 6 triggers in 4 ms period
        ioObj.WriteString(":trig:sour tim") '17
        ioObj.WriteString(":trig:tim 4e-3")
        ioObj.WriteString(":trig:coun 6")

    Catch ex As Exception
        Console.WriteLine("An error occurred: " + ex.Message)
    End Try

    ' Turn on output switch
    ioObj.WriteString(":outp on") '26

    ' Initiate transition and acquire
    ioObj.WriteString(":init (@1)") '29

    Try ' Retrieve measurement result '31
        ioObj.WriteString(":fetc:arr:curr? (@1)")
        s = ioObj.ReadString()

    Catch ex As Exception
        Console.WriteLine("An error occurred: " + ex.Message)
    End Try
End Sub

```

Line	Description
2	Defines the file name used for saving the result data.
4	Resets the B2900.
6 to 9	Sets the voltage output function. And sets the bias voltage to 0.1 V.
11 to 13	Sets the current measurement function and the auto range measurement. And sets the aperture time to 0.1 PLC and the current limit (compliance) value to 0.1 A.
15	Sets the acquire (measurement) delay time.

```

Sub B2900control(ByVal ioObj As Ivi.Visa.Interop.FormattedIO488, ByRef s As String, ByRef
filename As String)
    filename = "C:/temp/Sampling1.txt" '2

    ioObj.WriteString("*RST") ' Reset

    Try ' Set voltage output '6
        ioObj.WriteString(":sour:func:mode volt")
        ' Set triggered voltage to 0.1 V
        ioObj.WriteString(":sour:volt:trig 0.1")
        ' Set auto-range current measurement
        ioObj.WriteString(":sens:func ""curr""") '11
        ioObj.WriteString(":sens:curr:nplc 0.1")
        ioObj.WriteString(":sens:curr:prot 0.1")
        ' Adjust trigger timing parameters
        ioObj.WriteString(":trig:acq:del 2.0e-3") '15
        ' Generate 6 triggers in 4 ms period
        ioObj.WriteString(":trig:sour tim") '17
        ioObj.WriteString(":trig:tim 4e-3")
        ioObj.WriteString(":trig:coun 6")

    Catch ex As Exception
        Console.WriteLine("An error occurred: " + ex.Message)
    End Try

    ' Turn on output switch
    ioObj.WriteString(":outp on") '26

    ' Initiate transition and acquire
    ioObj.WriteString(":init (@1)") '29

    Try ' Retrieve measurement result '31
        ioObj.WriteString(":fetc:arr:curr? (@1)")
        s = ioObj.ReadString()

    Catch ex As Exception
        Console.WriteLine("An error occurred: " + ex.Message)
    End Try
End Sub

```

Line	Description
17 to 19	Sets the timer trigger source. And sets the timer interval to 4 ms, and the trigger count to 6 to perform a 6-point sampling measurement.
26	Enables the channel. And starts source output (0 V with the default setting).
29	Starts sampling measurement.
31 to 33	Reads the measurement result data.

Measurement Result Example Result: +3.036250E-02,+3.036240E-02,+3.036190E-02,+3.036210E-02,+3.036300E-02,+3.036270E-02

Pass/Fail Judgment and Math Function

A program example of pass/fail judgments is shown in [Table 2-18](#). This example is used to perform power vs voltage sweep measurement and performs pass/fail judgment. Power is calculated by using the built-in math function.

Table 2-16

Math Function Commands

Function	Command
Specifies math expression	:CALC[c]:MATH:NAME " <i>name</i> "
Defines math expression	:CALC[c]:MATH:DEF <i>definition</i>
Sets unit for the math expression	:CALC[c]:MATH:UNIT
Enables or disables math function	:CALC[c]:MATH:STAT <ON OFF>

Table 2-17

Pass/Fail Judgment Commands

Function	Command
Sets composite limit test mode to grading or sorting	:CALC[c]:CLIM:MODE <GRAD SORT>
Specifies test result output timing for the grading mode, end or immediate	:CALC[c]:CLIM:UPD <END IMM>
Enables or disables composite limit test	:CALC[c]:CLIM:STAT <ON OFF>
Specifies limit test feed data	:CALC[c]:FEED <i>type</i>
Sets compliance check or limit test	:CALC[c]:LIM:FUNC <COMP LIM>
Sets limit test lower or upper limit	:CALC[c]:LIM:<LOW UPP> <i>value</i>
Sets compliance fail condition	:CALC[c]:LIM:COMP:FAIL <OUT IN>
Enables or disables limit test	:CALC[c]:LIM:STAT <ON OFF>
Asks limit test result pass or fail	:CALC[c]:LIM:FAIL?

type is VOLT for voltage measurement data, CURR for current measurement data, RES for resistance measurement data, or MATH for math result data.

Table 2-18 Pass/Fail Judgment Example

```

Sub B2900control(ByVal ioObj As Ivi.Visa.Interop.FormattedIO488, ByRef s As String, ByRef
filename As String)
    filename = "C:/temp/Judgement1.txt" '2

    ioObj.WriteString("*RST") ' Reset

    Try ' Set voltage sweep from 0.0 V to 0.1 V, 201 linear steps '6
        ioObj.WriteString(":sour:func:mode volt")
        ioObj.WriteString(":sour:volt:mode swe")
        ioObj.WriteString(":sour:volt:star 0.0")
        ioObj.WriteString(":sour:volt:stop 0.1")
        ioObj.WriteString(":sour:volt:poin 201")
        ioObj.WriteString(":sour:swe:spac lin")
        ioObj.WriteString(":sour:swe:sta sing")

        ' Set current limit to 100 mA
        ioObj.WriteString(":sens:curr:prot 0.1") '16

        ' Enable predefined math expression power (voltage * current)
        ioObj.WriteString(":calc:math:name ""POWER""") '19
        ioObj.WriteString(":calc:math:stat on")

        ' Set limit test mode to "Grading"
        ioObj.WriteString(":calc:clim:mode grad") '23
        ioObj.WriteString(":calc:clim:upd end")
        ioObj.WriteString(":calc:clim:stat on")

        ' Feed math result and judge it is in +/-5 mW or not
        ioObj.WriteString(":calc:feed math") '28
        ioObj.WriteString(":calc:lim1:stat on")
        ioObj.WriteString(":calc:lim1:func lim")
        ioObj.WriteString(":calc:lim1:low -5.0e-3")
        ioObj.WriteString(":calc:lim1:upp +5.0e-3")
    
```

Line	Description
2	Defines the file name used for saving the result data.
4	Resets the B2900.
6 to 13	Sets the voltage sweep output function. And sets the sweep output from 0 to 0.1 V, 201 points. Also sets the linear increment and single sweep.
16	Sets the current limit (compliance) value to 0.1 A.
19 to 20	Enables POWER math function.
23 to 25	Enables composite limit test of grading mode.
28 to 32	Enables limit test 1 which judges if POWER is between -5 mW and +5 mW.

Programming Examples
Pass/Fail Judgment and Math Function

```

' Set arm count to 1, trigger count to 201
ioObj.WriteString(":arm:coun 1")
ioObj.WriteString(":trig:coun 201")
' 35

Catch ex As Exception
  Console.WriteLine("An error occurred: " + ex.Message)
End Try

' Turn on output switch
ioObj.WriteString(":outp on")
' 43

' Initiate transition and acquire
ioObj.WriteString(":init (@1)")
' 46

' Wait for operation complete
ioObj.WriteString("*OPC?")
' 49
Dim d As String = ioObj.ReadString()
Console.WriteLine("*OPC?: " + d)
Console.WriteLine()

Try ' Retrieve measurement result (not bin numbers)
  ioObj.WriteString(":calc:data?")
  s = ioObj.ReadString()

  ioObj.WriteString(":calc:lim1:fail?")
  d = ioObj.ReadString()
  If d = 0 Then
    Console.WriteLine("PASS")
  Else
    Console.WriteLine("FAIL")
  End If
  Console.WriteLine()
' 54
' 58

Catch ex As Exception
  Console.WriteLine("An error occurred: " + ex.Message)
End Try
End Sub

```

Line	Description
35 to 36	Sets the arm count to 1, and the trigger count to 201 to perform a 201-step staircase sweep measurement.
43	Enables the channel. And starts source output (0 V with the default setting).
46	Starts staircase sweep measurement.
49 to 52	Waits for operation complete. And write “*OPC?: 1” on the console window when the operation is completed.
54 to 56	Reads the measurement result data.
58 to 65	Reads the judgement result. And write “PASS” or “FAIL” on the console window.

Measurement
Result Example

Result: -2.341916E-10,+8.687035E-08,+3.241116E-07,+7.134239E-07,+1.258200E-06,+1.947869E-06,+2.790977E-06,+3.793277E-06,+4.929483E-06,+6.228402E-06,+7.677595E-06,+9.279485E-06,+1.103210E-05,+1.293916E-05,+1.499512E-05,+1.721203E-05,+1.957131E-05,+2.207869E-05,+2.467268E-05,+2.755153E-05,+3.052130E-05,+3.363800E-05,+3.691760E-05,+4.033103E-05,+4.390036E-05,+4.762392E-05,+5.151573E-05,+5.553805E-05,+5.972507E-05,+6.405285E-05,+6.851899E-05,+7.315973E-05,+7.794760E-05,+8.288631E-05,+8.796509E-05,+9.320610E-05,+9.860479E-05,+1.041754E-04,+1.098613E-04,+1.157115E-04,+1.215744E-04,+1.278577E-04,+1.341738E-04,+1.406063E-04,+1.472060E-04,+1.539637E-04,+1.608716E-04,+1.679319E-04,+1.751681E-04,+1.825232E-04,+1.900483E-04,+1.977296E-04,+2.055358E-04,+2.135138E-04,+2.216522E-04,+2.298863E-04,+2.383193E-04,+2.468891E-04,+2.556029E-04,+2.645003E-04,+2.735255E-04,+2.826991E-04,+2.919260E-04,+3.015675E-04,+3.112219E-04,+3.209985E-04,+3.309458E-04,+3.410295E-04,+3.512634E-04,+3.616291E-04,+3.720819E-04,+3.827504E-04,+3.936007E-04,+4.045787E-04,+4.157298E-04,+4.270301E-04,+4.384635E-04,+4.501420E-04,+4.618862E-04,+4.738464E-04,+4.859040E-04,+4.981206E-04,+5.104463E-04,+5.229651E-04,+5.356430E-04,+5.484076E-04,+5.614119E-04,+5.744722E-04,+5.877991E-04,+6.011935E-04,+6.148205E-04,+6.285388E-04,+6.424530E-04,+6.564842E-04,+6.706918E-04,+6.850603E-04,+6.995474E-04,+7.141454E-04,+7.289117E-04,+7.438255E-04,+7.589229E-04,+7.741655E-04,+7.895723E-04,+8.051391E-04,+8.208203E-04,+8.367055E-04,+8.526876E-04,+8.688672E-04,+8.852325E-04,+9.016407E-04,+9.182453E-04,+9.349851E-04,+9.518914E-04,+9.689457E-04,+9.861478E-04,+1.003523E-03,+1.021063E-03,+1.038796E-03,+1.056637E-03,+1.074605E-03,+1.092708E-03,+1.110964E-03,+1.129434E-03,+1.147996E-03,+1.166662E-03,+1.185524E-03,+1.204595E-03,+1.223783E-03,+1.243249E-03,+1.262697E-03,+1.282301E-03,+1.302063E-03,+1.321965E-03,+1.342132E-03,+1.362347E-03,+1.382697E-03,+1.403252E-03,+1.424084E-03,+1.444900E-03,+1.465962E-03,+1.487102E-03,+1.508430E-03,+1.529923E-03,+1.551453E-03,+1.573165E-03,+1.595088E-03,+1.617097E-03,+1.639334E-03,+1.661768E-03,+1.684316E-03,+1.707018E-03,+1.729902E-03,+1.752875E-03,+1.776006E-03,+1.799316E-03,+1.822720E-03,+1.846251E-03,+1.869993E-03,+1.893788E-03,+1.917864E-03,+1.941986E-03,+1.966472E-03,+1.990904E-03,+2.015598E-03,+2.040341E-03,+2.065370E-03,+2.090549E-03,+2.115705E-03,+2.141095E-03,+2.166588E-03,+2.192289E-03,+2.218138E-03,+2.244184E-03,+2.270309E-03,+2.296767E-03,+2.323176E-03,+2.349848E-03,+2.376582E-03,+2.403580E-03,+2.430636E-03,+2.457834E-03,+2.485222E-03,+2.512773E-03,+2.540283E-03,+2.568170E-03,+2.596157E-03,+2.624402E-03,+2.652645E-03,+2.681054E-03,+2.709752E-03,+2.738454E-03,+2.767308E-03,+2.796405E-03,+2.825400E-03,+2.854952E-03,+2.884357E-03,+2.914004E-03,+2.943753E-03,+2.973740E-03,+3.003983E-03,+3.034236E-03

Using Program Memory

A program example for using program memory is shown in [Table 2-20](#). This example is used to store a program in the program memory and execute it.

Table 2-19 Program Memory Commands

Function	Command
Returns the names of all programs defined in the program memory	:PROG:CAT?
Specifies memory program	:PROG:NAME "name"
Defines memory program ^a	:PROG:DEF <i>program_code</i>
Adds program code to the end of the memory program ^a	:PROG:APP <i>program_code</i>
Sets a value to the variable specified by <i>n</i> ^b	:PROG:VAR <i>n</i> "value"
Executes memory program ^a	:PROG:EXEC
Changes status of memory program ^a	:PROG:STAT <i>operation</i>
Blocks other commands until the program execution status changes to Paused or Stopped ^a	:PROG:WAIT? <i>timeout_in_seconds</i>
Deletes a memory program ^a	:PROG:DEL
Deletes all memory programs	:PROG:DEL:ALL

a. This function is effective for the memory program previously specified by the :PROG:NAME command.

b. Variables can be used in the memory program. They must be expressed as %*n*% (*n*: integer. 1 to 100) in the memory program.

operation is RUN to change to the running status, PAUS to change to the paused status, CONT to change to the running status, STOP to change to the stopped status, or STEP to perform step execution.

Table 2-20 Example to Use Program Memory

<pre> Sub B2900control(ByVal ioObj As Ivi.Visa.Interop.FormattedIO488, ByRef s As String, ByRef filename As String) filename = "C:/temp/ProgramMemory1.txt" '2 ioObj.WriteString("*RST") ' Reset Try ' Build program '6 Dim program As String = "" program = ":sour:func:mode curr\n" program += ":sour:curr:mode swe\n" program += ":sour:curr:star 0.0\n" program += ":sour:curr:stop 40e-3\n" program += ":sour:curr:poin 21\n" program += ":sens:func ""volt""\n" program += ":sens:curr:nplc 0.1\n" program += ":arm:coun 1\n" program += ":trig:coun 21\n" program += ":outp 1\n" program += ":init (@1)\n" ' Get program length Dim sProgramLength As String = String.Format("{0:#}", program.Length) '21 ioObj.WriteString(":prog:name ""sample""") '23 ioObj.WriteString(":prog:def #" + sProgramLength.Length.ToString() + sProgramLength + program) Catch ex As Exception Console.WriteLine("An error occurred: " + ex.Message) End Try </pre>	
Line	Description
2	Defines the file name used for saving the result data.
4	Resets the B2900.
6 to 18	Enters program code to the "program" variable. The program is for performing current source voltage measure sweep measurement from 0 A to 40 mA, 21 points, with the aperture time 0.1 PLC.
21	Gets the program length (number of characters in the "program" variable).
23 to 24	Stores the program code to the program memory as the program name "sample".

Programming Examples
Using Program Memory

<pre>' Run program ioObj.WriteString(":prog:stat run") ' Wait for operation complete ioObj.WriteString("*OPC?") s = ioObj.ReadString() Console.Write("*OPC?: " + s) Console.WriteLine() Try ' Retrieve measurement result ioObj.WriteString(":fetch:arr:volt? (@1)") s = ioObj.ReadString() Catch ex As Exception Console.WriteLine("An error occurred: " + ex.Message) End Try End Sub</pre>	<p>' 31</p> <p>' 34</p> <p>' 39</p>
Line	Description
31	Executes the memory program.
34 to 37	Waits for operation complete. And write "*OPC?: 1" on the console window when the operation is completed.
39 to 41	Reads the measurement result data.

**Measurement
Result Example**

Result: -7.480000E-05,+6.524500E-03,+1.311680E-02,+1.971080E-02,+2.630190E-02,+3.289570E-02,+3.948990E-02,+4.607940E-02,+5.266580E-02,+5.926410E-02,+6.585490E-02,+7.244700E-02,+7.903250E-02,+8.562770E-02,+9.221940E-02,+9.880730E-02,+1.053949E-01,+1.119873E-01,+1.185849E-01,+1.251736E-01,+1.317632E-01

Reading Binary Data

A program example for reading binary data is shown in [Table 2-22](#). This example is used to read data in the ASCII format and the 8-byte binary format.

For performing a staircase sweep measurement, replace the program code from lines 32 to 38 shown in [Table 2-7](#) with the code shown in [Table 2-22](#).

Table 2-21 Data Output Format Commands

Function	Command
Sets the data output format	:FORM[:DATA] <i>format</i>
Sets byte order of binary data	:FORM:BORD <i>byte_order</i>

format is ASC for the ASCII data output format, REAL,32 for the IEEE-754 single precision format (4-byte data), or REAL,64 for the IEEE-754 double precision format (8-byte data).

byte_order is NORM for the normal byte order from byte 1 to byte 4 or 8, or SWAP for the reverse byte order from byte 4 or 8 to byte 1.

**Measurement
 Result Example**

Result: V (V), I (A), Time (sec), Status: -5.88E-05,2.85297E-06,0.021938,21
 120.0222637,0.006749,0.030997,36480.0499995,0.0151897,0.037096,41600.075000
 8,0.022776,0.041071,41600.0999998,0.0303624,0.045048,4160

Table 2-22 Example to Read Binary Data

```

' Select measure data elements                                     '2
ioObj.WriteString(":form:elem:sens volt,curr,time,stat")

' Retrieve measurement result & Output measurement result(Ascii format) '4
ioObj.WriteString(":form asc")
ioObj.WriteString(":fetch:arr? (@1)")
Dim numOfElem As Integer = 4 'V, I, Time, Status
Dim data(numOfElem * trigCount - 1)
data = ioObj.ReadList(Ivi.Visa.Interop.IEEEASCIIType.ASCIIType_Any, ",")

Dim value As String = "V (V), I (A), Time (sec), Status: "
s = value
Console.WriteLine("ASCII format")
Console.WriteLine(value)
For i = LBound(data) To UBound(data)
    If (i + 1) Mod numOfElem = 0 Then
        Console.WriteLine(data(i).ToString())
        s = s + data(i).ToString()
    Else
        Console.Write(data(i).ToString() + ",")
        s = s + data(i).ToString() + ","
    End If
Next
Console.WriteLine()

' Retrieve measurement result & Output measurement result(Real64 format) '27
Console.WriteLine("REAL64 format")
Console.WriteLine(value)
ioObj.WriteString(":form real,64")
ioObj.WriteString(":fetch:arr? (@1)")
Dim data64
data64 = ioObj.ReadIEEEBlock(Ivi.Visa.Interop.IEEEBinaryType.BinaryType_R8, False, True)
For i = LBound(data64) To UBound(data64)
    If (i + 1) Mod numOfElem = 0 Then
        Console.WriteLine(data64(i).ToString())
    Else
        Console.Write(data64(i).ToString() + ",")
    End If
Next
Console.WriteLine()

```

Line	Description
2	Specifies the data to return. This example selects voltage measurement data, current measurement data, time data, and status data.
4 to 23	Reads the measurement result data in the ASCII format.
27 to 40	Reads the measurement result data in the REAL,64 format.

Performing MOSFET Id-Vd Measurements

Table 2-24 shows a programming example for measuring MOSFET Id-Vd characteristics. This example uses two channels.

The channel 1 performs the primary sweep output to apply the drain voltage, and measures the drain current at each sweep step.

The channel 2 performs the secondary sweep output to apply the gate voltage. The secondary sweep is realized by using the list sweep function.

Table 2-23 Channel Connections to the Device

Channel	Terminal	Connection
1	High Force	MOSFET drain terminal
	High Sense	
	Low Force	MOSFET source and substrate terminals
	Low Sense	
2	High Force	MOSFET gate terminal
	High Sense	
	Low Force	MOSFET source and substrate terminals
	Low Sense	

Measurement Result Example

Result:
 $-2.102110E-06, +1.149380E-03, +1.827990E-03, +2.150970E-03, +2.272340E-03, +2.313980E-03, +2.333310E-03, +2.346400E-03, +2.356810E-03, +2.365510E-03, +2.373160E-03, -1.332470E-05, +2.465270E-03, +4.501590E-03, +6.113420E-03, +7.326210E-03, +8.180630E-03, +8.736170E-03, +9.073850E-03, +9.283210E-03, +9.427320E-03, +9.536790E-03, -2.731010E-05, +3.513460E-03, +6.642130E-03, +9.363240E-03, +1.167520E-02, +1.359510E-02, +1.513140E-02, +1.631180E-02, +1.717590E-02, +1.778500E-02, +1.821690E-02$

Table 2-24 MOSFET Id-Vd Measurement Example

<pre> Sub B2900control(ByVal ioObj As Ivi.Visa.Interop.FormattedIO488, ByRef s As String, ByRef filename As String) filename = "C:/temp/MOSFETId-Vd1.txt" '2 ioObj.WriteString("*RST") ' Reset Try ' Set primary sweep 0 V to 3 V, 11 points '6 ioObj.WriteString(":sour1:func:mode volt") ioObj.WriteString(":sour1:volt:mode swe") ioObj.WriteString(":sour1:volt:star 0") ioObj.WriteString(":sour1:volt:stop 3") ioObj.WriteString(":sour1:volt:poin 11") ' Set secondary sweep 1 V to 3 V, 3 steps, 33 points Dim vg As String = "" '14 vg = "1,1,1,1,1,1,1,1,1,1,1,1," ' for 1st staircase sweep measurement vg += "2,2,2,2,2,2,2,2,2,2,2,2," ' for 2nd staircase sweep measurement vg += "3,3,3,3,3,3,3,3,3,3,3,3" ' for 3rd staircase sweep measurement ioObj.WriteString(":sour2:func:mode volt") ioObj.WriteString(":sour2:volt:mode list") ioObj.WriteString(":sour2:list:volt " + vg) ' Set auto-range current measurement ioObj.WriteString(":sens1:func ""curr""") '23 ioObj.WriteString(":sens1:curr:nplc 0.1") ioObj.WriteString(":sens1:curr:prot 0.1") ioObj.WriteString(":sens2:curr:prot 0.01") '26 </pre>	
Line	Description
2	Defines the file name used for saving the result data.
4	Resets the B2900.
6 to 11	Sets the channel 1 to the primary sweep source. And sets the sweep output from 0 to 3 V in 0.3 V step (11 points).
14 to 20	Sets the channel 2 to the secondary sweep source. And sets the sweep output from 1 to 3 V in 1 V step (3 steps, 33 points to perform 11-step staircase sweep measurement three times).
23 to 25	Sets the channel 1 measurement function to the current measurement. And sets the aperture time to 0.1 PLC and the current limit (compliance) value to 100 mA. Auto range is ON with the default setting.
26	Sets the channel 2 current limit (compliance) value to 10 mA.

<pre> ' Generate 33 triggers by automatic internal algorithm ioObj.WriteString(":trig1:sour aint") ioObj.WriteString(":trig1:coun 33") ioObj.WriteString(":trig2:sour aint") ioObj.WriteString(":trig2:coun 33") ' 29 Catch ex As Exception Console.WriteLine("An error occurred: " + ex.Message) End Try ' Turn on output switch ioObj.WriteString(":outp1 on") ioObj.WriteString(":outp2 on") ' 39 ' Initiate transition and acquire ioObj.WriteString(":init (@1,2)") ' 43 Try ' Retrieve measurement result ioObj.WriteString(":fetc:arr:curr? (@1)") s = ioObj.ReadString() ' 45 Catch ex As Exception Console.WriteLine("An error occurred: " + ex.Message) End Try End Sub </pre>	
Line	Description
29 to 32	For the channels 1 and 2, sets the trigger source to AINT (automatic trigger). And sets the trigger count to 33 to perform the 11-step staircase sweep measurement three times.
39 to 40	Enables the channels 1 and 2. And starts source output (0 V with the default setting).
43	Starts MOSFET Id-Vd measurement.
45 to 47	Reads the measurement result data.

This information is subject to change without notice.
© Keysight Technologies 2020
Edition 1, December 2020



B2910-90120
www.keysight.com