

# Keysight Technologies E4416A/4417A Power Meters

# Notices

## Copyright Notice

© Keysight Technologies 2001–2021

No part of this manual may be reproduced in any form or by any means (including electronic storage and retrieval or translation into a foreign language) without prior agreement and written consent from Keysight Technologies as governed by United States and international copyright laws.

## Manual Part Number

E4416-90014

## Edition

Edition 15, December 13, 2021

## Printed in:

Printed in Malaysia

## Published by:

Keysight Technologies  
Bayan Lepas Free Industrial Zone,  
11900 Penang, Malaysia

## Technology Licenses

The hardware and/or software described in this document are furnished under a license and may be used or copied only in accordance with the terms of such license.

## Declaration of Conformity

Declarations of Conformity for this product and for other Keysight products may be downloaded from the Web. Go to <http://www.keysight.com/go/conformity>. You can then search by product number to find the latest Declaration of Conformity.

## U.S. Government Rights

The Software is “commercial computer software,” as defined by Federal Acquisition Regulation (“FAR”) 2.101. Pursuant to FAR 12.212 and 27.405-3 and Department of Defense FAR Supplement (“DFARS”) 227.7202, the U.S. government acquires commercial computer software under the same terms by which the software is customarily provided to the public. Accordingly, Keysight provides the Software to U.S. government customers under its standard commercial license, which is embodied in its End User License Agreement (EULA), a copy of which can be found at <http://www.keysight.com/find/sweula>. The license set forth in the EULA represents the exclusive authority by which the U.S. government may use, modify, distribute, or disclose the Software. The EULA and the license set forth therein, does not require or permit, among other things, that Keysight: (1) Furnish technical information related to commercial computer software or commercial computer software documentation that is not customarily provided to the public; or (2) Relinquish to, or otherwise provide, the government rights in excess of these rights customarily provided to the public to use, modify, reproduce, release, perform, display, or disclose commercial computer software or commercial computer software documentation. No additional government requirements beyond those set forth in the EULA shall apply, except to the extent that those terms, rights, or licenses are explicitly required from all providers of commercial computer software pursuant to the FAR and the DFARS and are set forth specifically in writing elsewhere in the EULA. Keysight shall be under no obligation to update, revise or otherwise modify the Software. With respect to any technical data as defined by FAR 2.101, pursuant to FAR 12.211 and 27.404.2 and DFARS 227.7102, the U.S. government acquires no greater than Limited Rights as defined in FAR 27.401 or DFAR 227.7103-5 (c), as applicable in any technical data.

## Warranty

THE MATERIAL CONTAINED IN THIS DOCUMENT IS PROVIDED “AS IS,” AND IS SUBJECT TO BEING CHANGED, WITHOUT NOTICE, IN FUTURE EDITIONS. FURTHER, TO THE MAXIMUM EXTENT PERMITTED BY APPLICABLE LAW, KEYSIGHT DISCLAIMS ALL WARRANTIES, EITHER EXPRESS OR IMPLIED, WITH REGARD TO THIS MANUAL AND ANY INFORMATION CONTAINED HEREIN, INCLUDING BUT NOT LIMITED TO THE IMPLIED WARRANTIES OF MERCHANTABILITY AND FITNESS FOR A PARTICULAR PURPOSE. KEYSIGHT SHALL NOT BE LIABLE FOR ERRORS OR FOR INCIDENTAL OR CONSEQUENTIAL DAMAGES IN CONNECTION WITH THE FURNISHING, USE, OR PERFORMANCE OF THIS DOCUMENT OR OF ANY INFORMATION CONTAINED HEREIN. SHOULD KEYSIGHT AND THE USER HAVE A SEPARATE WRITTEN AGREEMENT WITH WARRANTY TERMS COVERING THE MATERIAL IN THIS DOCUMENT THAT CONFLICT WITH THESE TERMS, THE WARRANTY TERMS IN THE SEPARATE AGREEMENT SHALL CONTROL.

## Safety Information

### CAUTION

A CAUTION notice denotes a hazard. It calls attention to an operating procedure, practice, or the like that, if not correctly performed or adhered to, could result in damage to the product or loss of important data. Do not proceed beyond a CAUTION notice until the indicated conditions are fully understood and met.

### WARNING

A WARNING notice denotes a hazard. It calls attention to an operating procedure, practice, or the like that, if not correctly performed or adhered to, could result in personal injury or death. Do not proceed beyond a WARNING notice until the indicated conditions are fully understood and met.

## Certification

Keysight Technologies certifies that this product met its published specifications at the time of shipment from the factory. Keysight Technologies further certifies that its calibration measurements are traceable to the United States National Institute of Standards and Technology, to the extent allowed by the Institute's calibration facility, and to the calibration facilities of other International Standards Organization members.

## Warranty

This Keysight Technologies instrument product is warranted against defects in material and workmanship for a period of one year from date of shipment. During the warranty period, Keysight Technologies will at its option, either repair or replace products which prove to be defective. For warranty service or repair, this product must be returned to a service facility designated by Keysight Technologies. Buyer shall prepay shipping charges to Keysight Technologies and Keysight Technologies shall pay shipping charges, duties, and taxes for products returned to Keysight Technologies from another country. Keysight Technologies warrants that its software and firmware designated by Keysight Technologies for use with an instrument will execute its programming instructions when properly installed on that instrument. Keysight Technologies does not warrant that the operation of the instrument, or firmware will be uninterrupted or error free.

## Limitation of Warranty

The foregoing warranty shall not apply to defects resulting from improper or inadequate maintenance by Buyer, Buyer-supplied software or interfacing, unauthorized modification or misuse, operation outside of the environmental specifications for the product, or improper site preparation or maintenance. NO OTHER WARRANTY IS EXPRESSED OR IMPLIED. KEYSIGHT TECHNOLOGIES SPECIFICALLY DISCLAIMS THE IMPLIED WARRANTIES OF MERCHANTABILITY AND FITNESS FOR A PARTICULAR PURPOSE.

## Exclusive Remedies

THE REMEDIES PROVIDED HEREIN ARE BUYER'S SOLE AND EXCLUSIVE REMEDIES. KEYSIGHT TECHNOLOGIES SHALL NOT BE LIABLE FOR ANY DIRECT, INDIRECT, SPECIAL, INCIDENTAL, OR CONSEQUENTIAL DAMAGES, WHETHER BASED ON CONTRACT, TORT, OR ANY OTHER LEGAL THEORY.

## Warnings and Cautions

This guide uses warnings and cautions to denote hazards.

### **WARNING**

A warning calls attention to a procedure, practice or the like, which, if not correctly performed or adhered to, could result in injury or the loss of life. Do not proceed beyond a warning until the indicated conditions are fully understood and met.

---





### **CAUTION**

A caution calls attention to a procedure, practice or the like which, if not correctly performed or adhered to, could result in damage to or the destruction of part or all of the equipment. Do not proceed beyond a caution until the indicated conditions are fully understood and met.

---

## Safety Symbols

The following symbol on the instrument and in the documentation indicates precautions that must be taken to maintain safe operation of the instrument.

	<p>Caution, risk of danger.</p> <p>The Instruction Documentation Symbol. The product is marked with this symbol when it is necessary for the user to refer to the instructions in the supplied documentation.</p>
	<p>Alternating current (AC).</p>
	<p>This symbol indicates the operating switch for 'Stand-by' mode. Note, the instrument is NOT isolated from the mains when the switch is pressed.</p> <p>To isolate the instrument, the mains coupler (mains input cord) should be removed from the power supply.</p>
	<p>This symbol indicates the operating switch for 'On' mode).</p>
	<p>External Protective Earth Terminal.</p> <p>While this is a Class I product, provided with a protective earthing conductor in a power cord, an external protective earthing terminal has also been provided. This terminal is for use where the earthing cannot be assured. At least an 18AWG earthing conductor should be used in such an instance, to ground the instrument to an assured earth terminal.</p>

## Personal Safety Considerations

This is a Safety Class I product (provided with a protective earthing ground incorporated in the power cord). The mains plug shall only be inserted in a socket outlet provided with a protective earth contact. Any interruption of the protective conductor, inside or outside the instrument, is likely to make the instrument dangerous. Intentional interruption is prohibited

### **WARNING**

**If this instrument is not used as specified, the protection provided by the equipment could be impaired. This instrument must be used in a normal condition (in which all means of protection are intact) only.**

**No operator serviceable parts inside. Refer servicing to qualified personnel.**

**To prevent electrical shock, do not remove covers.**

**For continued protection against fire hazard, replace the line fuse(s) only with fuses of the same type and rating (for example, normal blow, time delay, etc.). The use of other fuses or material is prohibited.**

---

## General Safety Considerations

### **WARNING**

**Before this instrument is switched on, make sure it has been properly grounded through the protective conductor of the ac power cable to a socket outlet provided with protective earth contact.**

**Any interruption of the protective (grounding) conductor, inside or outside the instrument, or disconnection of the protective earth terminal can result in personal injury.**

---

### **CAUTION**

**Any adjustments or service procedures that require operation of the instrument with protective covers removed should be performed only by trained service personnel.**

---

## Regulatory Markings

	The CE mark shows that the product complies with all the relevant European legal Directives (if accompanied by a year, it signifies when the design was proven).
<b>ICES/NMB-001</b>	This ISM device complies with Canadian ICES-001. Cet appareil ISM est conforme à la norme NMB-001 du Canada.
<b>ISM</b> GROUP 1 CLASS A	This is the symbol of an Industrial Scientific and Medical Group 1 Class A product.
	The CSA mark is a registered trademark of the Canadian Standards Association.

## IEC 1010-1 Compliance

This instrument has been designed and tested in accordance with IEC Publication 1010-1 +A1:1992 Safety Requirements for Electrical Equipment for Measurement, Control and Laboratory Use and has been supplied in a safe condition. The instruction documentation contains information and warnings which must be followed by the user to ensure safe operation and to maintain the instrument in a safe condition.

## Recommended Calibration Interval

Keysight Technologies recommends a two-year calibration cycle for the E4416A and E4417A power meter.



## Sales and Service Offices

By Internet, phone, or fax, get assistance with all your test and measurement needs.

### NOTE

In any correspondence or telephone conversations, refer to the power sensor by its model number and full serial number. With this information, the Keysight Technologies representative can quickly determine whether your unit is still within its warranty period.

### Online assistance

Visit Keysight worldwide Web at: <http://www.keysight.com/find/assist>

Country	Phone Number	Fax Number
United States	800 829 4444	800 829 4433
Canada	877 894 4414	800 746 4866
China	800 810 0189	800 820 2816
Europe	31 20 547 2111	-
Japan	(81) 426 56 7832	(81) 426 56 7840
Korea	(080) 769 0800	(080) 769 0900
Latin America	(305) 269 7500	-
Taiwan	0800 047 866	0800 286 331
Other Asia Pacific Countries:	(65) 6375 8100	(65) 6755 0042

## Returning Your Power Meter for Service

Use the information in this section if you need to return your power meter to Keysight Technologies.

### Package the Power Meter for Shipment

Use the following steps to package the power meter for shipment to Keysight Technologies for service:

1. Fill in a blue service tag (available at the end of this guide) and attach it to the power meter. Please be as specific as possible about the nature of the problem. Send a copy of any or all of the following information:
  - Any error messages that appeared on the power meter display.
  - Any information on the performance of the power meter.

#### CAUTION

**Power meter damage can result from using packaging materials other than those specified. Never use styrene pellets in any shape as packaging materials. They do not adequately cushion the power meter or prevent it from shifting in the carton. Styrene pellets cause power meter damage by generating static electricity and by lodging in the rear panel.**

---

2. Use the original packaging materials or a strong shipping container that is made of double-walled, corrugated cardboard with 159 kg (350 lb) bursting strength. The carton must be both large enough and strong enough to accommodate the power meter and allow at least 3 to 4 inches on all sides of the power meter for packing material.

3. Surround the power meter with at least 3 to 4 inches of packing material, or enough to prevent the power meter from moving in the carton. If packing foam is not available, the best alternative is SD-240 Air Cap™ from Sealed Air Corporation (Commerce, CA 90001). Air Cap looks like a plastic sheet covered with 1-1/4 inch air filled bubbles. Use the pink Air Cap to reduce static electricity. Wrap the power meter several times in the material to both protect the power meter and prevent it from moving in the carton.
4. Seal the shipping container securely with strong nylon adhesive tape.
5. Mark the shipping container "FRAGILE, HANDLE WITH CARE" to ensure careful handling.
6. Retain copies of all shipping papers.

## About this Guide

- 1 Characteristics and Specifications** This chapter lists the power meter's specifications and describes how to interpret these specifications.
- 2 Performance Tests** This chapter contains procedures which allow you to test the power meter's electrical performance to its specifications.
- 3 Adjustments** This chapter contains checks and adjustments that ensure proper performance of the power meter.
- 4 Theory of Operation** This chapter describes how each of the power meter's individual assemblies operate.
- 5 Replaceable Parts** This chapter details the power meter's replaceable parts. It also explains how to assemble and disassemble the power meter.
- 6 Troubleshooting** This chapter contains troubleshooting flow charts designed to isolate faults in the Rmt I/O, GPIB and RS232/422 interface ports.
- A Keysight 432A Power Meters & 478A Sensors: Additional Information** This appendix contains additional information for Keysight 432A power meters and 478A sensors.
- B Equipment Required For Performance Tests And Adjustments** This appendix lists equipment required for performance tests and adjustments.
- C Measurement Uncertainty Analysis - Power Reference Level Test** This appendix contains information on the Measurement Uncertainty Analysis in Power Reference Level Test
- D Measurement Uncertainty Analysis - Instrument Accuracy Test** This appendix contains information on the Measurement Uncertainty Analysis in Instrument Accuracy Test

# Table of Contents

Certification	3
Warranty	3
Limitation of Warranty	4
Exclusive Remedies	4
Warnings and Cautions	4
Safety Symbols	5
Personal Safety Considerations	6
General Safety Considerations	6
Regulatory Markings	7
IEC 1010-1 Compliance	8
Recommended Calibration Interval	8
Sales and Service Offices	9
Returning Your Power Meter for Service	10
Package the Power Meter for Shipment	10
About this Guide	12
<b>1 Characteristics and Specifications</b>	
<b>2 Performance Tests</b>	
Introduction	26
Equipment Required	26
Performance Test Record	27
Calibration Cycle	27
Test Procedures	27
Thermistor Mount Option	27
Zero Test	28
Specification	28
Description	28
Equipment	28
Test Setup	29

Procedure	29
Instrument Accuracy (Normal Path) Test	31
Specification	31
Description	31
Equipment	32
Test Setup	32
Procedure	33
Instrument Accuracy (Average Path) Test	38
Specification	38
Description	38
Test Procedure 1	38
Equipment	38
Test Setup	39
Procedure	39
Test Procedure 2	42
Equipment	42
Test Setup	43
Procedure	43
Power Reference Level Test	47
Description	47
Equipment	49
Test Setup	49
Procedure	49
Keysight E-Series Power Sensor Interface Test	52
Description	52
Equipment	52
Procedure	52
Keysight E932x Power Sensor (Average Path) Functional Test	53
Description	53
Equipment	53
Test Setup	53
Procedure	53
Time Base Accuracy Test	58
Specification	58

Description	58
Equipment	58
Test Setup	58
Procedure	59
Output Standing Wave Ratio (SWR) Test	60
Specification	60
Description	60
Equipment	62
Test Setup	62
Procedure	62
Performance Test Record	68

### 3 Adjustments

Introduction	72
Safety Considerations	72
Equipment Required	72
Post-Repair Adjustments	73
Power Reference Oscillator Frequency Adjustment	74
Description	74
Equipment	74
Procedure	75
Power Reference Oscillator Level Adjustment	77
Description	77
Equipment	79
Procedure	80
Measurement Uncertainty	82
Display Brightness and Contrast Adjustment	83
Introduction	83
Procedure	83

### 4 Theory of Operation

Introduction	86
A1 Power Supply	87
A2 Processor Assembly	88

A3 Front Panel Assembly	91
A4 Comms Assembly	92
A5 Daughter Assembly	93
A6 Measurement Assembly	94
Average Path Operation	94
Normal Path	95
Ancillary Functions	97
Functional Block Diagram	98
<b>5 Replaceable Parts</b>	
Introduction	102
Assembly Part Numbers	103
Front Panel Connector Repair	105
Firmware Upgrades	106
Assembly and Disassembly Guidelines	107
Removing the Power Meter Cover	107
Removing the A1 Power Supply Assembly	108
Removing the A2 Processor Assembly	109
Removing the A4 Comms Assembly	111
Removing the A5 Daughter or A6 Measurement Assemblies	113
Removing the A7 Fan Assembly	114
Removing the Power Meter RAM Battery (BT1)	115
Removing the A3 Front Panel Assembly	116
Replacing the Front Panel Power Reference Cable Assembly	120
Replacing the Rear Panel Power Sensor Cable Assemblies (Options 002 and 003)	122
Replacing the Rear Panel Power Reference Cable Assembly (Option 003)	124
Replacing the Rear Panel Recorder Output(s) Cable Assembly	125
Replacing The Chassis Assembly	126
<b>6 Troubleshooting</b>	
Introduction	128
Suggested Diagnostic Equipment	128



<b>A</b>	<b>Keysight 432A Power Meters &amp; 478A Sensors: Additional Information</b>	
	Keysight 432A Power Meters: Additional Information	140
	Keysight 478A Sensors: Additional Information	141
<b>B</b>	<b>Equipment Required For Performance Tests And Adjustments</b>	
	Summary Table	144
<b>C</b>	<b>Measurement Uncertainty Analysis - Power Reference Level Test</b>	
	Measurement Introduction	148
	Define the Measurand	148
	Define the Measurement Equation	148
	Uncertainty Equation	151
	Voltage Measurements Uncertainty	151
	Mismatch	153
	Calibration factor	154
	Sensor Calibration Factor Drift	155
	Resistance	155
	Repeatability	156
	Sensitivity Coefficients (Ci)	158
	Combined Standard Uncertainty (uc(y))	160
	Expanded Uncertainty	160
<b>D</b>	<b>Measurement Uncertainty Analysis - Instrument Accuracy Test</b>	
	Measurement Introduction	162
	Uncertainties	163
	Define the Measurand	163
	Define the Measurement Equation	163
	Sensitivity Coefficients Ci:	170
	Combined Standard Uncertainty uc(y):	170
	Expanded Uncertainty kuc(y):	172

THIS PAGE HAS BEEN INTENTIONALLY LEFT BLANK.

## List of Figures

Figure 2-1	Zero Test Setup	29
Figure 2-2	Instrument Accuracy (Normal Path) Test Setup	32
Figure 2-3	Test Setup With Attenuator Connected	35
Figure 2-4	Instrument Accuracy (Average Path) Test Setup	39
Figure 2-5	Instrument Accuracy (Average Path) Test Setup	43
Figure 2-6	Power Reference Level Test Setup	49
Figure 2-7	Sensor (Average Path) Functional Test Setup	54
Figure 2-8	Sensor (Average Path) Functional Test Setup With Attenuator	55
Figure 2-9	Time Base Accuracy Test Setup	58
Figure 2-10	Output Standing Wave Ratio Test Setup	62
Figure 3-1	Adjustment Setup	74
Figure 3-2	A2L9 Adjustment Location	76
Figure 3-3	Adjustment Setup	78
Figure 3-4	A2R90 Adjustment Location	82
Figure 6-1	Troubleshooting Guide - TTL Output 1	130
Figure 6-2	Troubleshooting Guide - TTL Output 1 (continued)	131
Figure 6-3	Troubleshooting Guide - TTL Output 2	132
Figure 6-4	Troubleshooting Guide - TTL Output 2 (continued)	133
Figure 6-5	Troubleshooting Guide - TTL Inputs	134
Figure 6-6	Troubleshooting Guide - TTL Inputs (continued)	135
Figure 6-7	Troubleshooting Guide - TTL Inputs (continued)	136
Figure 6-8	Troubleshooting Guide - RS232/422 Interface	137
Figure C-1	Measurement Setup	149
Figure D-1	Measurement Setup	162

THIS PAGE HAS BEEN INTENTIONALLY LEFT BLANK.

## List of Tables

Table 2-1	Zero Test Results	30
Table 2-2	Instrument Accuracy (Normal Path) Test: Results Table	36
Table 2-3	Instrument Accuracy Results (For Indication Only)	41
Table 2-4	Instrument Accuracy Results	46
Table 2-5	Power Reference Level Test Result	51
Table 2-6	Functional Test (Average Path) Results	57
Table 2-7	Power Reference Level Test Result	59
Table 2-8	Output SWR Result	67
Table 2-9	Performance Test Record	68
Table 3-1	Post Repair Adjustments, Tests, and Checks	73
Table B-1	Equipment Required For Performance Tests And Adjustments	144
Table C-1	Measurement Repeatability Results	156
Table C-2	Combined Standard Uncertainty	160
Table D-1	Standard Uncertainty Results	165
Table D-2	Voltage Correction Multiplier	168
Table D-3	Combined Standard Uncertainty	171

THIS PAGE HAS BEEN INTENTIONALLY LEFT BLANK.

# 1 Characteristics and Specifications

For the characteristics and specifications of the E4416A/E4417A Power Meters, refer to the datasheet at <http://literature.cdn.keysight.com/litweb/pdf/5980-1469E.pdf>.

THIS PAGE HAS BEEN INTENTIONALLY LEFT BLANK.



## 2 Performance Tests

Introduction	26
Zero Test	28
Instrument Accuracy (Normal Path) Test	31
Instrument Accuracy (Average Path) Test	38
Power Reference Level Test	47
Keysight E-Series Power Sensor Interface Test	52
Keysight E932x Power Sensor (Average Path) Functional Test	53
Time Base Accuracy Test	58
Output Standing Wave Ratio (SWR) Test	60
Performance Test Record	68

## Introduction

The performance tests described in this chapter test the power meter's electrical performance against the specifications detailed in chapter 1. They are used for incoming inspection, the calibration cycle (also called periodic maintenance), or after repairs have been made.

### NOTE

The following conditions must be met for valid performance tests:

- The power meter and test equipment must have a 30 minute warm-up for all specifications.
- The line voltage for the power meter must be 85 to 264 Vac and the line frequency must be 50 to 440 Hz.
- The ambient temperature must be 0 °C to 55 °C.

---

The following performance tests are described in this chapter:

- Instrument accuracy (normal path) test.
- Instrument accuracy (average path) test.
- Power reference level test.
- Keysight E-Series power sensor interface test.
- Keysight E932x power sensor (average path) functional test.
- Time base accuracy test.
- Output standing wave ratio (SWR) test.

## Equipment Required

Each performance test description details the equipment required by the test. In addition, [Appendix B](#) summarizes the equipment required for all performance tests and adjustments.

## Performance Test Record

Performance test results can be recorded in [Table 2-9, “Performance Test Record”](#) on page 68. The Performance Test Record table lists the performance test specifications and the acceptable limits for each specification.

## Calibration Cycle

Keysight E4416A and E4417A power meters require performance tests to be run every two years to verify that they are operating within specified tolerances. Under conditions of heavy usage or severe operating environments, this calibration cycle should be performed more frequently.

## Test Procedures

It is assumed that the person performing the tests understands how to operate the specified test equipment. Equipment settings, other than those for the power meter, are stated in general terms. It is assumed that the person will select the proper cables, adapters, and probes required for test setups illustrated in this chapter.

## Thermistor Mount Option

The following thermistor mount options are offered:

- 478A Option H75 with VRC at 200  $\Omega$  only (reflection and correction data provided).
- 478A Option H76 with VRC at 200  $\Omega$  only (reflection and correction data provided).
- 478A Option H77 with VRC at 100 and 200  $\Omega$  (reflection and correction data at 50 MHz only).

## Zero Test

### Specification

Electrical Characteristics	Performance Limits
Accuracy: Zero set (Digital settability of zero)	$\pm 50$ nW <sup>[a]</sup>

[a] This performance limit is determined by the zero set specification of the power sensor used in the measurement plus the measurement noise. The range calibrator has a zero set specification of  $\pm 0.50$  nW. The calibrator measurement noise specification is 110 nW at 16 averages. At 512 averages a noise multiplier of 0.24 is required, giving a measurement noise specification of 0.0264 mW (0.24x512).

### Description

After the power meter is initially calibrated and zeroed, the change in the digital readout is monitored. This test also takes drift and noise into account, since drift, noise and zero readings cannot be separated.

### Equipment

- Range Calibrator: Keysight 11683A
- Power Sensor Cable: Keysight 11730A

## Test Setup

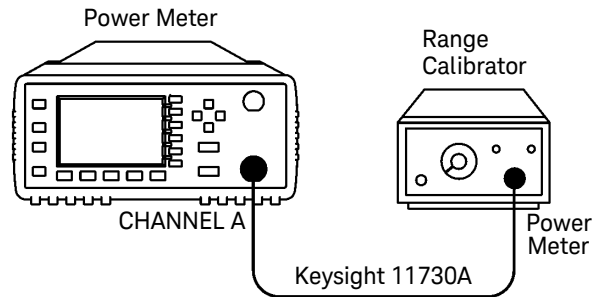

**Figure 2-1** Zero Test Setup

## Procedure

The following procedure should be performed for the Zero Test.

### NOTE

The procedure details the key presses required on the Keysight Technologies E4416A. For the Keysight Technologies E4417A, the equivalent key presses should be performed on both channels.

- 1 Connect the equipment as shown in [Figure 2-1](#).
- 2 Switch the power meter on.
- 3 Press **Preset Local** then **Confirm**.
- 4 Press **Meas Display**, **Units**, **W** for a reading in watts.
- 5 Set the range calibrator as follows:
  - RANGE: 3  $\mu$ W
  - POLARITY: NORMAL
  - FUNCTION: STANDBY
  - LINE: ON

**NOTE**

When switching the range calibrator to STANDBY, allow enough time for the range calibrator to settle to its zero value before attempting to zero the power meter. This settling would appear on the power meter display as downward drift. When the drift has reached minimum, (typically less than 60 seconds), the range calibrator is settled.

**6** Set the filter length:

- Press **Channel** .
- Highlight the **Filter** parameter using the up/down arrow keys.
- Scroll through the **Filter** values by pressing **Change** . Select a value of MAN.
- Highlight the filter length using the forward arrow key. Press **Change** . The Filter Length pop-up window is displayed. Set the filter length to 512.
- Press **Enter** .

**7** Zero the power meter:

Press  , **Zero** . Wait approximately 10 seconds for the wait symbol to disappear.

**8** Wait 30 seconds then verify that the power meter's reading is within  $\pm 50$  nW. Record the reading.**Table 2-1** Zero Test Results

Min	Channel A Actual Results	Channel B Actual Results (E4417A Only)	Max
-50 nW	_____	_____	+50 nW

## Instrument Accuracy (Normal Path) Test

### Specification

Electrical Characteristics	Performance Limits (maximum)
Accuracy	0.8% or 0.04 dB

### Description

This test verifies the accuracy of the normal path in the power meter by calculating linear error over 50 samples. The standard deviation is then calculated using the non-biased or n-1 method:

#### Equation 2-1: Standard Deviation

$$\sigma = \sqrt{\frac{n\sum x^2 - (\sum x)^2}{n(n-1)}}$$

The test result is obtained by applying a factor of K = 2.58:

#### Equation 2-2: Accuracy

$$Accuracy = 2.58\sigma$$

This accuracy figure represents electrical performance of the normal path with confidence limits of 99%.

## Equipment

- Power sensor: Keysight E9321A.
- 2 x Power sensor cable: Keysight E9288A.
- 30 dB reference attenuator: Keysight 11708A.
- Digital voltmeter (DVM): Keysight 3458A.
- Breakout box kit: Keysight E9288AZ-K01 (comprises a breakout box (coupler) and a pair of interconnecting red/black leads).

## Test Setup

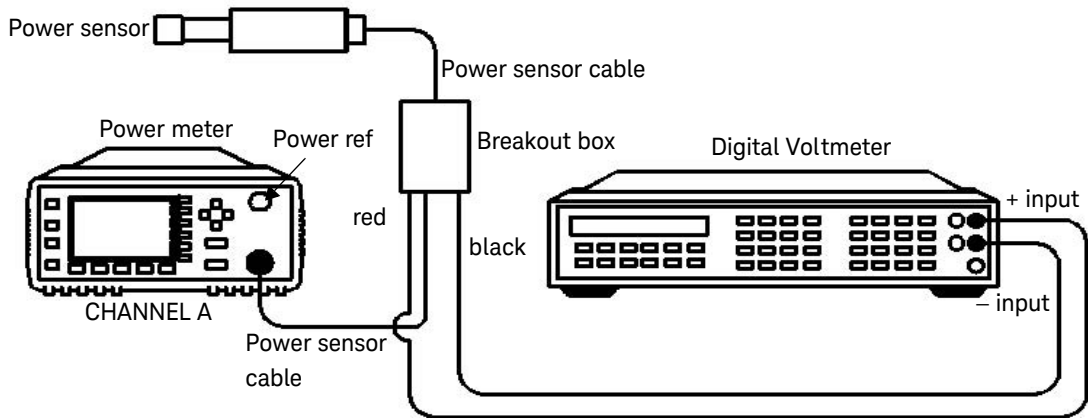

**Figure 2-2** Instrument Accuracy (Normal Path) Test Setup







## Procedure

Use the following procedure to perform the instrument accuracy (normal path) test:

### NOTE

The procedure details the key presses required on the Keysight E4416A. For the Keysight E4417A the equivalent key presses should be performed on both channels.

Connect the equipment as shown in [Figure 2-2](#).



- 1 Switch the power meter on.
- 2 Preset the instrument:
- 3 Press  then **Confirm**.
- 4 Zero the power meter:  
Press , **Zero**. Wait approximately 25 seconds for the wait symbol to disappear.
- 5 Reset the digital voltmeter:  
On the DVM press Shift (the blue key below the DVM display window), to reset the instrument.
- 6 Remove any offset errors introduced by the DVM and the breakout box kit with no power applied:
  - On the DVM press Shift, Auto Zero.
  - Press  five times. The word "math" is shown on the DVM display window.
  - Press  once.
  - Press  eight times. The words "math null" are shown on the DVM display window.
  - Press Enter to complete the key sequence.

7 Turn on the power reference:



- Press  , **Power Ref On**

8 Connect the E9321A sensor to the power reference.

9 Calibrate the system:

- For the E4416A press  , **Cal**
- For the E4417A press  , **Cal** , **Cal A**

10 Provide a point of reference against which the power meter can base its measurements:

- Setup: press  ,  , **Service** , **Self Test** ,  , **Fast Path Accuracy** , **Ref Volts at 0.0 dBm**
- Entry: read the value shown on the DVM display. Set the reference voltage on the pop-up window on the power meter to this value and press **Enter** . This value provides a point of reference that allows the power meter and DVM measurements to be compared at varying power levels.

**NOTE**

When operating the power meter in this test mode, the range of power levels that can be applied is +3 dBm to –30 dBm. Power levels outside this range may cause inaccurate results to be obtained and in some cases may cause damage to the E9321A sensor.

11 Connect the 30 dB reference attenuator as shown in [Figure 2-3](#):

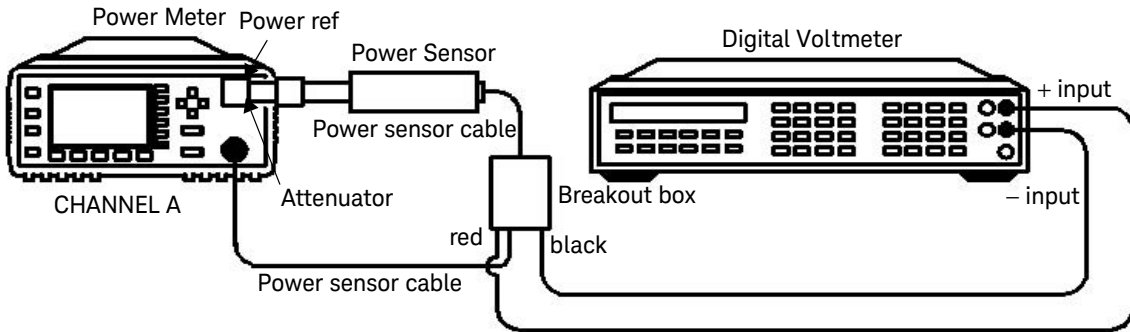

**Figure 2-3** Test Setup With Attenuator Connected

12 Take a measurement:

Wait 30 seconds to allow the power level to settle, then press **Measure** on the power meter.

13 Record the values displayed on both the power meter and DVM displays. Note down the values in [Table 2-2](#).

**NOTE**

These values tend to drift. They must therefore be recorded simultaneously or with as small a delay as possible between them.

14 Repeat step 13 a further 49 times to obtain a set of 50 pairs of measured values.

15 Calculate the measurement error for each pair of measured values using the following equation:

$$x = \left( \frac{(DVMValue - PowerMeterValue)}{DVMValue} \right) \times 100\%$$

Note down each x value in the Error Value (x) column of [Table 2-2](#).

- 16** Calculate the linear standard deviation of the data using [Equation 2-1: Standard Deviation](#), where n = number of samples (50) and x = calculated error values (listed in the Error Value (x) column of [Table 2-2](#))
- 17** Calculate the result of the linear accuracy test using [Equation 2-2: Accuracy](#). Enter the result into [Table 2-9, "Performance Test Record"](#) on page 27, ensuring that the value is within its published specification.

**Table 2-2 Instrument Accuracy (Normal Path) Test: Results Table**

Sample Number	Power Meter Value	DVM Value	Error Value (x)	Sample Number	Power Meter Value	DVM Value	Error Value (x)
1	_____	_____	_____	26	_____	_____	_____
2	_____	_____	_____	27	_____	_____	_____
3	_____	_____	_____	28	_____	_____	_____
4	_____	_____	_____	29	_____	_____	_____
5	_____	_____	_____	30	_____	_____	_____
6	_____	_____	_____	31	_____	_____	_____
7	_____	_____	_____	32	_____	_____	_____
8	_____	_____	_____	33	_____	_____	_____
9	_____	_____	_____	34	_____	_____	_____
10	_____	_____	_____	35	_____	_____	_____
11	_____	_____	_____	36	_____	_____	_____
12	_____	_____	_____	37	_____	_____	_____
13	_____	_____	_____	38	_____	_____	_____
14	_____	_____	_____	39	_____	_____	_____
15	_____	_____	_____	40	_____	_____	_____
16	_____	_____	_____	41	_____	_____	_____
17	_____	_____	_____	42	_____	_____	_____
18	_____	_____	_____	43	_____	_____	_____

**Table 2-2** Instrument Accuracy (Normal Path) Test: Results Table (continued)

Sample Number	Power Meter Value	DVM Value	Error Value (x)	Sample Number	Power Meter Value	DVM Value	Error Value (x)
19	_____	_____	_____	44	_____	_____	_____
20	_____	_____	_____	45	_____	_____	_____
21	_____	_____	_____	46	_____	_____	_____
22	_____	_____	_____	47	_____	_____	_____
23	_____	_____	_____	48	_____	_____	_____
24	_____	_____	_____	49	_____	_____	_____
25	_____	_____	_____	50	_____	_____	_____

## Instrument Accuracy (Average Path) Test

### Specification

Electrical Characteristics	Performance Limits (maximum)
Accuracy	$\pm 0.5\%$ or 0.02 dB <sup>[a]</sup>

[a] This performance limit does not include the corresponding sensor power linearity specification.

### Description

The power meter accuracy is verified for various power inputs. There are two different methods described in this section that can be used to perform this test. One of these methods has a higher measurement uncertainty value associated with it.

### Test Procedure 1

#### NOTE

The measurement uncertainty of this test procedure is relatively high at power levels of 30  $\mu\text{W}$  and below, as it uses a standard 11683A Range Calibrator. As such, this test procedure should be used for indication only.

### Equipment

- Range calibrator: Keysight 11683A.
- Power sensor cable: Keysight E9288A.

## Test Setup

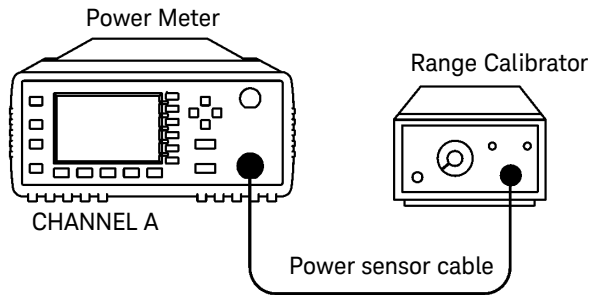

**Figure 2-4** Instrument Accuracy (Average Path) Test Setup

## Procedure

Use the following procedure to perform the instrument accuracy (average path) test:

### NOTE

The procedure details the key presses required on the Keysight E4416A. For the Keysight E4417A the equivalent key presses should be performed on both channels.

- 1 Connect the equipment as shown in [Figure 2-4](#).
- 2 Switch the power meter on.
- 3 Preset the instrument:

Press  then **Confirm**.

- 4 Set the display units to watts:

Press , **Units**, **W**.

**5** Set the display resolution:

Press , then press **Resolution** until **4** is selected.

**6** Set the range calibrator as follows:

- RANGE: 3  $\mu$ W
- POLARITY: NORMAL
- FUNCTION: STANDBY
- LINE: ON

**NOTE**

When switching the range calibrator to STANDBY, allow enough time for the range calibrator to settle to its zero value before attempting to zero the power meter. This settling would appear on the power meter display as downward drift. When the drift has reached minimum, (typically less than 60 seconds), the range calibrator is settled.

---

**7** Set the filter length:

- Press **Channel**.
- Highlight the **Filter** parameter using the up/down arrow keys.
- Scroll through the **Filter** values by pressing **Change**. Select a value of MAN.
- Highlight the filter length using the forward arrow key. Press **Change**. The Filter Length pop-up window is displayed. Set the filter length to 512.
- Press **Enter**.

**8** Zero the power meter:

Press , **Zero**. Wait approximately 10 seconds for the wait symbol to disappear.

**9** Set the range calibrator's FUNCTION switch to CALIBRATE.

**10** Set the range calibrator's RANGE switch to 1 mW.



11 Calibrate the power meter:

Press  , **Cal**

12 Set the range calibrator's RANGE switch to the positions shown in [Table 2-3](#). For each setting, verify that the power meter's reading is within the limits shown.

**Table 2-3** Instrument Accuracy Results (For Indication Only)

Range Calibrator Setting	Min <sup>[a]</sup>	Max <sup>[a]</sup>	Channel A Actual Results	Channel B Actual Results (E4417A Only)
3 $\mu$ W	3.100 $\mu$ W	3.230 $\mu$ W	_____	_____
10 $\mu$ W	9.900 $\mu$ W	10.10 $\mu$ W	_____	_____
30 $\mu$ W	31.40 $\mu$ W	31.80 $\mu$ W	_____	_____
100 $\mu$ W	99.50 $\mu$ W	100.5 $\mu$ W	_____	_____
300 $\mu$ W	314.40 $\mu$ W	317.60 $\mu$ W	_____	_____
1 mW	0.995 mW	1.005 mW	_____	_____
3 mW	3.141 mW	3.171 mW	_____	_____
10 mW	9.984 mW	10.08 mW	_____	_____
30 mW	31.63 mW	31.94 mW	_____	_____
100 mW	100.9 mW	101.8 mW	_____	_____

[a] These performance limits are determined by the zero set specification of the power sensor used in the measurement plus the measurement noise.

**NOTE**

The nominal outputs for the 3  $\mu$ W, 30  $\mu$ W, 300  $\mu$ W, 3 mW, 10 mW, 30 mW and 100 mW settings are 3.16  $\mu$ W, 31.6  $\mu$ W, 100  $\mu$ W, 316  $\mu$ W, 3.156 mW, 10.034 mW, 31.785 mW, and 101.35 mW respectively.

It is not necessary to check instrument accuracy in dBm. The power meter uses the same internal circuitry to measure power and mathematically converts watts to dBm.

## Test Procedure 2

### NOTE

This test procedure makes use of a 11683A Range Calibrator fitted with Option H01. The measurement uncertainty of this test procedure is significantly lower than the previously described method (refer to Appendix D, [Measurement Uncertainty Analysis - Instrument Accuracy Test](#) for a description of the measurement uncertainty analysis). As such, this test procedure should be used to ensure the power meter meets its published specification.

---

### Equipment

- Range Calibrator: Keysight 11683A Option H01
- Power Sensor Cable: Keysight E9288A
- DC Calibrator: Datron 4000A

## Test Setup

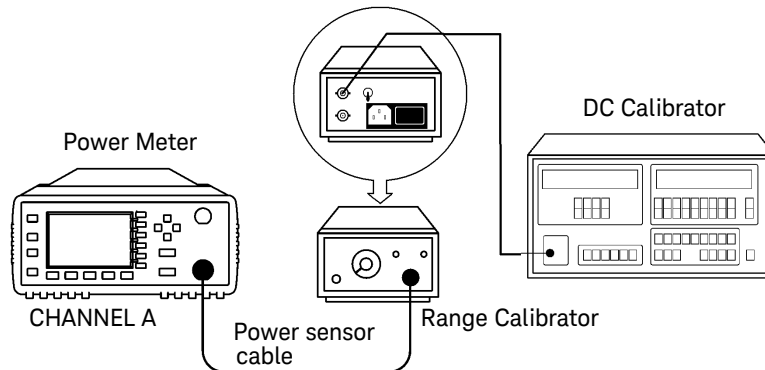

**Figure 2-5** Instrument Accuracy (Average Path) Test Setup

## Procedure

### NOTE



The following procedure should be performed for the Instrument Accuracy Test. The procedure details the key presses required on the Keysight E4416A. For the Keysight E4417A the equivalent key presses should be performed on both channels.

- 1 Connect the equipment as shown in [Figure 2-5](#).
- 2 Unplug the range calibrator's power cord. Due to a ground loop design problem with the 11683A Option H01 range calibrator, it does not operate properly unless ground loops are eliminated. The range calibrator continues to operate with no power applied, and disconnecting the power cord eliminates the problem.

**WARNING**

**There is a small risk of mild electrical shock from the chassis of the 11683A Option H01 range calibrator unless the power meter is connected.**

---

- 3 **Figure 2-5** shows the HI/LO outputs of the DC calibrator connected to the DC reference input of the range calibrator. Ensure that the Guard and LO output of the DC calibrator are floating, and are not connected to the earth ground.
- 4 Switch the power meter on.
- 5 Preset the instrument:  
Press  then **Confirm**.
- 6 Set the display units to watts:  
Press , **Units**, **W**.
- 7 Set the display resolution:  
Press , then press **Resolution** until **4** is selected.
- 8 Set the range calibrator as follows:
  - RANGE: 100 mW
  - POLARITY: NORMAL
  - FUNCTION: STANDBY
  - REF SWITCH: EXT
  - LINE: OFF

**NOTE**

When switching the range calibrator to STANDBY, allow enough time for the range calibrator to settle to its zero value before attempting to zero the power meter. This settling would appear on the power meter display as downward drift. When the drift has reached minimum, (typically less than 60 seconds), the range calibrator is settled.

---

**9** Set the DC calibrator as follows:

- SET VALUE: 0 (ZERO)
- FUNCTION: DC
- OUTPUT: OFF

**10** Set the filter length:

- Press **Channel** .
- Highlight the **Filter** parameter using the up/down arrow keys.
- Scroll through the **Filter** values by pressing **Change** . Select a value of MAN.
- Highlight the filter length using the forward arrow key. Press **Change** . The Filter Length pop-up window is displayed. Set the filter length to 512.
- Press **Enter** .

**11** Zero the power meter:

Press  , **Zero** . Wait approximately 10 seconds for the wait symbol to disappear.

**12** Set the DC calibrator output to 144.93 mV, and set the output switch to '+'.

**13** Calibrate the power meter:

Press  , **Cal** .

**14** Set the DC calibrator output to the values shown in [Table 2-4](#). For each setting, set the filter length of the power meter to the carbon-dating value, and verify that the power meter reading is within the limits shown. Refer to step 10 for details on how to setup the filter length.

**Table 2-4** Instrument Accuracy Results

DC Calibrator Setting	Effective Power Applied	Power Meter Filter Setting	Meas Unc	Lower Limit	Ch A Result	Ch B Result	Upper Limit	GuardBand Lower Limit (in $\mu\text{W}$ )	GuardBand Upper Limit (in $\mu\text{W}$ )
458.31 $\mu\text{V}$	3.1623 $\mu\text{W}$	256	0.028 $\mu\text{W}$	3.0977 $\mu\text{W}$	_____	_____	3.2269 $\mu\text{W}$	3.1257	3.1989
1.4493 mV	10 $\mu\text{W}$	256	0.027 $\mu\text{W}$	9.904 $\mu\text{W}$	_____	_____	10.096 $\mu\text{W}$	9.931	10.069
4.5831 mV	31.6228 $\mu\text{W}$	256	0.027 $\mu\text{W}$	31.428 $\mu\text{W}$	_____	_____	31.819 $\mu\text{W}$	31.455	31.792
14.493 mV	100 $\mu\text{W}$	64	0.073 $\mu\text{W}$	99.49 $\mu\text{W}$	_____	_____	100.51 $\mu\text{W}$	99.563	100.437
45.831 mV	316.2278 $\mu\text{W}$	64	0.104 $\mu\text{W}$	314.72 $\mu\text{W}$	_____	_____	317.74 $\mu\text{W}$	314.824	317.636
144.93 mV	1 mW	16	0.2 $\mu\text{W}$	0.9954 mW	_____	_____	1.0047 mW	995.6	1004.5
459.12 mV	3.1623 mW	16	0.9 $\mu\text{W}$	3.1477 mW	_____	_____	3.1769 mW	3148.6	3176
1.4588 V	10 mW	16	1.6 $\mu\text{W}$	9.954 mW	_____	_____	10.046 mW	995.6	10044.4
4.6872 V	31.6228 mW	16	4.8 $\mu\text{W}$	31.477 mW	_____	_____	31.769 mW	31481.8	31764.2
15.588 V	100 mW	16	18.5 $\mu\text{W}$	99.54 mW	_____	_____	100.46 mW	99558.5	100441.5

## Power Reference Level Test

Electrical Characteristics	Performance Limits (maximum)	Conditions
Power reference	1 mW	Internal 50 MHz oscillator factory set to $\pm 0.4\%$ traceable to National Physical Laboratory (NPL), UK.
Power reference accuracy setting	$\pm 0.1\%$	Guardbanded Test Line Limits.
Power reference accuracy after 2 years	$\pm 0.9\%$ (0 to 55 °C)	Worst case power meter accuracy, taking into account the possibility of oscillator drift and operation at 55 °.

### Description

This test verifies the power level accuracy of the internal 50 MHz oscillator—also called the power reference oscillator. The power reference oscillator output is factory adjusted to 1 mW  $\pm 0.4\%$ . This accuracy includes a performance limit of 0.1% and a system measurement uncertainty figure of 0.3% (traceable to the National Physical Laboratory (NPL), UK). Refer to [Appendix C](#) for the measurement uncertainty of the system.

#### NOTE

The setting of the oscillator output accuracy is determined from the system measurement uncertainty plus any chosen test line limit.

For example, if a test line limit of 1 mW  $\pm 0.2\%$  was chosen while maintaining a system measurement uncertainty of  $\pm 0.3\%$ , the overall accuracy of the test setup for the 1 mW power output becomes 0.3% + 0.2%, giving a setting accuracy of 0.5%.

If an equivalent measurement system is employed for post-factory test (with ambient temperature of 23  $\pm 3$  °C), the power reference oscillator output can again be set to 1 mW  $\pm 0.4\%$ . This setting is sufficient to ensure that the power reference oscillator meets the accuracy specification of  $\pm 0.5\%$  after 2 years. This specification includes the  $\pm 0.4\%$  setting and also takes into account other factors that will contribute to determining the accuracy after 2 years. The complete breakdown of the  $\pm 0.5\%$  specification is as follows:

- Test line limit: 0.1%.
- System uncertainty: 0.3%.
- 2 year oscillator drift: 0.04%.
- Delta environment: <0.06%.

The same equipment used to measure the accuracy of the power reference oscillator can also be used to set it to the post-factory accuracy of ±0.4% (for further information refer to [Chapter 3, "Adjustments"](#)).

The following procedure ensures maximum accuracy in measuring power reference oscillator output using Keysight test instruments of known capability. Signal acquisition criteria may vary if alternative test instruments are used. In such cases refer to the manufacturer's guidelines for further information.

The test is performed using Equation 2-4:

**Equation 2-4: Power Level Provided By The Reference Oscillator**

$$P_{meas} = \frac{2V_{comp}(V_1 - V_0) + V_0^2 - V_1^2}{4R(CalibrationFactor)}$$

The components of this equation are defined as follows:

- $V_0$  is the voltage measured between  $V_{comp}$  and  $V_{RF}$  with no power applied and after the Keysight 432A has been zeroed.
- $V_1$  is the voltage measured between  $V_{comp}$  and  $V_{RF}$  with power applied. This power is approximately 1 mW.
- $V_{comp}$  is the voltage between the Keysight 432A  $V_{comp}$  connector and chassis ground with power applied.
- $R$  is the resistance of the mount resistor in the Keysight 432A power meter. For further information refer to [Appendix A](#).
- Calibration Factor is the value of the thermistor mount at 50 MHz.



## Equipment

- Test power meter: Keysight 432A.
- Thermistor mount: Keysight 478A Option H75 or H76.
- Digital voltmeter (DVM): Keysight 3458A.

## Test Setup

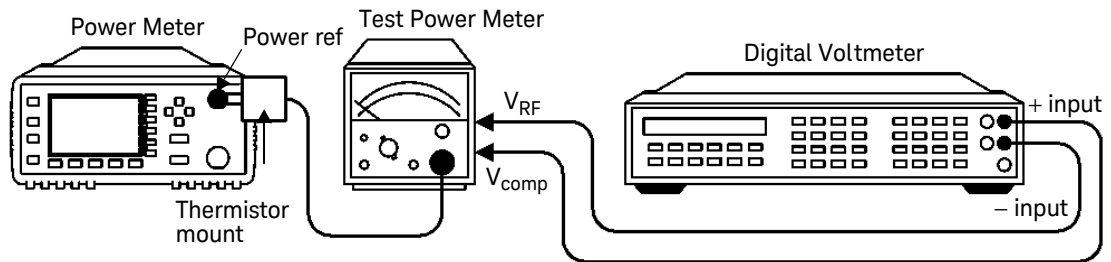

**Figure 2-6** Power Reference Level Test Setup

## Procedure

Use the following procedure to perform the power reference level test:

### NOTE

The procedure details the key presses required on the Keysight E4416A. For the Keysight E4417A the equivalent key presses should be performed on both channels.

- 1 Set the DVM to measure resistance:

Connect the DVM between the  $V_{RF}$  connector on the rear panel of the Keysight 432A and pin 1 on the thermistor mount end of the sensor cable. Verify that no power is applied to the Keysight 432A.

- 2 Round off the DVM reading to two decimal places and note this value as the internal bridge resistance (R) of the Keysight 432A (approximately 200  $\Omega$ ).
  - R \_\_\_\_\_  $\Omega$
- 3 Connect the equipment as shown in [Figure 2-6](#), ensuring that the DVM input leads are isolated from chassis ground.

**NOTE**

Ensure that the Keysight 432A and the power meter under test have been powered on for at least 30 minutes before moving to step 4.

- 4 Preset the power meter:

Press , then **Confirm** on the power meter.

Set the Keysight 432A RANGE switch to Coarse Zero. Adjust the front panel Coarse Zero control to obtain a zero meter indication.

- 5 Zero the Keysight 432A test power meter:
  - Fine zero the Keysight 432A on the most sensitive range.
  - Set the RANGE switch to 1 mW.
- 6 Set the DVM to measure microvolts.
- 7 Connect the positive and negative input leads to the  $V_{\text{comp}}$  and  $V_{\text{RF}}$  connectors respectively, on the rear panel of the test power meter.
- 8 Observe the reading on the DVM. If less than 400  $\mu\text{V}$ , proceed to the next step. If 400  $\mu\text{V}$  or greater, press and hold the test power meter Fine Zero switch and adjust the Coarse Zero control so that the DVM indicates 200  $\mu\text{V}$  or less. Release the Fine Zero switch and proceed to the next step.
- 9 Round the DVM reading to two decimal places.  
Record this reading as  $V_0$ .
  - $V_0$  \_\_\_\_\_
- 10 Turn the power reference on:

Press , **Power Ref On**.

- 11** Round the DVM reading to two decimal places.  
Record this reading as  $V_1$ .
- $V_1$  \_\_\_\_\_
- 12** Disconnect the DVM negative input lead from the VRF connector on the Keysight 432A. Reconnect it to the Keysight 432A chassis ground.
- 13** Observe the DVM reading. Record the reading as  $V_{\text{comp}}$ .
- $V_{\text{comp}}$  \_\_\_\_\_
- 14** Calculate the Power Reference Oscillator power using equation 2-4.
- 15** Verify that  $P_{\text{meas}}$  is within the limits shown in [Table 2-5](#) and record the reading in the table.

**Table 2-5** Power Reference Level Test Result

Min	Max	Actual Result
0.991 mW	1.009 mW	_____

## Keysight E-Series Power Sensor Interface Test

### Description

Keysight E-Series power sensors have sensor calibration tables stored in EEPROM. This enables the power meter to download frequency and calibration factor data automatically. The frequency and calibration factor data have checksums which are compared to the data downloaded by the power meter. For the Keysight E4417A dual channel power meter, this test must be performed on both channels.

This test verifies that the power meter can successfully download this data from the sensor.

### Equipment

- Power sensor cable: Keysight E9288A.
- Power sensor: Keysight E9321A.

### Procedure

- 1 Connect the E9321A power sensor to the power meter's Channel A input. The following message appears:
  - For the Keysight E4416A: Reading Sensor.
  - For the Keysight E4417A: Reading Sensor ChA.

When all data has been downloaded this message disappears and a reading is displayed on the measurement window. If the download fails, a warning message and error flag are displayed on the front panel. The SCPI error message **-310, System Error** is also displayed.

#### NOTE

When no power sensor is connected to the Channel A input, the following message is displayed on the measurement window:

- For the Keysight E4416A: No Sensor.
- For the Keysight E4417A: No Sensor ChA.

- 
- 2 For the Keysight E4417A repeat step 1 for Channel B.

# Keysight E932x Power Sensor (Average Path) Functional Test

## Description

This test verifies that the meter/sensor combination can make average path RF measurements in both upper and lower power ranges.

Keysight E-Series power sensors operate over a wide dynamic range: the value is sensor dependent and ranges from  $-70$  dBm to  $+44$  dBm. However as there is an amplifier in these power sensors, the voltages presented to the power sensor connector are always within the range of voltages available from the Keysight 11683A range calibrator.

## Equipment

- Power sensor cable: Keysight E9288A.
- Reference attenuator: Keysight 11708A.
- Power sensor: Keysight E9321A.

## Test Setup

Refer to [Figure 2-7](#) and [Figure 2-8](#) below.

## Procedure

Use the following procedure to perform the test:

**NOTE**

The procedure details the key presses required on the Keysight E4416A. For the Keysight E4417A the equivalent key presses must be performed on both channels.

---

- 1 Connect the equipment as shown in [Figure 2-7](#).

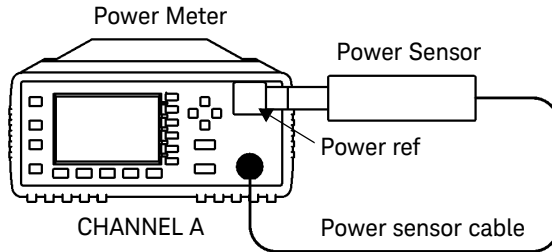

**Figure 2-7** Sensor (Average Path) Functional Test Setup

- 2 Preset the instrument:

Press **Preset Local** then **Confirm**.

- 3 Set the sensor mode to AVG only:

Press **Channel**.

- Highlight the Sensor Mode parameter using the up/down arrow keys.
- Press **Change**.
- A pop-up window is displayed.
- Scroll through the Sensor Mode values using the up/down arrow keys. Select a value of AVG only.
- Press **Enter**.
- Press **Done**.

4 Zero the instrument:

Press **Zero/Cat**, **Zero**. Wait approximately 25 seconds for the wait symbol to disappear.

5 Press **Cal** to calibrate the power meter.

6 Connect the 30 dB attenuator as shown in [Figure 2-8](#).

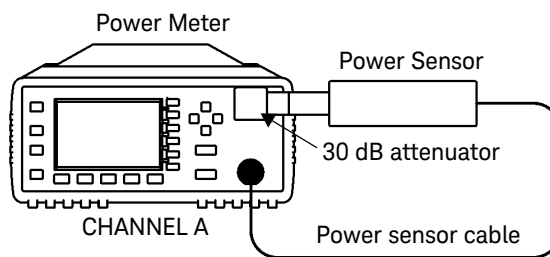

**Figure 2-8** Sensor (Average Path) Functional Test Setup With Attenuator

7 Turn on the power reference:

Press **Zero/Cat**, **Power Ref On**.

8 Switch to the power sensor's lower range:

- Press **Channel**.
- Scroll through the Range values by pressing **Change**. Select a value of LOWER.
- A pop-up window is displayed.
- Press **Done**.

9 Verify that the display reads  $-30 \text{ dBm} \pm 1 \text{ dB}$ . Record the reading in [Table 2-6](#).

**10** Switch to the power sensor's upper range:

- Press **Channel** .
- Move to the Range parameter using the up/down arrow keys.
- Scroll through the Range values by pressing **Change** . Select a value of UPPER.
- Press **Done** .

**11** Verify that the display reads  $-30 \text{ dBm} \pm 1 \text{ dB}$ . Record the reading in [Table 2-6](#).

**12** Turn on the power reference:

Press  , **Power Ref Off**

**13** Switch to the power sensor's lower range:

- Press **Channel** .
- Move to the Range parameter using the up/down arrow keys.
- Scroll through the Range values by pressing **Change** . Select a value of LOWER.
- Press **Done** .

**14** Disconnect the 30 dB attenuator and reconnect the test setup as shown in [Figure 2-7](#).

**15** Turn on the power reference:

Press  , **Power Ref On**

**16** Verify that an overload error is displayed on the status line at the top of the power meter's display and that the display reads 999.99 dBm.



**17** Switch to the power sensor's upper range:

- Press **Channel** .
- Move to the Range parameter using the up/down arrow keys.
- Scroll through the Range values by pressing **Change** . Select a value of UPPER.
- Press **Done** .

**18** Verify that the display reads 0 dBm  $\pm$ 1 dB. Record the reading.

**Table 2-6** Functional Test (Average Path) Results

Test	Channel A Results	Channel B Results (Keysight E4417A Only)
Low Range, 30 dB pad	_____	_____
Upper Range, 30 dB pad	_____	_____
Low Range, no pad	_____	_____
High Range, no pad	_____	_____

## Time Base Accuracy Test

### Specification

Electrical Characteristics	Performance Limits
Frequency accuracy	10 MHz $\pm$ 0.01%

### Description

This test measures the accuracy of the power meter's time base frequency. Time base frequency determines the accuracy of the sampling rate when making measurements. Time base frequency is measured by attaching a frequency counter to the Trig Out socket on the rear of the power meter then enabling test mode from the service menu.

### Equipment

- Frequency counter: Keysight 53132A.

### Test Setup

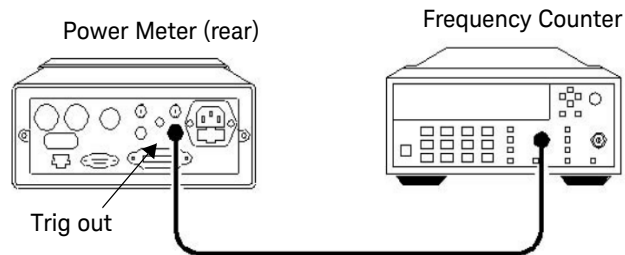

**Figure 2-9** Time Base Accuracy Test Setup



## Procedure

Use the following procedure to perform the test:

- 1 Connect the equipment as shown in [Figure 2-9](#).
- 2 Switch on the power meter.
- 3 Preset the instrument:

Press  then **Confirm**.

- 4 Enable time base test mode:

Press , , **Service**, **Self Test**, ,  
**Time Base**, **Enable 10 MHz TB**

- 5 Note the reading on the frequency counter and verify that it is within the limits shown in [Table 2-7](#):

**Table 2-7** Power Reference Level Test Result

Min	Max	Actual Result
9.9990 MHz	10.0010 MHz	_____

## Output Standing Wave Ratio (SWR) Test

### Specification

Electrical Characteristics	Performance Limits (maximum)
Output SWR	1.06 <sup>[a]</sup> 1.08 <sup>[b]</sup>

[a] For instruments with the 50 MHz 1mW output (power ref) connector mounted on the front panel.

[b] For instruments with the 50 MHz 1mW output (power ref) connector mounted on the rear panel. This applies to models E4416A and E4417A with Option 003 fitted.

### Description

This test measures the standing wave ratio (SWR) of the 50 MHz 1 mW output (power ref) connector on the power meter to verify that it is within its published specification.

When RF power is transferred from a source to a load, the level of power absorbed by the load,  $P_A$ , is dependent on the respective impedance of the load and the effective output impedance of the source. This can be expressed in terms of the voltage reflection coefficients (VRC) as follows:

#### Equation 2-5: Power Absorbed By The Load

$$P_A = P_{ZO} \times \frac{1 - |\Gamma_L|^2}{|1 - \Gamma_S \Gamma_L|^2}$$

Where:

- $P_{ZO}$  is the power that the source will deliver to a matched load.
- $\Gamma_S$  and  $\Gamma_L$  are the VRCs of the source and load respectively.

This method for measuring the source match exploits this relationship by presenting the source with two different values of  $\Gamma_L$  and measuring the power delivered to the load under the two conditions. The load used is a thermistor mount that can be operated at two different resistances and can accurately measure the power absorbed. The thermistor mount type Keysight 478A with Option H75 or Option H76 normally operates at a DC resistance of 200  $\Omega$  giving an impedance at RF of 50  $\Omega$  and  $\Gamma_L$  close to zero. When the thermistor bridge is set to 100  $\Omega$  the RF impedance is 25  $\Omega$  giving a nominal  $\Gamma_L$  of 0.33. The effective efficiency of the thermistor mount remains constant under these two conditions so that the power ratio between operation at 200  $\Omega$  and 100  $\Omega$  can be accurately measured.

If the two reflection coefficients are  $\Gamma_1$  and  $\Gamma_2$  and these give the power measurements of  $P_1$  and  $P_2$  respectively (but the available power remains the same) then the two relationships can be equated as follows:

**Equation 2-6:**

$$P_1 \frac{|1 - \Gamma_s \Gamma_1|^2}{1 - |\Gamma_1|^2} = P_2 \frac{|1 - \Gamma_s \Gamma_2|^2}{1 - |\Gamma_2|^2}$$

Therefore:

**Equation 2-7:**

$$\frac{P_1 (1 - |\Gamma_2|^2)}{P_2 (1 - |\Gamma_1|^2)} = \frac{|1 - \Gamma_s \Gamma_2|^2}{|1 - \Gamma_s \Gamma_1|^2}$$

The left side of the equation can be replaced by the factor M as follows:

**Equation 2-8:**

$$\sqrt{M} = \frac{|1 - \Gamma_s \Gamma_2|^2}{|1 - \Gamma_s \Gamma_1|^2}$$

This cannot be directly solved for  $\Gamma_S$  because it is a complex quantity. In order to solve for  $\Gamma_S$  additional values of load reflection coefficient are required with a phase difference of approximately  $120^\circ$ . However an approximate solution using two values of  $\Gamma_L$  can give adequately accurate results provided the phase angle of the source is within  $\pm 40^\circ$  of  $0^\circ$  or  $\pm 180^\circ$ .

## Equipment

- Test power meter: Keysight 432A.
- Thermistor mount: Keysight 478A Option H75 or H76.
- Digital voltmeter (DVM): Keysight 3458A.

## Test Setup

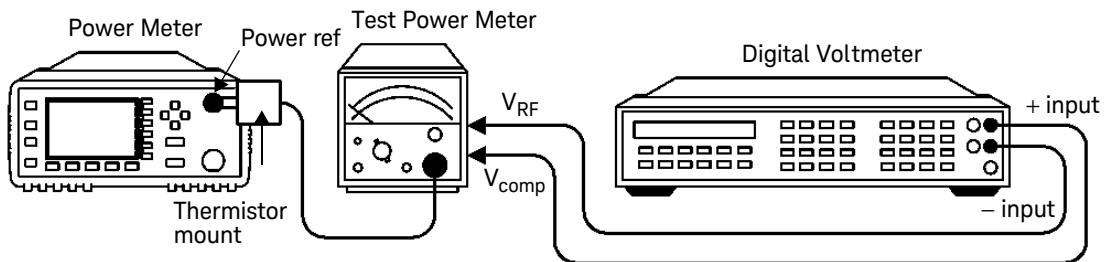

**Figure 2-10** Output Standing Wave Ratio Test Setup

## Procedure

Use the following procedure to perform the test:

**NOTE**

Steps 1 to 7 of this procedure require pre-requisite knowledge of some Keysight 432A and 478A parameters. Refer to [Appendix A](#) for further information.

- 1 Record the input VRC magnitude of the thermistor mount at 50 MHz with the Keysight 432A power meter set to 200  $\Omega$ :
  - $|R_1|$  \_\_\_\_\_
- 2 Record the input VRC magnitude of the thermistor mount at 50 MHz with the Keysight 432A power meter set to 100  $\Omega$ :
  - $|R_2|$  \_\_\_\_\_
- 3 Set the Keysight 432A mount resistance switch to 200  $\Omega$ .
- 4 Set the DVM to measure resistance:
 

Connect the DVM between the VRF connector on the rear panel of the Keysight 432A and pin 1 on the thermistor mount end of the sensor cable. Verify that no power is applied to the Keysight 432A.
- 5 Round off the DVM reading to two decimal places. Record this value as the first internal bridge resistance ( $R_1$ ) of the Keysight 432A:
  - $R_1$  \_\_\_\_\_  $\Omega$
- 6 Set the Keysight 432A mount resistance switch to 100  $\Omega$ .
- 7 Round off the DVM reading to two decimal places. Record this value as the second internal bridge resistance ( $R_2$ ) of the Keysight 432A:
  - $R_2$  \_\_\_\_\_  $\Omega$
- 8 Set the Keysight 432A mount resistance switch to 200  $\Omega$ .
- 9 Connect the equipment as shown in [Figure 2-10](#) ensuring that the DVM input leads are isolated from chassis ground.

**NOTE**

Ensure that the Keysight 432A and the power meter under test have been switched on for at least 30 minutes before performing the following steps.

**10** Preset the instrument:

- Press  then **Confirm** on the power meter.
- Set the Keysight 432A RANGE switch to Coarse Zero.
- Adjust the front panel Coarse Zero control to obtain a zero meter indication.

**11** Zero the Keysight 432A test power meter:

- Fine zero the Keysight 432A on the most sensitive range.
- Set the RANGE switch to 1 mW.

**12** Set the DVM to measure microvolts.

**13** Connect the positive and negative input leads to the Vcomp and VRF connectors respectively, on the rear panel of the Keysight 432A.

**14** Observe the reading on the DVM:

If less than 400  $\mu\text{V}$ , go to step 15. If 400  $\mu\text{V}$  or more, press and hold the Keysight 432A Fine Zero switch and adjust the Coarse Zero control so that the DVM indicates 200  $\mu\text{V}$  or less. Release the Fine Zero switch and go to step 15.

**15** Round off the DVM value to two decimal places. Record this value as  $V_0$ :

- $V_0$  \_\_\_\_\_

**16** Turn the power reference on:

Press , **Power Ref On**

**17** Round off the DVM reading to two decimal places. Record this value as  $V_1$ :

- $V_1$  \_\_\_\_\_

**18** Turn the power reference off:

Press , **Power Ref Off**

**19** Disconnect the DVM negative input lead from the VRF connector on the Keysight 432A. Reconnect it to the Keysight 432A chassis ground.

**20** Observe the reading on the DVM. Record this value as Vcomp

- $V_{\text{comp}}$  \_\_\_\_\_



- 21** Calculate the power measured from the power reference oscillator using equation 2-9:

**Equation 2-9:**

$$P_1 = \frac{2 \cdot V_{comp}(V_1 - V_0) + V_0^2 - V_1^2}{4 \cdot R_1}$$

- 22** Record the value  $P_1$ :

-  $P_1$  \_\_\_\_\_

- 23** Calculate the power measured with mount resistance set to 100  $\Omega$ :

- Set the Keysight 432A mount resistance switch to 100  $\Omega$ .
- Connect the equipment as shown in [Figure 2-10](#) ensuring that the DVM input leads are isolated from chassis ground.
- Repeat steps 15 to 20. Record the new values of  $V_0$ ,  $V_1$  and  $V_{comp}$ :

-  $V_0$  \_\_\_\_\_

-  $V_1$  \_\_\_\_\_

-  $V_{comp}$  \_\_\_\_\_

- 24** Calculate the power measured from the power reference oscillator using Equation 2-10 and record the value:

**Equation 2-10:**

$$P_2 = \frac{2 \cdot V_{comp}(V_1 - V_0) + V_0^2 - V_1^2}{4 \cdot R_2}$$

-  $P_2$  \_\_\_\_\_

**25** Calculate factor M using equation 2-11 and record the value:

**Equation 2-11:**

$$M = \frac{P_1(1 - |\Gamma_2|^2)}{P_2(1 - |\Gamma_1|^2)}$$

- P<sub>2</sub> \_\_\_\_\_

**26** Calculate the value of the output voltage reflection coefficient ( $|\Gamma_s|$ ) using equation 2-12 and record the value:

**Equation 2-12:**

$$|\Gamma_s| = \frac{(2|\Gamma_1|^M - 2|\Gamma_2|) \pm \sqrt{(2|\Gamma_2| - 2|\Gamma_1|^M)^2 - 4(|\Gamma_1|^2M - |\Gamma_2|^2)(M-1)}}{2(|\Gamma_1|^2M - |\Gamma_2|^2)}$$

One of the roots of this equation will be non-physical while the other gives a value for  $|\Gamma_s|$ .

-  $|\Gamma_s|$  \_\_\_\_\_

**27** Calculate the value of the output SWR using Equation 2-13 and record the value:

**Equation 2-13:**

$$SWR = \frac{(1 + |\Gamma_s|)}{(1 - |\Gamma_s|)}$$

- Output SWR \_\_\_\_\_

**28** Verify that the output SWR is not greater than the maximum value shown in the following table:

**NOTE**

The  $\Gamma_1$  and  $\Gamma_2$  values are measured for the thermistor mount (478A) using the network analyzer. For clarification, above  $\Gamma_1$  is measured at 200 ohm while  $\Gamma_2$  is measured at 100  $\Omega$ .

**Table 2-8** Output SWR Result

Max	Actual Result
1.06 <sup>[a]</sup>	_____
1.08 <sup>[b]</sup>	_____

[a] For instruments with the 50 MHz 1 mW output (power ref) connector mounted on the front panel.

[b] For instruments with the 50 MHz 1 mW output (power ref) connector mounted on the rear panel. This applies to models E4416A and E4417A with Option 003.

## Performance Test Record

Model Keysight E4416A/E4417A Power Meter

Tested by \_\_\_\_\_

Serial Number \_\_\_\_\_

Date \_\_\_\_\_

**Table 2-9** Performance Test Record

Test	Min Result	Channel A Actual Result	Channel B Actual Result	Max Result
Zero Test	-76.40 nW	_____	_____	+76.40 nW
<b>Instrument Accuracy</b>				
3.1623 $\mu$ W	3.0977 $\mu$ W	_____	_____	3.2269 $\mu$ W
10 $\mu$ W	9.904 $\mu$ W	_____	_____	10.096 $\mu$ W
31.6228 $\mu$ W	31.428 $\mu$ W	_____	_____	31.819 $\mu$ W
100 $\mu$ W	99.49 $\mu$ W	_____	_____	100.51 $\mu$ W
316.227 $\mu$ W	314.72 $\mu$ W	_____	_____	317.74 $\mu$ W
1 mW	0.9954 mW	_____	_____	1.0047 mW
3.1623 mW	3.1477 mW	_____	_____	3.1769 mW
10 mW	9.954 mW	_____	_____	10.046 mW
31.6228 mW	31.477 mW	_____	_____	31.769 mW
100 mW	99.54 mW	_____	_____	100.46 mW
<b>Power Reference</b>				
$P_{\text{meas}}$	0.991 mW	_____	_____	1.009 mW
Interface Test	Pass/Fail	_____	_____	Pass/Fail
<b>Functional Test</b>				
Low Range, 30 dBm pad	Pass/Fail	_____	_____	Pass/Fail
Upper Range, 30 dBm pad	Pass/Fail	_____	_____	Pass/Fail
Low Range, no pad	Pass/Fail	_____	_____	Pass/Fail

**Table 2-9** Performance Test Record (continued)

Test	Min Result	Channel A Actual Result	Channel B Actual Result	Max Result
Upper Range, no pad	Pass/Fail	_____	_____	Pass/Fail
Time Base Accuracy Test <sup>[a]</sup>	9.999 MHz	10.001 MHz	_____	N/A
Output Standing Wave Ratio Test <sup>[a]</sup>	N/A	1.06 <sup>[a],[b]</sup> 1.08 <sup>[a],[c]</sup>	_____	N/A

[a] This test is not channel related.

[b] For instruments with the 50 MHz 1 mW output (power ref) connector mounted on the front panel.

[c] For instruments with the 50 MHz 1 mW output (power ref) connector mounted on the rear panel. This applies to models E4416A and E4417A with Option 003 fitted.

THIS PAGE HAS BEEN INTENTIONALLY LEFT BLANK.

# 3 Adjustments

Introduction	72
Power Reference Oscillator Frequency Adjustment	74
Power Reference Oscillator Level Adjustment	77
Display Brightness and Contrast Adjustment	83

## Introduction

This chapter describes adjustments and checks which ensure proper performance of the power meter.

Adjustments are not usually required on any regular basis. They are normally performed only after a performance test has indicated that some parameters are out of specification. Performance tests must be completed after any repairs that may have altered the characteristics of the power meter. Performance tests are detailed in [Chapter 2](#). To determine which performance tests and adjustments to perform after a repair, see “[Post-Repair Adjustments](#)” on page 73.

## Safety Considerations

This warning must be followed for your protection and to avoid damage to the equipment being used.

### **WARNING**

**Adjustments described in this chapter are performed with power applied to the instrument and with protective covers removed. Maintenance should be performed only by trained personnel who are aware of the hazards involved. When the maintenance procedure can be performed without power, the power should be removed.**

---

## Equipment Required

The adjustment procedures include a list of recommended test equipment. The test equipment is also identified on the test setup diagrams.



## Post-Repair Adjustments

**Table 3-1** lists the adjustments related to repairs or replacement of any of the assemblies.

**Table 3-1** Post Repair Adjustments, Tests, and Checks

Assembly Replaced	Related Adjustments, Performance Tests or Self Tests
A1 Power Supply	Self Test
A2 Processor Assembly	Power Reference Frequency and Level Test/Adjustment. Display Brightness and Contrast Adjustment.
A3 Front Panel Assembly	Instrument Accuracy Test, Display Brightness and Contrast Adjustment.
A4 Comms Assembly	All automated Tests and Serial Interface Self Test.
A5 Daughter Assembly	Instrument Accuracy Test.
A6 Measurement Assembly	Instrument Accuracy Test.
W1 or W2 Power Sensor Cable	Instrument Accuracy Test.
BT1 Lithium Battery	Battery Self Test.
Power Reference Cable Kits	Power Reference Level Test.

## Power Reference Oscillator Frequency Adjustment

**NOTE**

Adjustment of the power reference oscillator frequency may also affect the output level of the oscillator. Therefore, after the frequency is adjusted to  $50.0 \pm 0.5$  MHz, check the output level should be checked as described in “**Power Reference Oscillator Level Adjustment**” on page 77. The power reference oscillator frequency is a nominal specification.

### Description

Variable inductor A2L9 is adjusted to set the power reference oscillator output frequency to  $50.0 \pm 0.5$  MHz. This frequency is a supplemental characteristic.

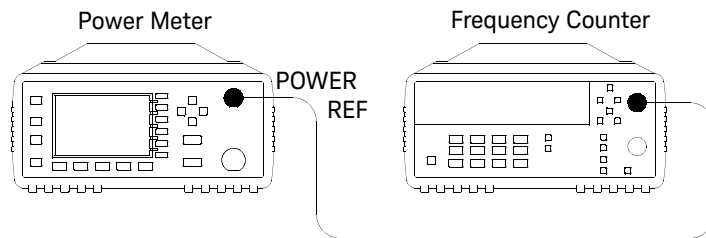



**Figure 3-1** Adjustment Setup

### Equipment

- Frequency Counter: Keysight 53132A.

## Procedure

- 1 Ensure that the power meter has been powered on for at least 30 minutes before making any measurements.
- 2 Connect the equipment as shown in [Figure 3-1](#). Set up the counter to measure frequency.
- 3 Turn the power reference on by pressing:
  -  , **Power Ref On** on the Keysight E4416A.
  -  , **Cal** ,  , **Power Ref On** on the Keysight E4417A.
- 4 Observe the reading on the frequency counter.  
If it is  $50.0 \pm 0.5$  MHz, no adjustment of the power reference oscillator frequency is necessary. If it is not within these limits, adjust the power reference oscillator frequency as described in step 5 and step 6.
- 5 Remove the power meter cover.
- 6 Adjust A2L9 to obtain a  $50.0 \pm 0.5$  MHz indication on the frequency counter. Refer to [Figure 3-2](#) for the position of A2L9.

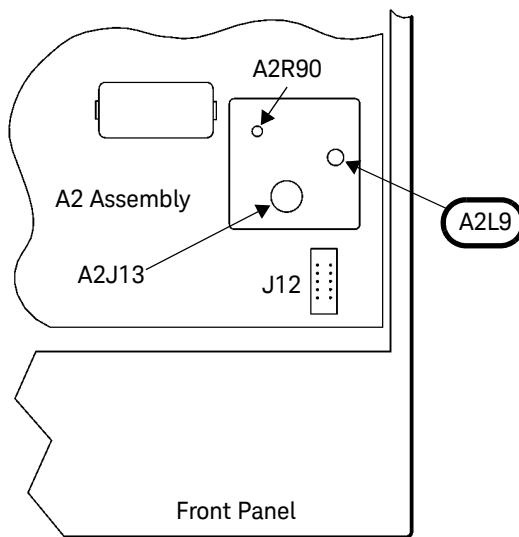

**Figure 3-2** A2L9 Adjustment Location

## Power Reference Oscillator Level Adjustment

### Description

This test adjusts the power level accuracy of the internal 50 MHz oscillator—also called the power reference oscillator.

The power reference oscillator output is factory adjusted to 1 mW  $\pm 0.4\%$ . This accuracy includes a performance limit of 0.1% and a system measurement uncertainty figure of 0.3% (traceable to the National Physical Laboratory (NPL), UK).

#### NOTE

The setting of the oscillator output accuracy is determined from the system measurement uncertainty plus any chosen test line limit. For example, if a test line limit of 1 mW  $\pm 0.2\%$  was chosen while maintaining a system measurement uncertainty of  $\pm 0.3\%$ , the overall accuracy of the test setup for the 1 mW power output becomes 0.3% + 0.2%, giving a setting accuracy of 0.5%.

If an equivalent measurement system is employed for post-factory test, the power reference oscillator output can again be set to 1 mW  $\pm 0.4\%$ . This setting is sufficient to ensure that the power reference oscillator meets the accuracy specification of  $\pm 0.5\%$  after 2 years. This specification includes the  $\pm 0.4\%$  setting and also takes into account other factors that will contribute to determining the accuracy after 2 years. The complete breakdown of the  $\pm 0.5\%$  specification is as follows:

- Test line limit: 0.1%.
- System uncertainty: 0.3%.
- 2 year oscillator drift: 0.04%.
- Delta environment:  $< 0.06\%$ .

The following adjustment procedure ensure the power reference oscillator meets the post-factory accuracy setting of  $\pm 0.4\%$ .

**NOTE**

To ensure maximum accuracy in re-adjusting the power reference oscillator output, this procedure provides step-by-step instructions for using Keysight test instruments of known capability. Signal acquisition criteria may vary if alternative test instruments are used. In such cases refer to the manufacturer's guidelines for further information.

**NOTE**

The power meter may be returned to the nearest Keysight Technologies office to have the power reference oscillator checked and/or adjusted.

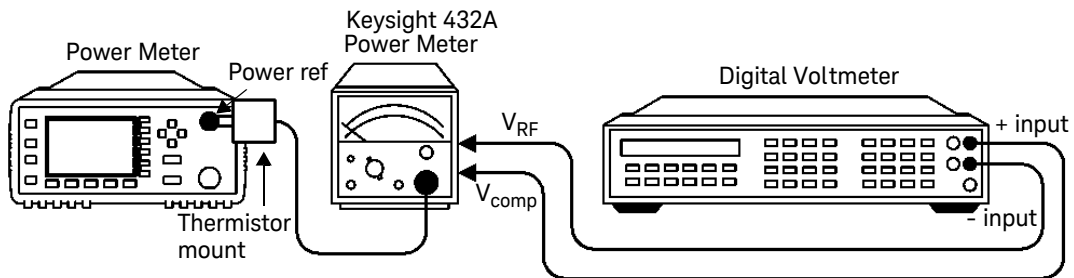

**Figure 3-3** Adjustment Setup

For this adjustment the following mathematical assumptions are made:

**Equation 1:**

$$P_{meas} = \frac{2V_{comp}(V_1 - V_0) + V_0^2 - V_1^2}{4R(\text{CalibrationFactor})}$$

can be manipulated to give the following:

**Equation 2:**

$$V_1 = V_{comp} + V_0 - \sqrt{V_{comp}^2 - (10)^{-3}(4R)(\text{CalibrationFactor})}$$

by using the following assumptions:

$$V_0^2 - V_1^2 = -(V_1 - V_0)^2$$

The error in doing this is:

$$-(V_1^2 + V_0^2 - 2V_1V_0) - (V_0^2 - V_1^2) = -2V_0^2 + 2V_1V_0 = 2V_0(V_1 - V_0)$$

So if  $2V_0(V_1 - V_0) \ll 2V_{comp}(V_1 - V_0)$ , that is,  $V_0 \ll V_{comp}$  then the error can be ignored. In practice  $V_{comp} \sim 4\text{Volts}$  and  $V_0 < 400\mu\text{V}$ . The error is less than 0.01%.

By substituting equation 3 into equation 1 and manipulating the result you get:

$$0 = (V_1 - V_0)^2 - 2V_{comp}(V_1 - V_0) + 4(10^{-3})R(\text{CalibrationFactor})$$

This quadratic can be solved to give equation 2.

The definitions of the terms in equation 2 are:

- $V_0$  is the voltage measured between  $V_{comp}$  and  $V_{RF}$  with no power applied and after the Keysight 432A has been zeroed.
- $V_1$  is the voltage measured between  $V_{comp}$  and  $V_{RF}$  with power applied. This power is approximately 1 mW.
- $V_{comp}$  is the voltage between the Keysight 432A  $V_{comp}$  connector and chassis ground with power applied.
- $R$  is the resistance of the mount resistor in the Keysight 432A power meter
- Calibration Factor is the value of the thermistor mount at 50 MHz.

## Equipment

- Test power meter: Keysight 432A.
- Thermistor Mount: Keysight 478A Option H75 or H76.
- Digital Voltmeter (DVM): Keysight 3458A.

## Procedure

### NOTE

The procedure details the key presses required on the Keysight E4416A. For the Keysight E4417A the equivalent key presses should be performed on both channels.

- 1 Set up the DVM to measure resistance. Connect the DVM between the VRF connector on the rear panel of the Keysight 432A and pin 1 on the thermistor mount end of the sensor cable. Verify that no power is applied to the Keysight 478A.
- 2 Round off the DVM reading to two decimal places and record this value as the internal bridge resistance (R) of the test power meter (approximately 200  $\Omega$ ).  
– R (Internal Bridge Resistance) \_\_\_\_\_  $\Omega$
- 3 Connect the equipment as shown in [Figure 3-3](#). The leads should be isolated from ground. Ensure that the power reference oscillator is off. Ensure that both the power meter under test and the Keysight 432A have been powered on for at least 30 minutes before proceeding to the next step.
- 4 Set the Keysight 432A range switch to coarse zero and adjust the front panel coarse zero control to obtain a zero meter indication.
- 5 Fine zero the Keysight 432A on the most sensitive range, then set the range switch to 1 mW.

### NOTE

Ensure that the DVM input leads are isolated from chassis ground when performing the next step.

- 6 Set up the DVM to measure microvolts.
- 7 Connect the positive and negative input leads, respectively, to the  $V_{\text{comp}}$  and  $V_{\text{RF}}$  connectors on the rear panel of the Keysight 432A.
- 8 Observe the reading on the DVM. If less than 400  $\mu\text{V}$ , proceed with the next step. If 400  $\mu\text{V}$  or greater, press and hold the Keysight 432A fine zero switch and adjust the coarse zero control so that the DVM indicates 200  $\mu\text{V}$  or less. Then release the fine zero switch and proceed to the next step.



- 9** Round off the DVM reading to the nearest microvolt and record this value as  $V_0$ .
- $V_0$  \_\_\_\_\_ V
  - Disconnect the DVM negative input lead from the  $V_{RF}$  connector on the test power meter and reconnect it to chassis ground.

**10** Turn the power reference on:

- Press  , **Power Ref On**

**11** Record the reading on the DVM to two decimal places. This is  $V_{comp}$ .

- $V_{comp}$  \_\_\_\_\_ V

**12** Reconnect the negative lead to the VRF connector on the rear panel of the Keysight 432A. The DVM is now set up to measure  $V_1$  which represents the power reference oscillator output level.

**13** Calculate the required value of  $V_1$  using equation 2.

$$V_1 = V_{comp} + V_0 - \sqrt{V_{comp}^2 - (10)^{-3} (4R)(CalibrationFactor)}$$

**14** Remove the power meter's cover and adjust A2R90 until the DVM indicates the calculated value of  $V_1$ . Refer to [Figure 3-4](#) for the position of A2R90:

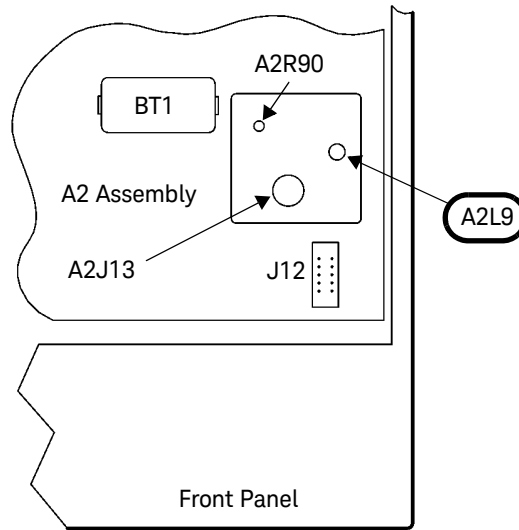

**Figure 3-4** A2R90 Adjustment Location

### Measurement Uncertainty

Refer to Appendix C, [Measurement Uncertainty Analysis - Power Reference Level Test](#).

# Display Brightness and Contrast Adjustment

## Introduction

The following procedure should be performed whenever a front panel assembly or processor assembly is replaced.



The brightness is controlled automatically after executing the **Set Brightness** softkey. Press **System**, **More**, **Service** and **Display** to locate this softkey menu.

### NOTE

The contrast adjustment is subjective and varies according to individual user requirements.

---

## Procedure

- 1 Access the **Display** softkey menu and use the  softkey to increase the contrast, or the  softkey to decrease the contrast of the display.
- 2 When the desired display contrast level is obtained, press the **Set Contrast** softkey, located under the **Service** softkey menu.

THIS PAGE HAS BEEN INTENTIONALLY LEFT BLANK.

# 4 Theory of Operation

Introduction	86
A1 Power Supply	87
A2 Processor Assembly	88
A3 Front Panel Assembly	91
A4 Comms Assembly	92
A5 Daughter Assembly	93
A6 Measurement Assembly	94
Functional Block Diagram	98

## Introduction

This chapter describes how each of the power meter's assemblies operate.

A functional block diagram is included at the end of the chapter giving an overall view of the power meter's operation.

## A1 Power Supply

The A1 power supply/battery charger is a 20 W, 47 to 440 Hz switching power supply producing three DC voltages, (+5 V, +12 V, -12 V). It is used to power the subassemblies when operating from an ac power source. The power supply can be driven by AC power voltages in the range 85 to 264 V.

Power is distributed to the meter subassemblies via the processor assembly (For further information refer to “[A2 Processor Assembly](#)” on page 88).

The ac line fuse is located in the line input module on the power meter's rear panel (Keysight Part Number 2110-0957). The fuse holder contains a spare fuse as standard on shipment.

## A2 Processor Assembly

The processor assembly contains the following:

- Microcontroller and associated circuits.
- Power-on/ standby control and switching.
- 1 mW reference calibrator.
- Recorder outputs TTL input/output.
- Front panel drivers.

It provides that platform on which the power meter can run, facilitating the system inputs and outputs.

Regulated DC voltages at +12 V, –12 V and +5 V are converted by the A1 power supply assembly when AC power is connected to the rear panel or the optional rechargeable battery is fitted. The DC voltages are connected and distributed to the rest of the system by circuits on the processor assembly. When the key on the front panel is pressed a bistable latch changes state. This in turn applies the correct gate voltages to turn on three MOSFET switches, which connects the power supply unit voltages to the distributed power buses. The bistable latch is connected to a permanent power-supply which has the backup of battery power when AC mains is removed from the power meter. The +12 V supply is used to power the fan. This is filtered to decouple it from the rest of the system. When the optional rechargeable battery is fitted and the meter is in standby and connected to the AC power supply, the rechargeable battery recharges and the fan is powered on.

The reference oscillator has a 50 MHz oscillator circuit with automatic level control (ALC). The oscillator output is level detected and that level is compared to a temperature stable precision reference voltage. This comparison produces an error signal that gives negative feedback control of the oscillator output power. The frequency and power level of the calibrator are factory set to provide a 50 MHz 1 mW transfer standard. The precision reference voltage and the ALC control signal are both measured in the calibrator self test. The calibrator is switched on or off using a signal from the microcontroller. The front panel LED indicator is switched with a separate microcontroller signal. The recorder outputs are driven from a dual 12 bit DAC which is driven by the microcontroller. The dual DAC outputs are buffered, filtered and scaled to give a 1 V full scale output nominal.



The recorder is a 12 bit DAC driven by the microcontroller. The DAC output is buffered, filtered and scaled to give a 1 V full scale output with a nominal 1 k $\Omega$  output impedance.

Circuitry for the keyboard driver includes some damage protection, but it is basically a direct connection from the keypad row and column matrix to the microcontroller's control lines.

The LCD controller on the A3 front panel assembly is configured as a memory mapped peripheral, and as such requires only to be fed with the appropriate address, data and control lines from the microcontroller circuits. The bias voltage for the LCD is produced by a DC to DC converter that takes the +5 V (DIST) voltage and converts that to a nominal +21 V. The DC to DC converter is adjusted by a combination of the contrast

control signal from the microcontroller and the temperature sense voltage that is generated on the A3 front panel assembly. The temperature sense voltage helps to compensate for the normal variation of LCD contrast with temperature. Current to the LCD's LED backlight array is sourced from a constant current circuit that compensates for variation in LED knee voltage. A control input to this circuit from the front panel temperature sense voltage allows for de-rating of the maximum LED current at high operating temperatures. A control input from the microcontroller allows the optimum backlight brightness to be factory set. The temperature sense voltage, LED current and LCD bias voltage are all measured at self test.

An analog multiplexer provides means by which several diagnostic points can be switched to the A6 measurement assembly for analogue to digital conversion. The microcontroller uses this function to perform a self test.

A6 measurement assembly to microcontroller communication is conducted on a parallel expansion bus. This bus is connected to the bi-directional serial port on the microcontroller via buffers. The 20 MHz system clock

and some control signals are connected to the measurement modules. The measurement module interface is completed with the distribution of switched and direct power (+12 V, -12 V and +5 V).

The TTL outputs are connected to the A6 processor assembly via in line resistors located on the A4 interface assembly. A TTL logic level is output from the processor assembly when the user defined windows based limits are exceeded.

The TTL inputs are connected to the processor card via in line resistors located on the interface card and can be used to initiate zero and calibration cycles on the power meter.

The microcontroller circuits that control all the above functions, and provide platform for the system software to run on, comprise the microcontroller itself, memory, and clock and logic circuits. The logic circuits have the function of ensuring the correct sequencing and decoding of the control signals for the various peripherals. The crystal oscillator clock circuit is buffered and distributed to the A4 interface assembly and the A5 daughter assembly. The program memory for the microcontroller is FLASH EEPROM to allow for in-circuit programming. The static RAM is split into volatile and non-volatile blocks, with the power for the non-volatile RAM being connected to the permanent (battery backed) power supply.

**NOTE**

It is advisable to replace the RAM battery A2BT1 every three years. If the battery fails or drops below 3 V the RAM will lose the following information when power is disconnected from the meter:

- Unit Serial Number.
  - Revision letter of Processor Card.
  - Unit Option.
  - User defined setups.
  - User defined sensor calibration tables.
-

## A3 Front Panel Assembly

The front panel assembly is made up of a liquid crystal display (LCD), a keypad and, depending on the power meter option, a power reference cable assembly and a sensor cable assembly.

There are two inputs to the front panel assembly:

- The flex circuit from connector A2J4 of the processor assembly which controls the keypad.
- The ribbon cable from A2J3 of the processor assembly which controls the LCD display.

The power meter self tests contain display tests. These are

accessed by pressing **System**, **More**, **Service**, **Self Test**, **Bitmap Displays**.

## A4 Comms Assembly

The comms assembly contains the circuitry required for remote control of the power meter. This assembly supports parallel and serial interfaces.

The GPIB interface is supported by a protocol controller integrated circuit and two physical interface buffers. The system clock is divided by four to provide the GPIB controller integrated circuit clock signal.

The RS232 and RS422 interface is supported by a single Universal Asynchronous Receiver/Transceiver (UART) integrated circuit and a programmable transceiver. The programmable transceiver can be configured for either RS232 or RS422. The remote interface is designated a DTE (Data Terminal Equipment).

The programmable baud rate generator in the UART is driven from the system clock (20 MHz) which allows baud rates in the range 50 to 20 MHz.

The whole assembly is connected to data, address, and control signals from the A2 processor assembly.

The comms assembly also provides a filtered path for the single/dual recorder output signal and the TTL input and output signals. It also provides ESD protection for the RS232.422, TTL I/O, and recorder outputs.

## A5 Daughter Assembly

The A5 daughter assembly is loaded vertically into the A2 processor assembly.

There are 3 main connectors on the daughter card which provide the interconnect between the A2 processor assembly and the A6 measurement assembly.

Additionally there are two SMB connectors for the external trigger signals that are routed using cable assemblies to the rear panel.

In addition the A5 daughter card provides support functions for the measurement assemblies. These functions take power and signals from the A2 processor assembly and generate the power and signals required by the A6 measurement assembly. The A5 daughter assembly also provides common trigger functions that are routed to both the A6 measurement assemblies.

The functions provided are:

- Clock buffering and distribution.
- External trigger output buffer.
- External trigger input comparator and buffer.
- +2.5 V precision reference.
- +11 V regulator.
- +3.3 V regulator.
- +2.5 V regulator.
- $\pm 5$  V regulators.

## A6 Measurement Assembly

There is one measurement assembly in the E4416A and two in the E4417A. As the E4416 and E4417 are peak and average power meters that are compatible with all Keysight power sensors in the 848x Series, N8480 Series and E Series, the measurement assembly has two measurement paths. One path deals with average only measurements and this is the path that is compatible with the 848x Series, N8480 Series and E-Series sensors. The other path provides the peak measurements. In addition to these two measurement paths there is a DSP subsystem which provides the signal processing of the digitized analogue signals together with various ancillary support functions.

### Average Path Operation

The measurement assembly amplifies and converts the chopped AC signal produced by the power sensor (either 848x Series power sensors, N8480 Series power sensors or E-Series power sensors) into a 32 bit digital word. This digital word is proportional to the input RF power level applied to the power sensor.

With reference to the block diagram at the end of this chapter, the input amplifier amplifies the chopped AC input signal. This operational amplifier in combination with a single bipolar transistor in the power sensor, produce a feedback amplifier which has a gain of approximately 500. The feedback line shown sets the gain and also biases the transistor. The differential amplifier removes any common mode noise or interference. It uses a special ground wire ("sensor ground")-connected close to the RF bulkhead in the power sensor-as its second input.

The band pass filter represents the filtering action of the input amplifier. When the power meter is working with an E-Series power sensor the equalizer is switched on to reduce the high pass cut off frequency of the input amplifier. This improves the settling time in fast mode operation.

The output of the equalizer is split into two paths. One path is amplified by a gain of 100. Both signals are each converted to digital words by a dual analog to digital converter (ADC). The ADC's sampling rate has an integer relationship with the chop frequency, thus giving a fixed number of samples per chop cycle.

In the event of a power overload—which could cause the input amplifier to saturate—a window comparator function trips which generates an interrupt to the processor assembly through the FPGA. The FPGA also forces the sensor into upper range using the I2C\_NEN line.

The ADC uses an I2S interface into the DSP where the samples are de-chopped and converted into digital words proportional to input level. The chosen channel is then filtered and stored in a buffer ready for reading by the host processor.

An analogue switch is used to inject a calibration into this path to allow calibration of the gain ratio between the two ranges.

## Normal Path

The second path, or normal path, deals with peak mode measurements. Here the input signal is the detected power envelope of the RF input to the sensor. The E9320-Series sensor detects this and, for peak mode measurements, amplifies it as a fully differential voltage signal with a bandwidth from DC to 5 MHz. The normal path processes the output of an E9320-Series sensor and converts it to a form suitable for digitizing in a 12 bit ADC, at a rate of 20 M samples/sec. The sensor has a 50  $\Omega$  source impedance for each of the differential lines, the sensor cable has a differential impedance of 100  $\Omega$  and the measurement card has a 100  $\Omega$  load impedance at the input to the first amplifier. The purposes of the first amplifier are to buffer the input signal, to allow offset control and to drive the anti-alias filter. Offset control comes from the main processor via a DAC into the first amplifier and a feedback control algorithm carried out during zeroing ensures that gross voltage offsets are nulled out before reaching the ADC.

The offset-corrected amplifier output is then filtered. The filter is a differential implementation of a 9th order Bessel low-pass filter, designed for a flat delay of approximately 100ns, a 3 dB bandwidth of approximately 5 MHz and 22 dB attenuation at 15 MHz.

The filter output is fed to a buffer amplifier which has a gain of 1.1. This ensures that switching transients are not passed backwards into the filter and provides a

low impedance output for the HI\_GAIN switch. The combined gain of the buffer amplifier and filter is approximately unity. An attenuator and switch circuit follows this. The attenuation can be set to 1 or 16. The attenuation is controlled by the level of the signal prior to the filter, which is sensed with a comparator and fed into a latch and the FPGA. Logic within the FPGA controls the switches that select the applied attenuation and hence the gain of the normal path. As the level sense occurs before the 100 ns delay of the filter, the FPGA and attenuators have 100 ns to select the right gain for presentation to the ADC. A differential amplifier with a gain of 3 follows the attenuator.

The ADC has a bipolar range but the power signal is essentially unipolar.

To utilize the full ADC range an offset is summed in to the signal just prior to the ADC in an offset summer circuit. The outputs of the summer are arranged to give a full-scale negative input to the ADC, so it reads circa (but greater than) -2048 when zero volts is applied to the normal path input. (The ADC range is -2048 to 2047.) There is a further filter that removes high frequency noise, originating in the amplifier chain, from the ADC input. It has a 20 MHz theoretical cut-off (-3 dB) frequency.

The ADC is a 12-bit converter running at 20 MHz. Samples from the ADC are combined with the normal path gain setting and the sensor range to derive the power measurement. The ADC output and the range control bits are fed to the FPGA. The FPGA controls a triggered acquisition into SDRAM. The acquisition parameters (such as pre-trigger, post trigger and trigger level) are controlled by the main processor.

The DSP transfers the acquired samples into its local memory where it then performs the required processing to enable the demanded measurements. This includes range correction, digital filters, linearity correction, averaging together with display trace processing. The DSP generates an interrupt to the processor when results are ready.

The processor assembly communicates with the DSP through the FPGA. The DSP is loaded with the appropriate program by the processor assembly depending on sensor type and required measurement mode. The processor assembly loads the FPGA using a serial configuration bus.



## Ancillary Functions

The measurement assembly also measures the sensor resistor voltage to detect whether a power sensor is present. If a power sensor is connected (or disconnected) an interrupt to the A2 processor assembly is generated.

Circuitry on the board is then used by the processor to determine the sensor model, and whether it's connected to the front or rear panel. The processor then configures the board's ancillary functions, such as chop frequency, chop voltage levels and also programmes the DSP with the appropriate code for that sensor type. If the sensor was one of the E-Series then the processor reads calibration data from the sensor's E2PROM using the I2C bus. The processor then uses the board's auxiliary ADC (XADC) to measure the sensor temperature which is used in conjunction with the calibration data to provide temperature corrected power measurements.

This assembly produces the differential drive signal for the power sensor's chopper. The processor assembly programs the level and frequency of these signals:

- For 848x Series power sensors, this signal is 0 V and –10 V at 217 Hz.
- For E-Series power sensors, this signal is +7 V and –3 V at 434 Hz.

The XADC is also used to support system built in test by being capable of digitizing a signal routed to it from the processor assembly.

As described earlier the E-Series power sensors have built in serial EEPROM and range switching which is controlled or accessed via the measurement assembly. The N-chop sensor wire used by the 848x Series power sensors doubles as a serial clock and the sensor resistor line doubles as a bi-directional serial data line. The wire labelled "Auto Zero" is also used as a serial bus enable control.

The auto zero line is grounded to the sensor ground line when an 848x Series power sensor is used. Autozeroing is accomplished without the need for this signal in the power meter.

All clocks are derived from the 20 MHz system clock that is generated on the A2 processor assembly and distributed on the A5 daughter assembly.

The E9320 sensors are provided with switchable power supplies.

## Functional Block Diagram

The following two pages contain a functional block diagram for the instrument giving an overall view of the power meter's operation.

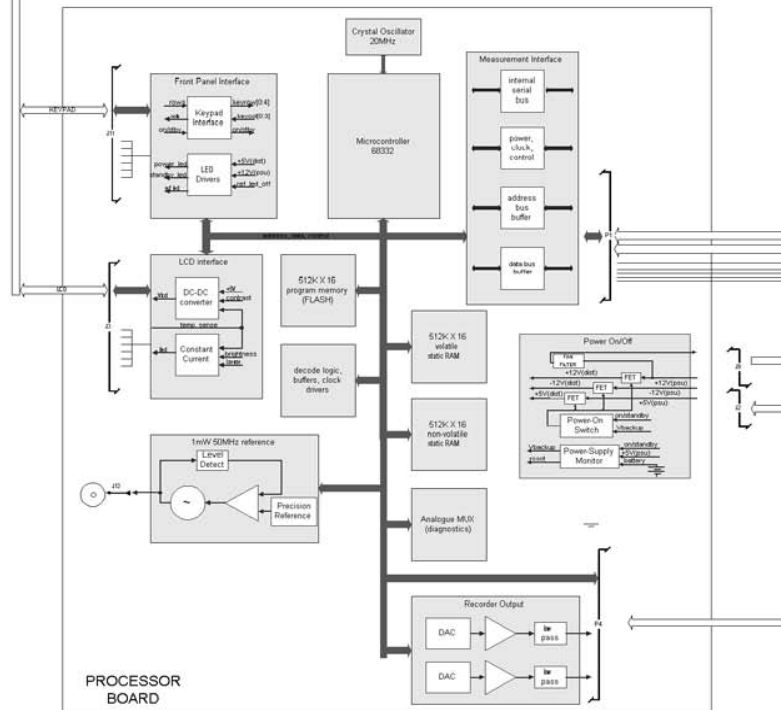
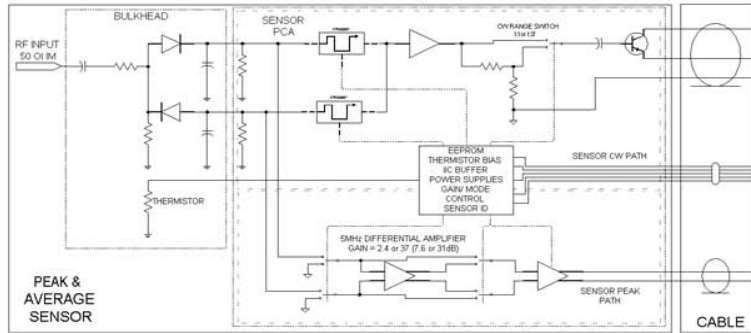

# 4 Theory of Operation

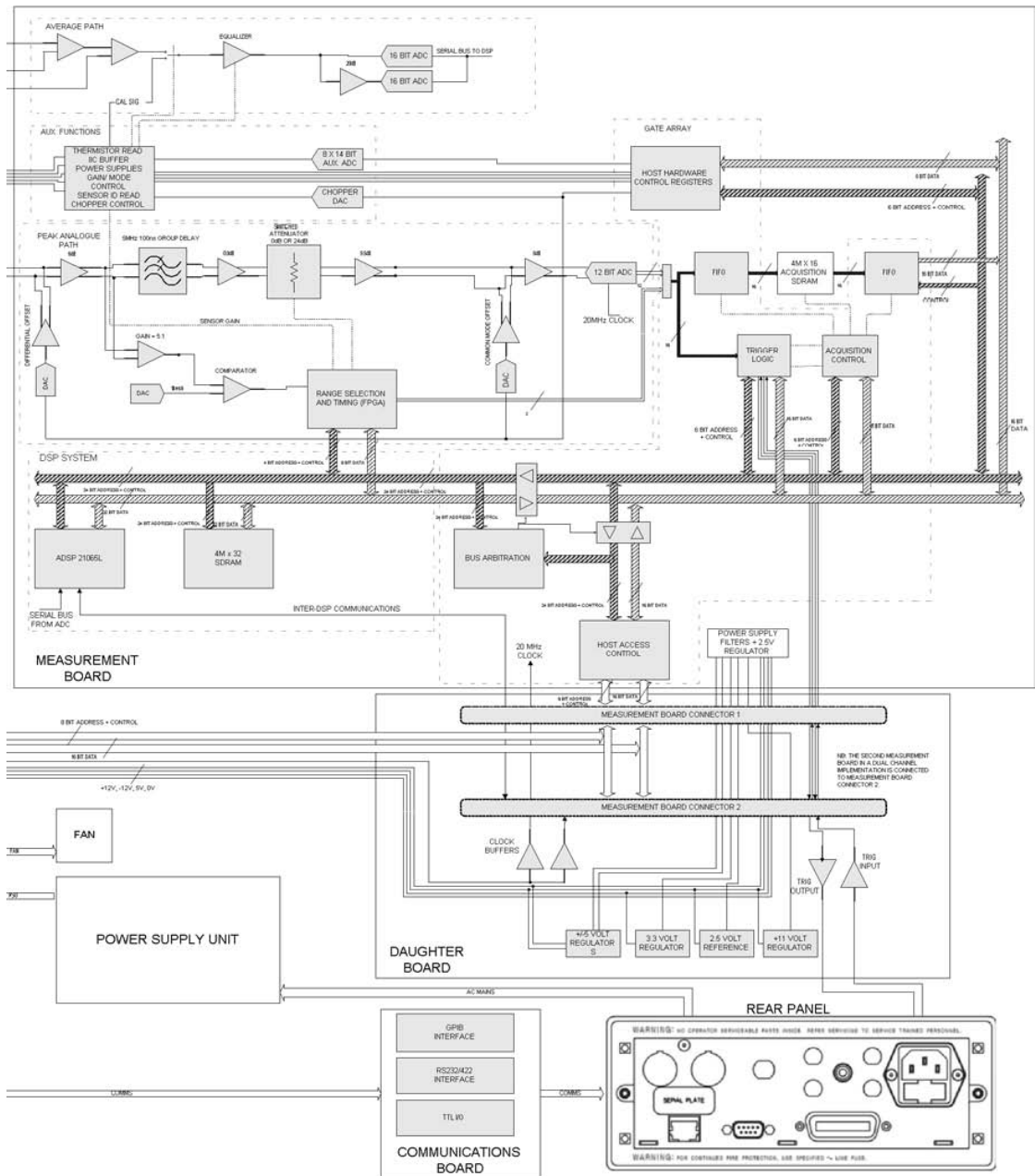

# 5 Replaceable Parts

Introduction	102
Assembly Part Numbers	103
Front Panel Connector Repair	105
Firmware Upgrades	106
Assembly and Disassembly Guidelines	107

## Introduction

This chapter contains details of some of the higher level components and assemblies which can be ordered from Keysight Technologies. It also details how to assemble and disassemble the power meter for repair.

To order parts contact your local Keysight Technologies Sales and Service Office.

To return your power meter for servicing at a qualified service center refer to "Contacting Keysight Technologies" in chapter 7 of the EPM-P Series Peak and Average Power Meter User's Guide.

## Assembly Part Numbers

Reference Designator	Description	Keysight Part Number
A1	Power Supply Assembly	0950-2649
	Power Supply and Charger Assembly (Option K01 only)	0950-3681
	Deck Assembly	E4416-61005
A2	Processor Assembly	E4416-60006
A301	Front Panel Assembly for: Keysight E4416A and Keysight E4416A Option 002	
	New	E4416-60201
A302	Front Panel Assembly for: Keysight E4416A Option 003	
	New	E4416-60202
A303	Front Panel Assembly for: Keysight E4417A and Keysight E4417A Option 002	
	New	E4417-60201
	Adapter RF N-SMA	E4418-20009
A304	Front Panel Assembly for: Keysight E4417A Option 003	
	New	E4417-60202
	Adapter RF N-SMA	E4418-20009
A4	Comms Assembly	E4418-60012
A5	Daughter Assembly for: Keysight E4416A and Keysight E4417A	E4416-60007
A6	Measurement Assembly	
	New	E4416-60004
A7	Fan Assembly	E4418-61004

## 5 Replaceable Parts

Reference Designator	Description	Keysight Part Number
BT1	Lithium (RAM) Battery	1420-0338
MP1	Bail Handle	34401-45011
MP2	Front Bumper	34401-86011
MP3	Rear Bumper	34401-86012
MP4	Outer Cover for: Keysight E4416/7A	E4418-61027
MP5	Rear Bezel	E4418-20008
MP6	Instrument Chassis Assembly (Includes push-fit line module)	E4416-61004
MP6J1	Push-Fit Line Module	E4418-61002
W3	Recorder Output Cable Assy	E4418-61015
	Front Sensor Cable Assembly Kit	E4416-61013
	Rear Sensor Cable Assembly Kit	E4416-61014
	Front Power Reference Cable Kit	E4418-61811
	Rear Power Reference Cable Kit	E4418-61813
	Flex Circuit	E4418-66502
	Rubber Keypad	E4416-40001



## Front Panel Connector Repair

The front panel assembly is an exchange assembly. However, if front panel sensor cables or power reference cables are faulty they should be replaced by ordering the appropriate kit and following the assembly/disassembly procedure. The instrument accuracy tests should then be carried out to verify the functionality of the new part. Refer to [Chapter 2](#) for further information on instrument accuracy tests.

## Firmware Upgrades

The power meter's firmware is upgraded by downloading new firmware files from disc via computer GPIB or RS232/422 interface. This requires the upgraded firmware files and the Keysight EPM and EPM-P Dload program for Windows 95 and NT. Both are supplied with firmware upgrade kit E4416-61016 or from the internet at <http://www.keysight.com/find/powermeters>

To determine the firmware version currently installed in your power meter, press:

– **System**, **More**, **Service**, **Version**.

Firmware must be downloaded after the processor board is replaced.

## Assembly and Disassembly Guidelines

The guidelines in this section describe the removal and replacement of the major assemblies in the Keysight E4416A and Keysight E4417A power meters.

Once an assembly has been replaced, refer to “**Post-Repair Adjustments**” on page 73 to ensure that the correct performance tests and adjustments are carried out.

### WARNING

**Refer to the safety symbols on the power meter and "Equipment Operation" at the beginning of the document before operating this power meter with the cover removed. Failure to comply with the safety precautions can result in severe or fatal injury.**

---

### WARNING

**Before carrying out any assembly or disassembly of the power meter ensure that you disconnect the power cord. Even with the power meter switched off there are potentially dangerous voltages present on the power supply assembly.**

---

## Removing the Power Meter Cover

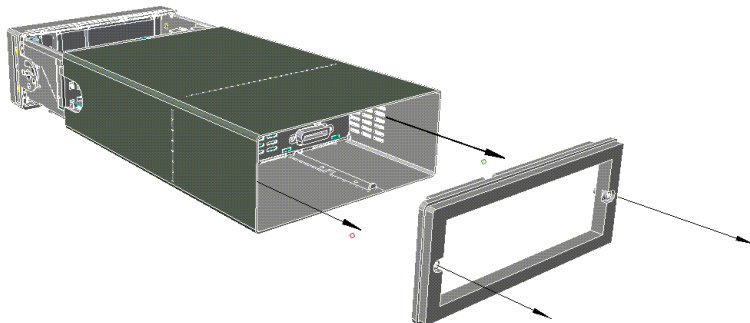

When replacing the power meter cover retighten the captive screws in the rear bezel using a 9 lb/in T15 screw driver.

## Removing the A1 Power Supply Assembly

- 1 Remove the power supply cover by lifting it out.
- 2 Disconnect the line input module from the chassis and power supply assembly.
- 3 Disconnect the cable assembly from the power supply which connects to the A2 processor assembly.
- 4 Unscrew the power supply assembly and lift out the power supply (When replacing these screws use a 9 lb/in T15 screw driver).

### WARNING

When replacing the power supply unit in the power meter ensure that all earth wiring is reconnected. There are two terminals to check:

The first is the force fit connector to the power supply unit itself. It is essential that the gap between the terminal and the adjacent large capacitor is maximized. Fit the connector so that its flat side faces towards the large capacitor. The second, a closed loop terminal bonded to the chassis with an M3.5 machine screw (use a 9 lb/in T15 screw driver). All the protective earth wiring can be identified by the insulation color green with a yellow stripe.

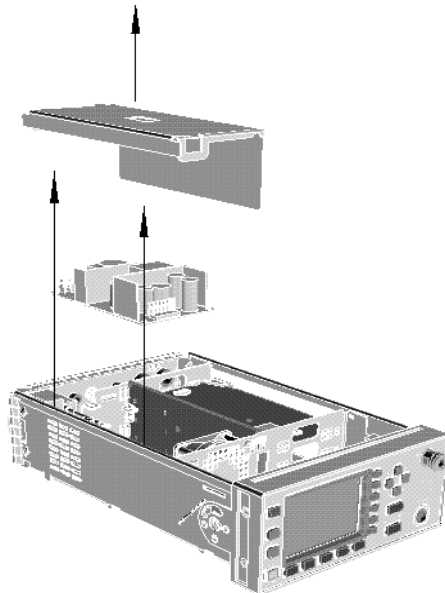

## Removing the A2 Processor Assembly

- 1 Remove the A5 daughter and A6 measurement assemblies as described on [page 113](#).
- 2 Move the A2 plastic support bracket to its forward position using the two side levers, unclip the flexi-cable retaining bar on the front panel keypad and front panel LCD cable connectors and disconnect the cable.
- 3 Disconnect the following cables from the A2 processor assembly:
  - Power reference semi-rigid.
  - Fan connector.
  - Power supply connector.
- 4 Turn the power meter upside down and remove the three screws as shown. When replacing these screws use a 6 lb/in T10 screw driver.
- 5 Push the A2 processor assembly towards the front panel to release it from the 50-pin connector. Lift it upwards to remove.

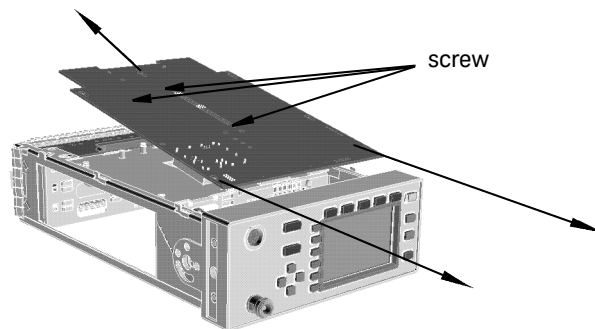

### NOTE

When re-assembling the processor board, ensure the A2 plastic support bracket is returned to its locked position.

### NOTE

After replacing a processor board, the Power Reference Frequency and Level must be checked. For further information refer to [Chapter 2, "Performance Test Record"](#).

**NOTE**

After replacing a processor board, the display brightness and contrast must be adjusted. For further information refer to [Chapter 3, "Display Brightness and Contrast Adjustment"](#).

---

**NOTE**

Firmware should be downloaded to the instrument after the processor board is replaced. Refer to ["Firmware Upgrades"](#) on page 106.

---

## Removing the A4 Comms Assembly

- 1 Remove the A2 processor, A5 daughter and A6 measurement assemblies as shown on [page 109](#) and [page 113](#).
- 2 Disconnect the line power module from the A1 power supply and the chassis.
- 3 Disconnect the earth wire screw. When replacing this screw use a 9 lb/in T15 screw driver.
- 4 Remove the two screws on the underside of the deck assembly. Remove the assembly by sliding forward and tilting up from the rear. When replacing these screws use a 21 lb/in T15 screw driver.

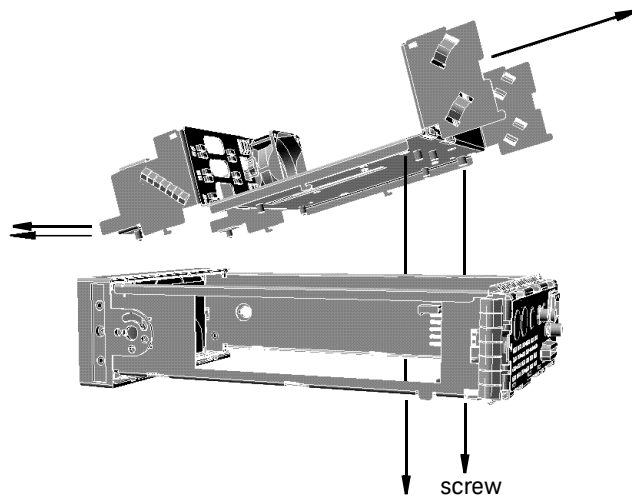

- 5 Unscrew the GPIB and RS232/422 connectors from the rear panel. When replacing these screws use a 6 lb/in 9/32 in socket.

## 5 Replaceable Parts

- 6** Disconnect the Recorder cable for channel A from J23 pins 1,2,3. Disconnect the Recorder cable for channel B from J23 pins 4,5,6.
- 7** Lift the A4 Comms assembly from the two standoffs and slide it out.

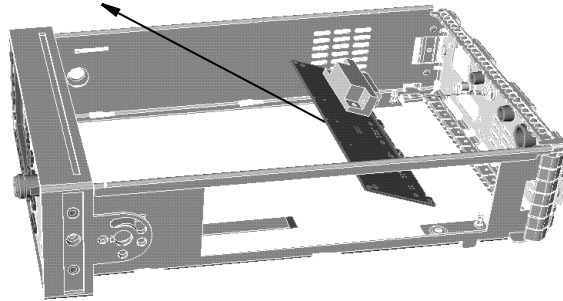



## Removing the A5 Daughter or A6 Measurement Assemblies

- 1 Disconnect the flex circuit from measurement assembly.

**NOTE**

Take care when disconnecting the flex circuit from the measurement assembly.

- 2 Loosen release tabs on measurement assembly and then remove vibration support bracket.
- 3 Slide out the measurement assembly from the side of the power meter.
- 4 The daughter assembly is removed vertically.

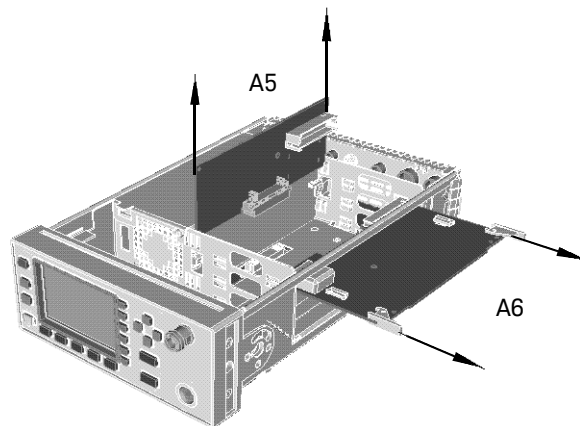

## Removing the A7 Fan Assembly

- 1** Remove the A1 power supply assembly as shown on [page 108](#).
- 2** Remove the pins which attach the fan to the chassis.
- 3** Remove the fan cable connector from the A2 processor assembly to release the fan.

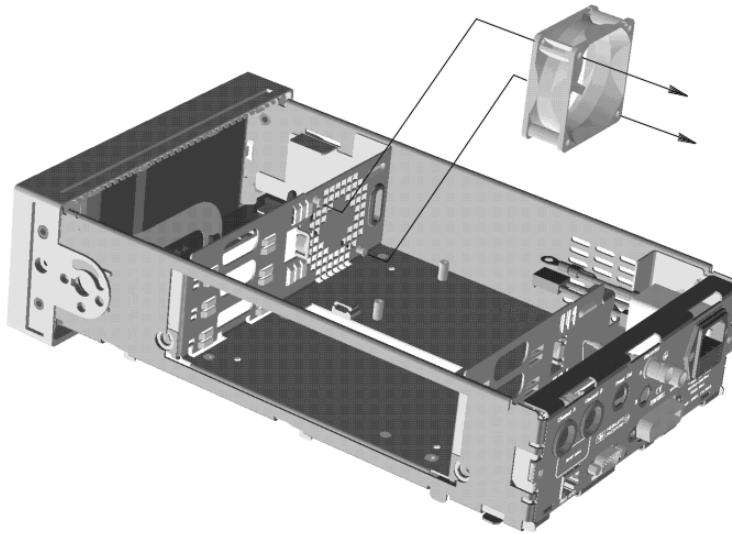

## Removing the Power Meter RAM Battery (BT1)

- 1 Remove the A2 processor assembly as described on [page 109](#).
- 2 Remove the A2J1 link to disconnect the battery from the rest of the circuitry.
- 3 Verify the battery protection circuitry by:
  - Ensuring that there are no electrical short circuits across the battery terminals.
  - Ensuring that there are no voltages present which could apply a charging voltage.
- 4 Once the protection circuit has been verified remove the battery. The battery is siliconed to the assembly. It may be necessary to remove it using a scalpel.
- 5 Store the battery individually in an anti-static (dissipative) bag or suitable non-conductive packaging.
- 6 After replacing the battery secure it using a tie wrap. This should be secured from the top of the A2 processor assembly. The recommended tie wrap part number is 1400-1154.
- 7 Replace the A2J1 link.

**WARNING**

**This power meter uses a lithium battery which may explode if mishandled. The battery should not be subjected to short circuit of the battery terminals or to excessive heat.**

**Do not recharge this battery or dispose of it by burning. Check local country regulatory requirements on the disposal of lithium batteries.**

---

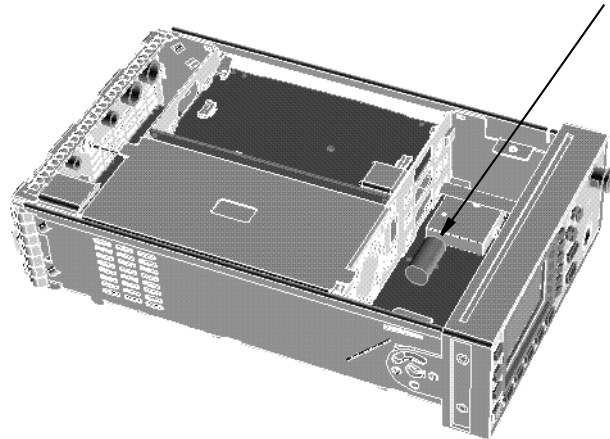

## Removing the A3 Front Panel Assembly

- 1 Disconnect the following cables from the A2 processor assembly:
  - Power reference semi-rigid (When replacing use the torques detailed on [page 120](#)).
  - Front panel keypad.
  - Front panel LCD.

### NOTE

Take care when disconnecting the front panel keyboard and LCD. Move the A2 plastic support bracket to its forward position using the two side levers, unclip the flexi-cable retaining bar on the front panel keypad and front panel LCD cable connectors and disconnect the cable.

- 2 Disconnect the flex circuit from the measurement assembly.

### NOTE

Take care when disconnecting the flex circuit from the measurement assembly.

The flex circuit assembly is released by pushing the connector tab forward and lifting. To replace the flex circuit, loop it as shown on [page 118](#), and connect the flex circuit as shown in the figures on [page 113](#).

- 3 Remove the center screw from the right hand side of the front panel.
- 4 Remove the front panel by pressing in the metal tab on the front panel as shown and push down on the side of the chassis until the standoffs are cleared from the holes.

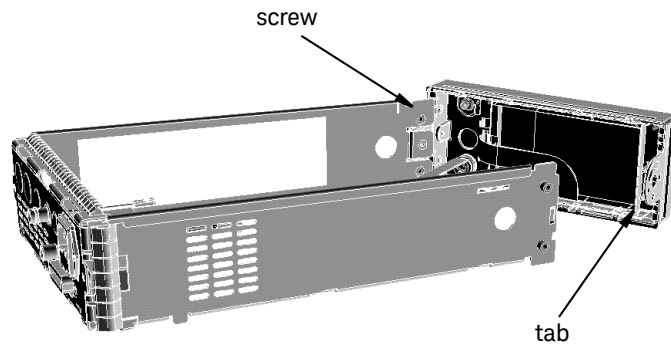
**NOTE**

After replacing a front panel assembly, the display brightness and contrast must be adjusted. Refer to [Chapter 3, "Display Brightness and Contrast Adjustment"](#) for further information.

### Replacing the Front Panel Power Sensor Cable Assemblies

- 1 Remove the front panel from the power meter. (Refer to “**Removing the A3 Front Panel Assembly**” on page 116 for details on removing the front panel).
- 2 Replace the power sensor cable assembly(s) using the replacement kit.

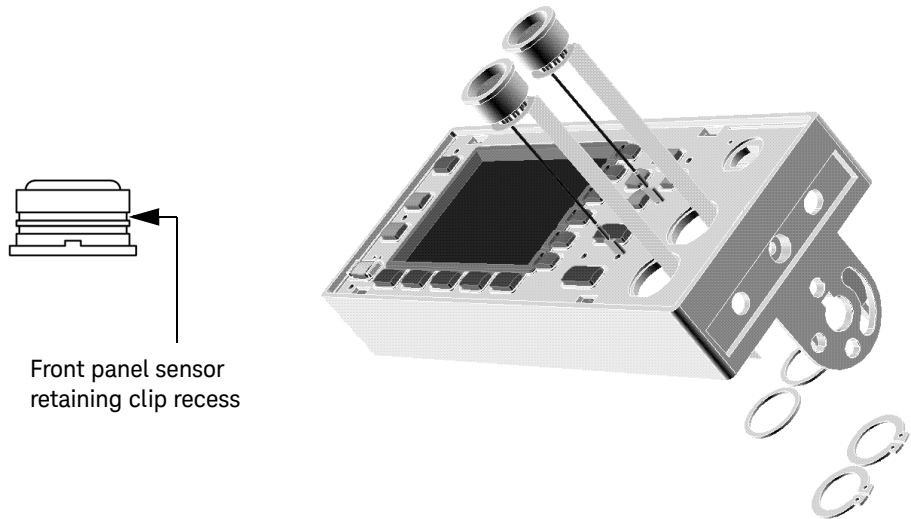

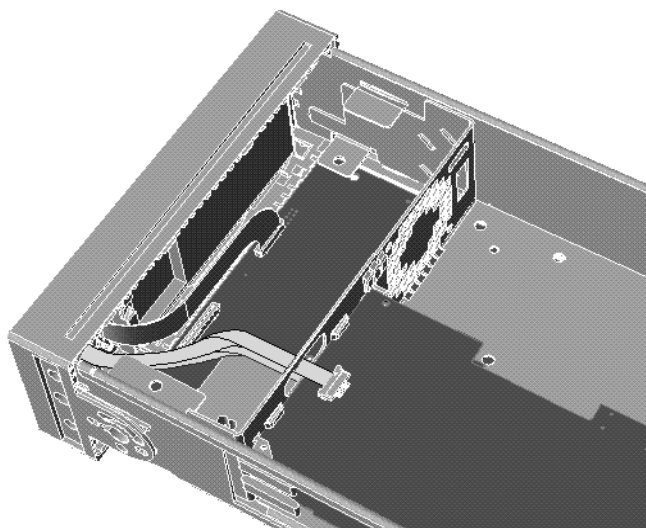
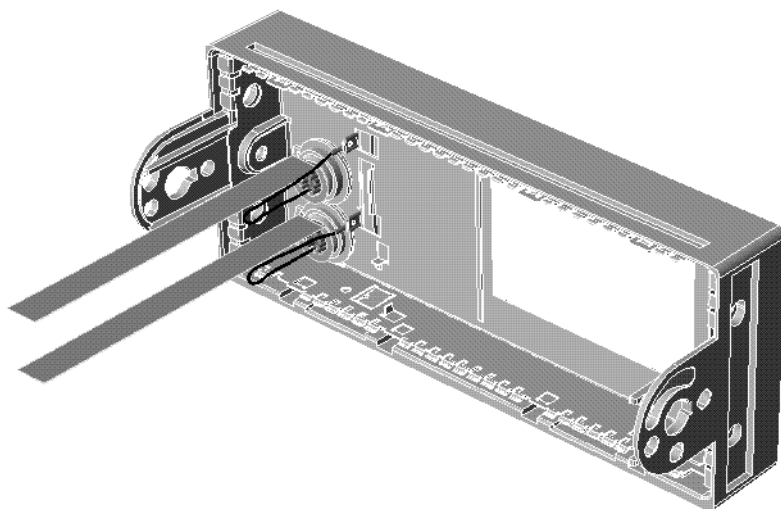

## Replacing the Front Panel Power Reference Cable Assembly

- 1** Remove the front panel from the power meter. (Refer to “**Removing the A3 Front Panel Assembly**” on page 116 for details on removing the front panel).
- 2** Replace the power reference output cable assembly using the replacement kit and the torques indicated on the following diagrams:



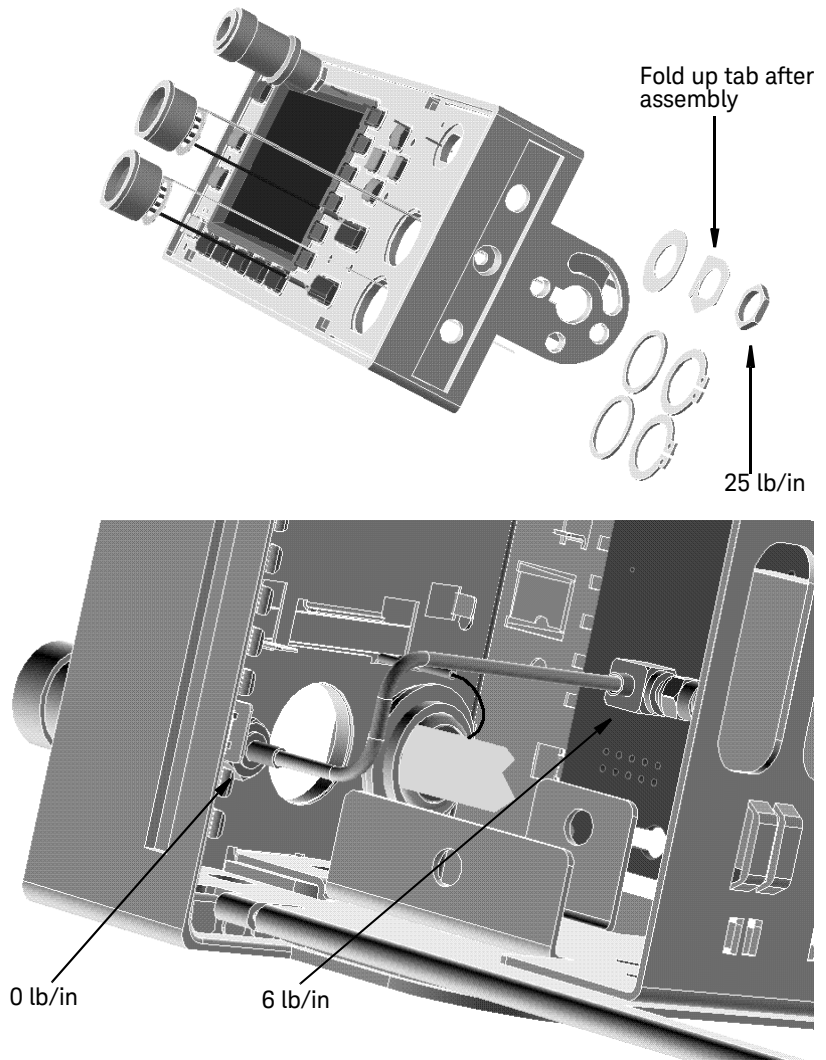

## Replacing the Rear Panel Power Sensor Cable Assemblies (Options 002 and 003)

- 1** Disassemble the power meter to allow access to the rear panel connectors.  
Complete this step by following steps 1 through 3 of the A4 comms assembly removal procedure on [page 111](#).
- 2** Replace the power sensor cable assembly using the replacement kits.  
The inner recess on the power sensor cable is used to locate the circlip when assembling to the rear chassis.

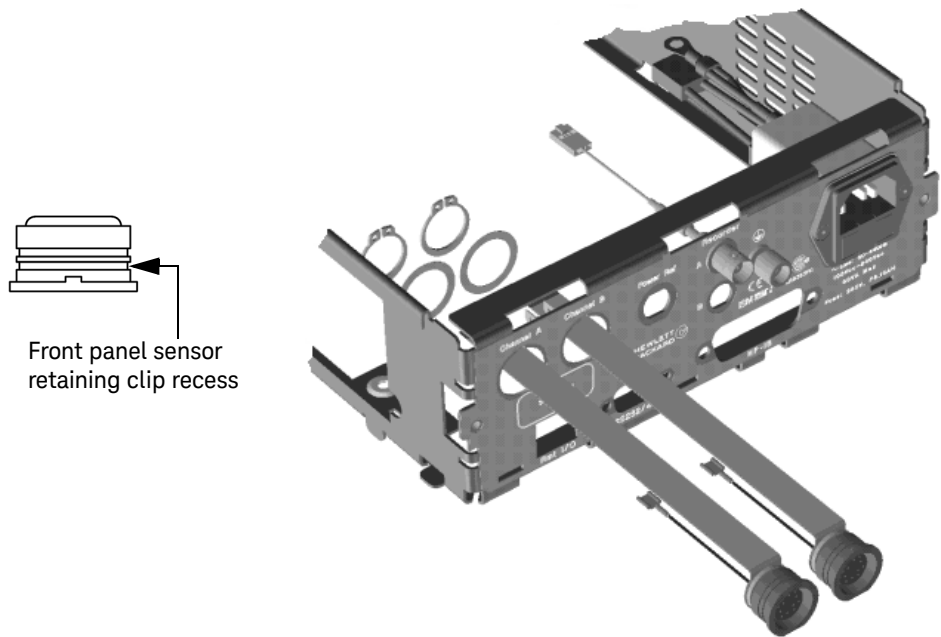

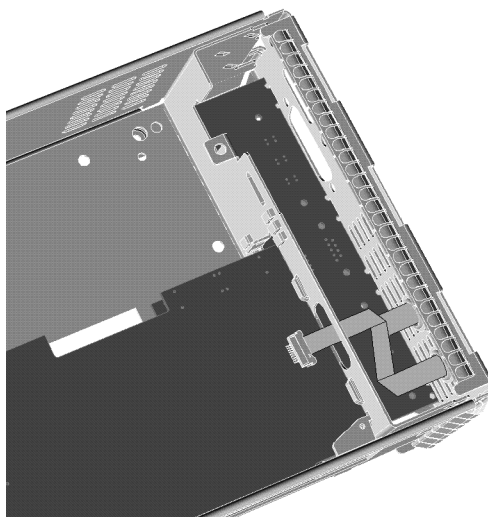
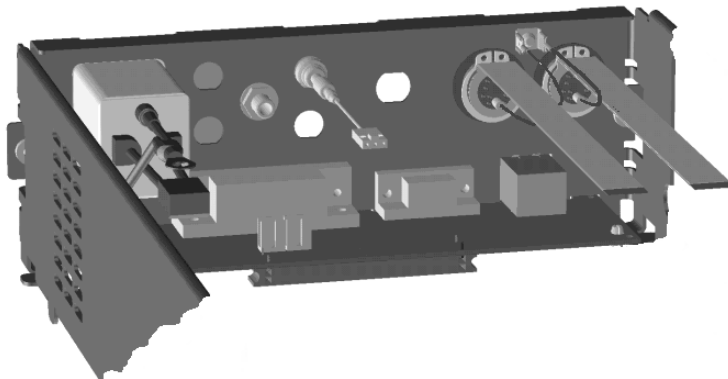

## Replacing the Rear Panel Power Reference Cable Assembly (Option 003)

- 1 Disassemble the power meter down to allow access to the rear panel connectors. (Refer to **“Removing the A4 Comms Assembly”** on page 111 for further information).
- 2 Replace the power reference cable assembly using the replacement kit and the torques indicated on the following diagrams:

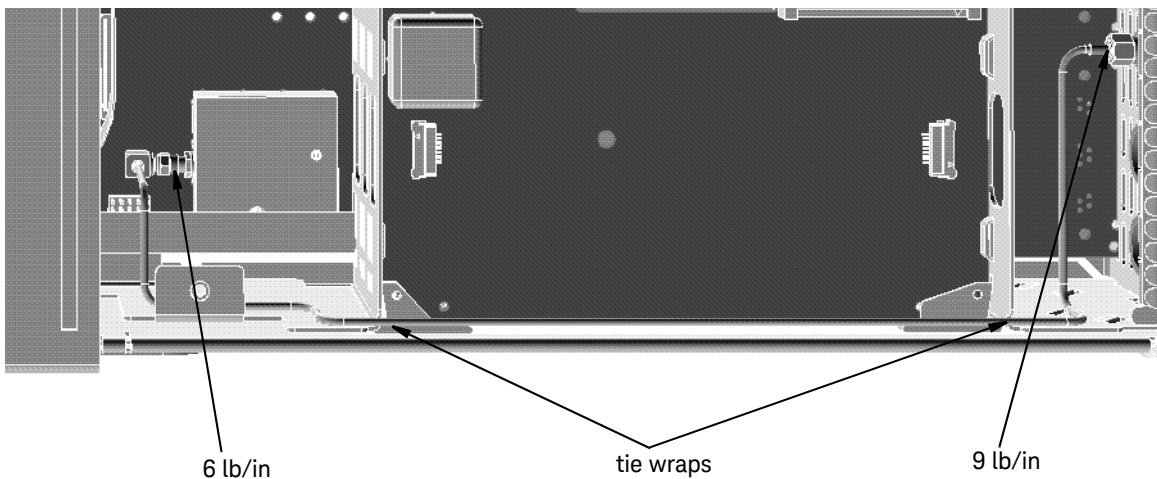
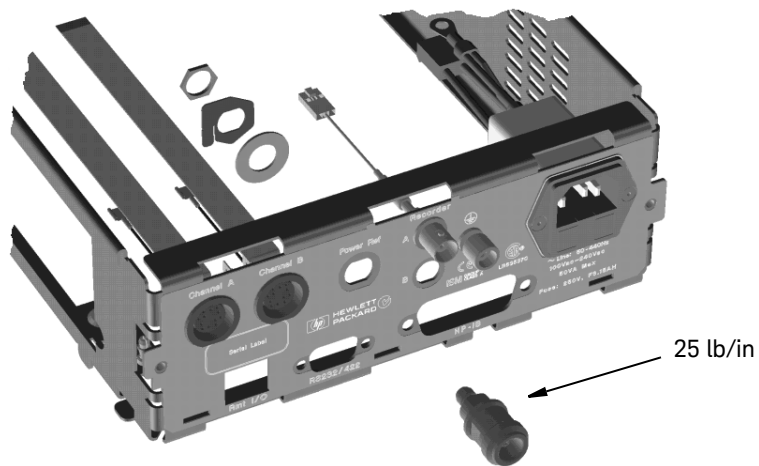

## Replacing the Rear Panel Recorder Output(s) Cable Assembly

- 1 Disassemble the power meter down to allow access to the rear panel connectors. (Refer to “[Removing the A4 Comms Assembly](#)” on page 111 for further information).
- 2 Replace the recorder output cable assembly using the replacement kit and the torque indicated on the following diagram:

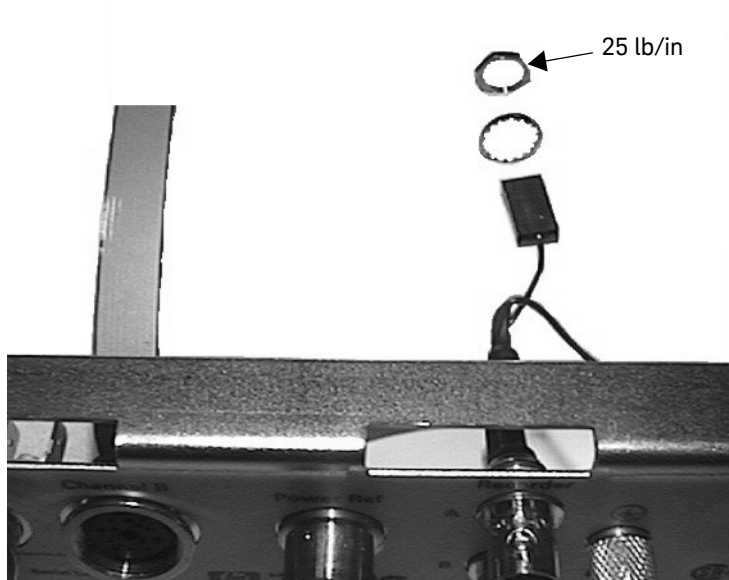
**NOTE**

Recorder output A connects to A4 J23 and recorder output B connects to A4 J24.

## Replacing The Chassis Assembly

- 1 Remove the Power Meter Cover as shown in “[Removing the Power Meter Cover](#)” on page 107.
- 2 Disassemble the power meter down to allow access to the rear panel connectors (Refer to “[Removing the A4 Comms Assembly](#)” on page 111).
- 3 For Standard or Option #002 models, disconnect the Power Reference Cable from the Front Panel Assembly.
- 4 For Option #003 units, disconnect the Power Reference Cable from the Chassis Assembly (rear panel).
- 5 Remove the A3 Front Panel Assembly as shown in “[Removing the A3 Front Panel Assembly](#)” on page 116.
- 6 For Option #002 or Option #003 models, remove the Rear Panel Power Sensor Cable Assemblies as shown on “[Replacing the Rear Panel Power Sensor Cable Assemblies \(Options 002 and 003\)](#)” on page 122.
- 7 For Option #003 units, remove the Rear Panel Power Reference Connector as shown on “[Replacing the Rear Panel Power Reference Cable Assembly \(Option 003\)](#)” on page 124.
- 8 Remove the Recorder Output(s) Cable Assembly as shown on “[Replacing the Rear Panel Recorder Output\(s\) Cable Assembly](#)” on page 125.
- 9 Remove all blanking plugs from the rear panel.
- 10 Obtain the new Chassis Assembly, and then re-assemble the Power Meter by following steps 1 to 9 in reverse order.

### WARNING

**When replacing the power supply unit in the power meter, ensure that all earth wiring is reconnected. There are two terminals to check, the first is the force fit connector to the power supply unit and the second a closed loop terminal bonded to the chassis with an M3.5 machine screw (use a 9 lb/in T15 screw driver). All the protective earth wiring can be identified by the insulation color green with a yellow stripe.**

---

### WARNING

**Once re-assembly is complete, the unit must be safety-tested in accordance with local guidelines and procedures. This safety-test may take the form of an Earth Continuity Test, Hi-Pot Test, etc.**

---

# 6 Troubleshooting

Introduction 128

## Introduction

This chapter enables qualified service personnel to diagnose suspected faults with the power meter Rmt I/O (Remote Input/Output) signal lines and RS232/422 serial port.

If there is a problem when attempting to use the RS232/422 serial interface or the remote I/O functions, consult the User's Guide and confirm that all the user setups are correct before proceeding with the following fault finding flow charts.

### Suggested Diagnostic Equipment

- 1** Digital multi-meter capable of measuring voltage and resistance, for example, Keysight E4975.
- 2** Signal source capable of producing 300 ms TTL single shot pulses, for example, Keysight 33120A.
- 3** +5 V TTL logic level source.
- 4** RS232 self test connector – 9 way 'D' type female connector with the following pins wired together:
  - Pin 2 (Rx)to Pin 3 (Tx).
  - Pin 4 (DTR)to Pin 6 (DSR).
  - Pin 7 (RTS)to Pin 8 (CTS).
- 5** RS422 self test connector - 9 way 'D' type female connector with the following pins wired together:
  - Pin 1 (CTS–)to Pin 9 (RTS–).
  - Pin2 (Rx–)to Pin 4 (Tx–).
  - Pin 3 (Tx+)to Pin6 (Rx+).
  - Pin7 (RTS+)to Pin 8 (CTS+).



- 6** 8 way RJ45 plug with flying leads wired to pins 2, 3, 4, 5 and 6 to apply and monitor signals on the remote TTL I/O connector.
- 7** GPIB controller and cable - required to apply "\*RST" command through the rear panel GPIB connector.

**NOTE**

In the following flowcharts a bold font indicates the label of a soft/hard key the user must select.

---

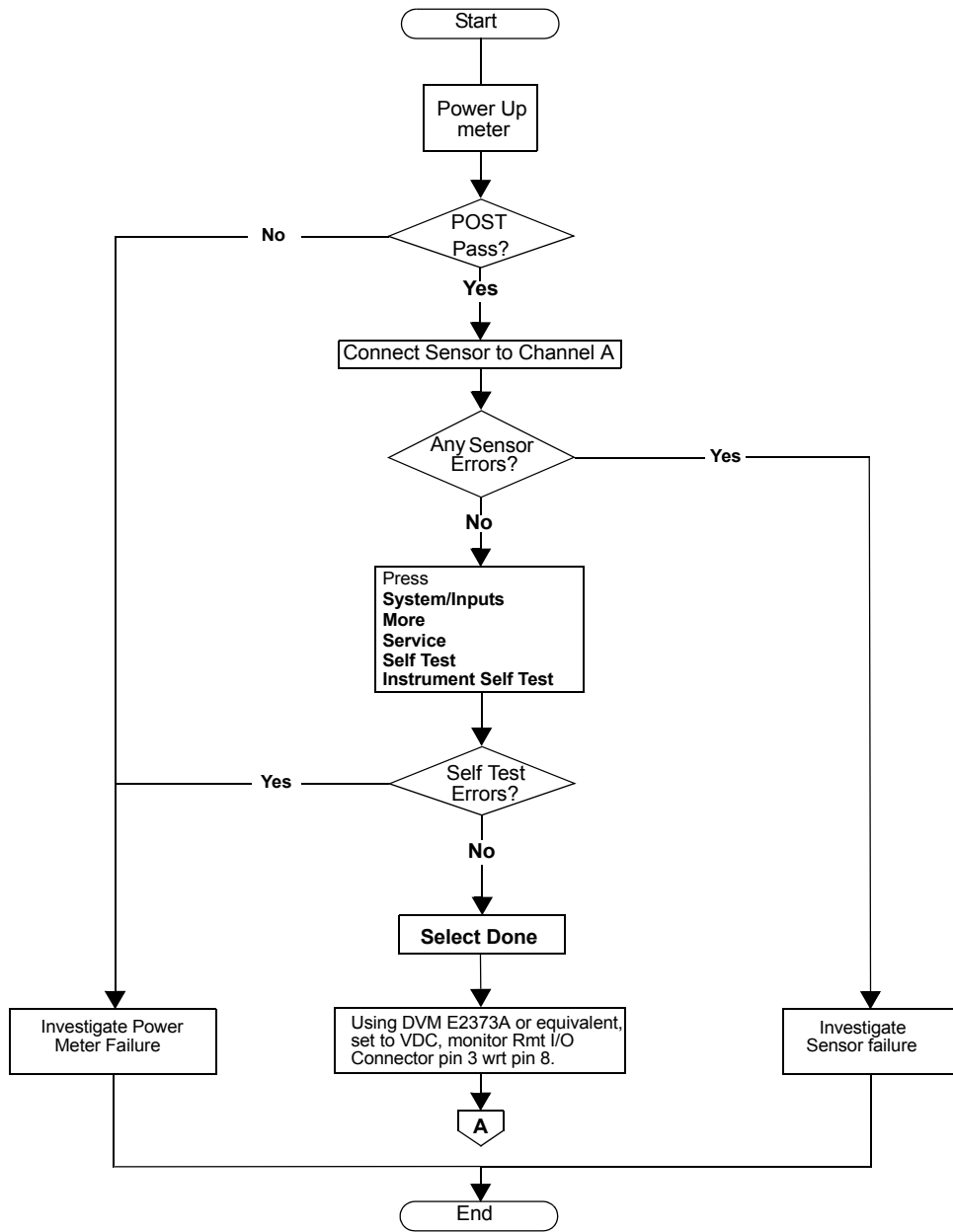

**Figure 6-1** Troubleshooting Guide - TTL Output 1

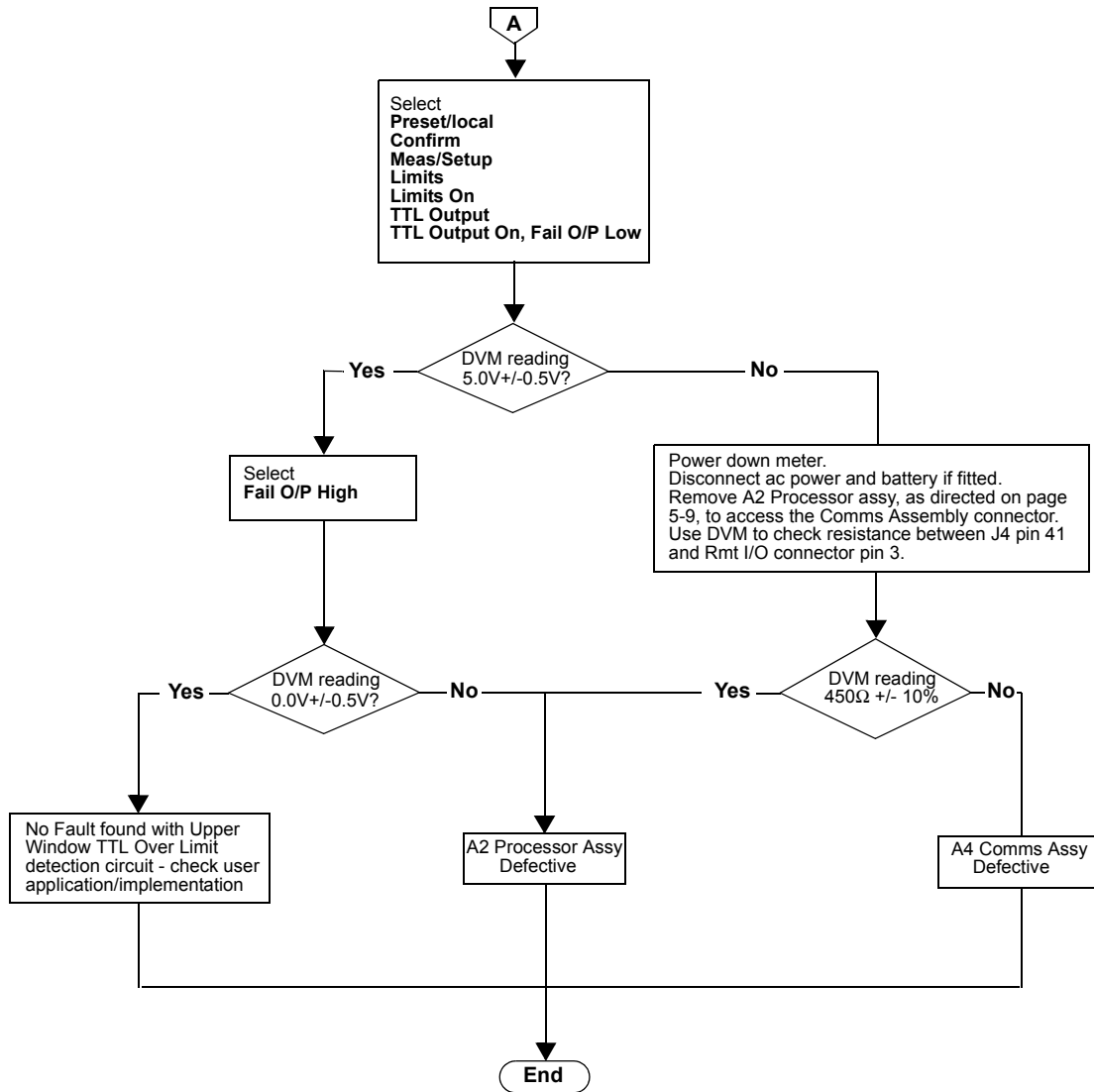

Figure 6-2 Troubleshooting Guide - TTL Output 1 (continued)

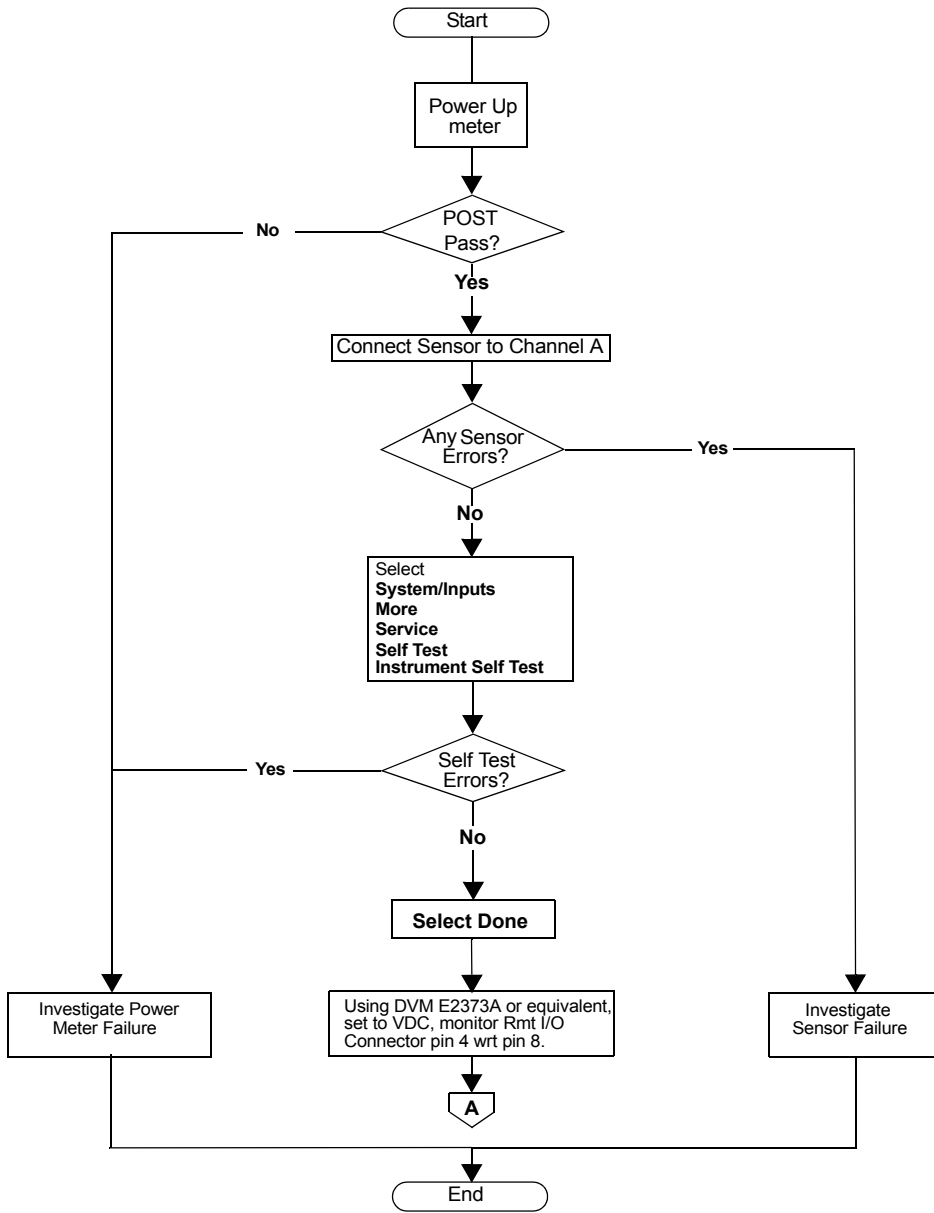

Figure 6-3 Troubleshooting Guide - TTL Output 2

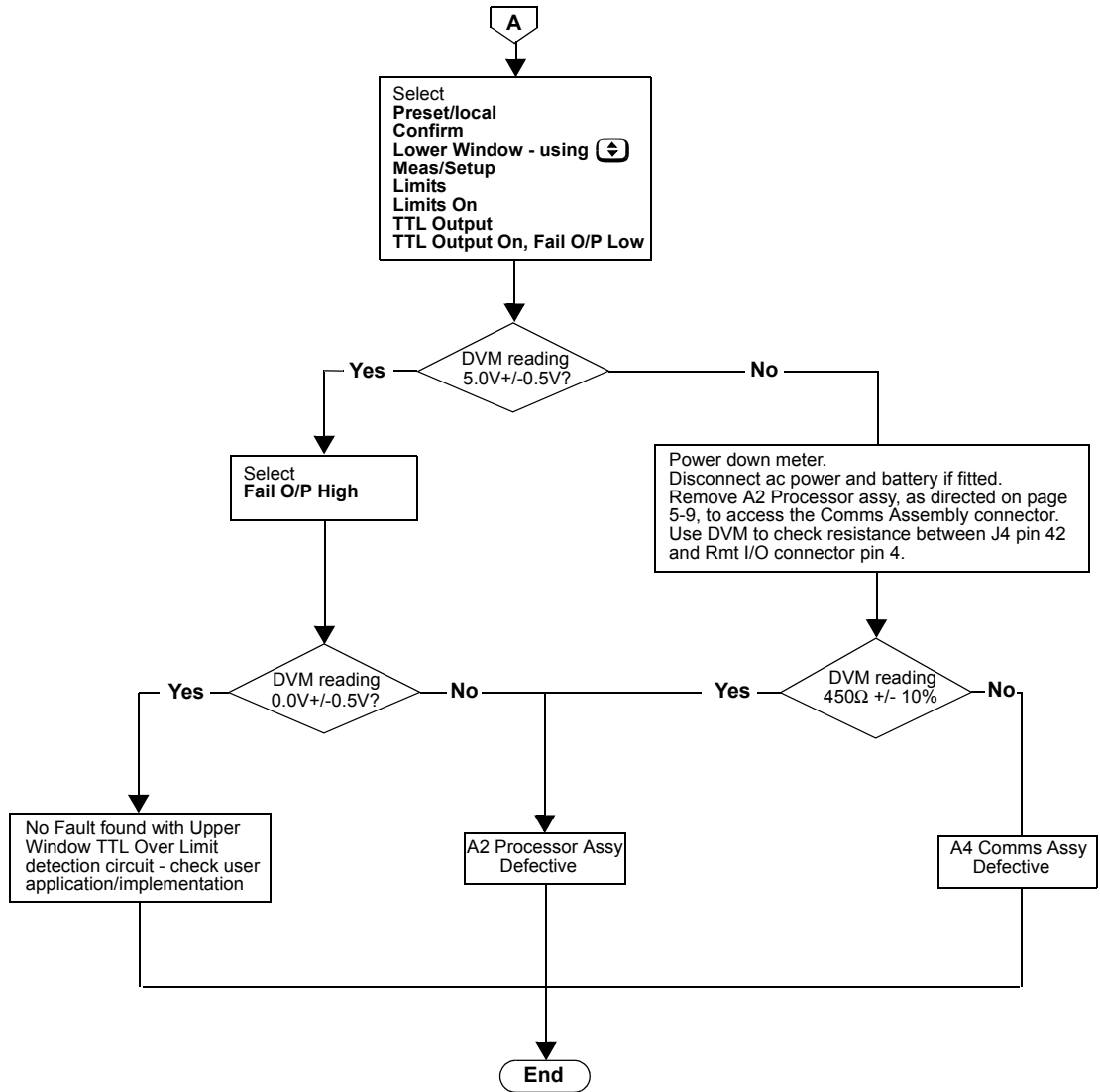

Figure 6-4 Troubleshooting Guide - TTL Output 2 (continued)

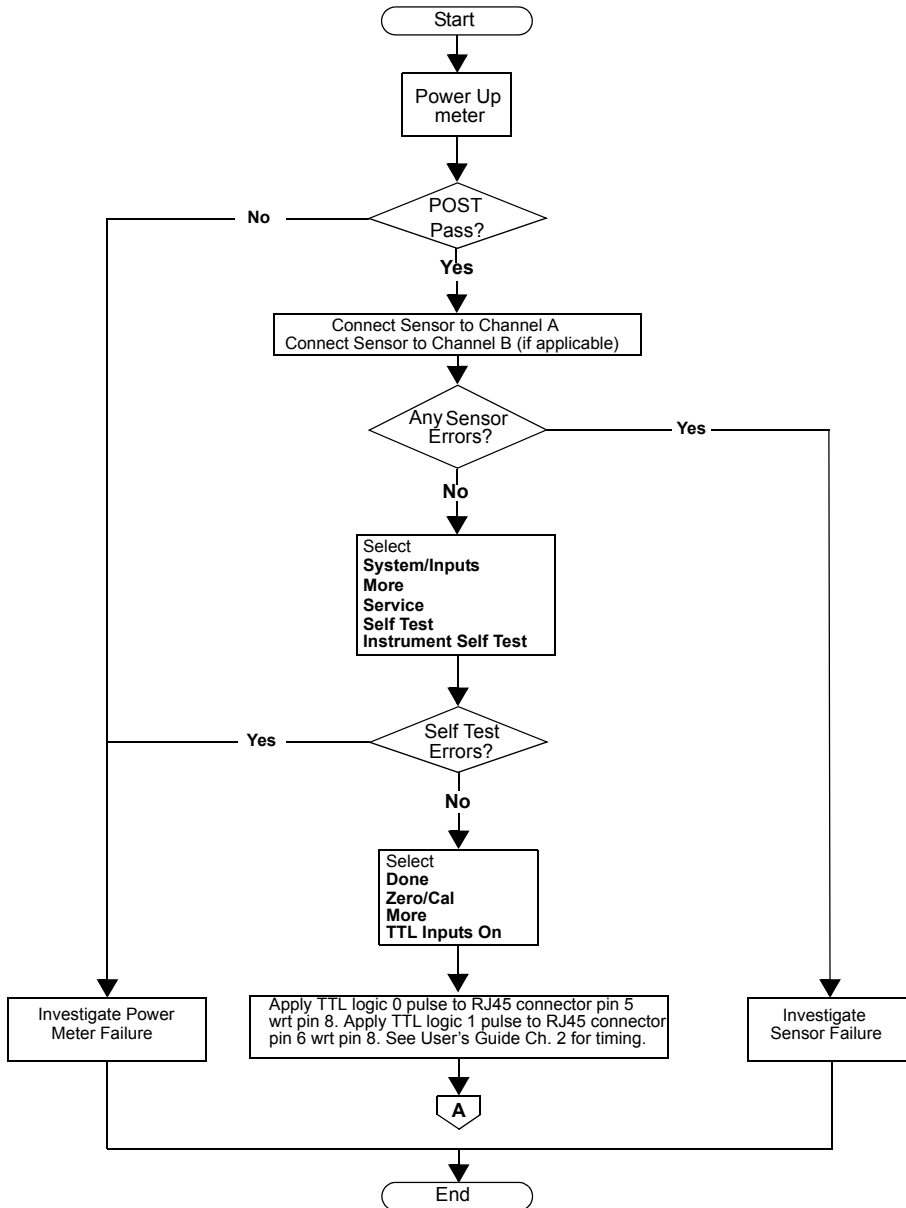
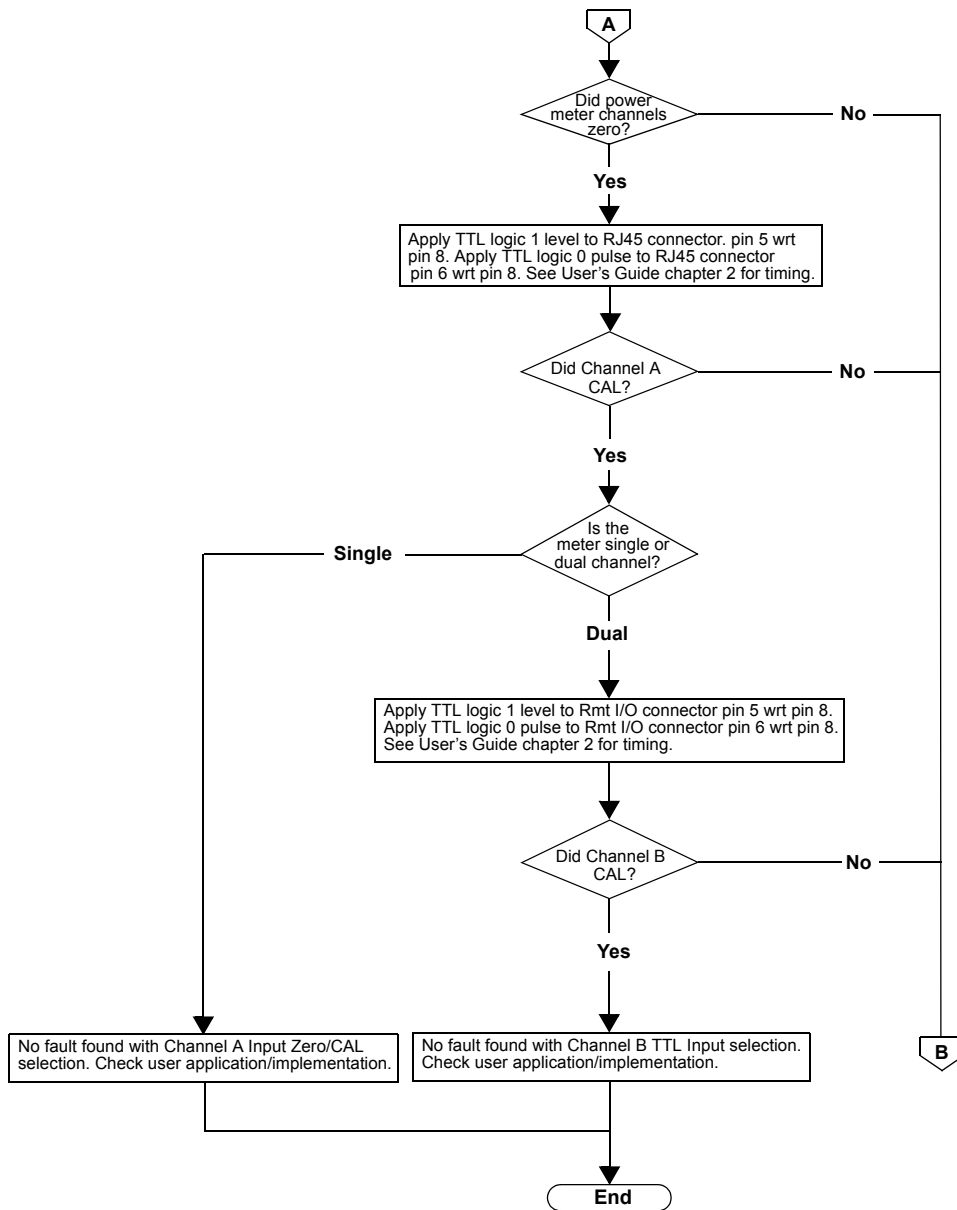

Figure 6-5 Troubleshooting Guide - TTL Inputs



**Figure 6-6** Troubleshooting Guide - TTL Inputs (continued)

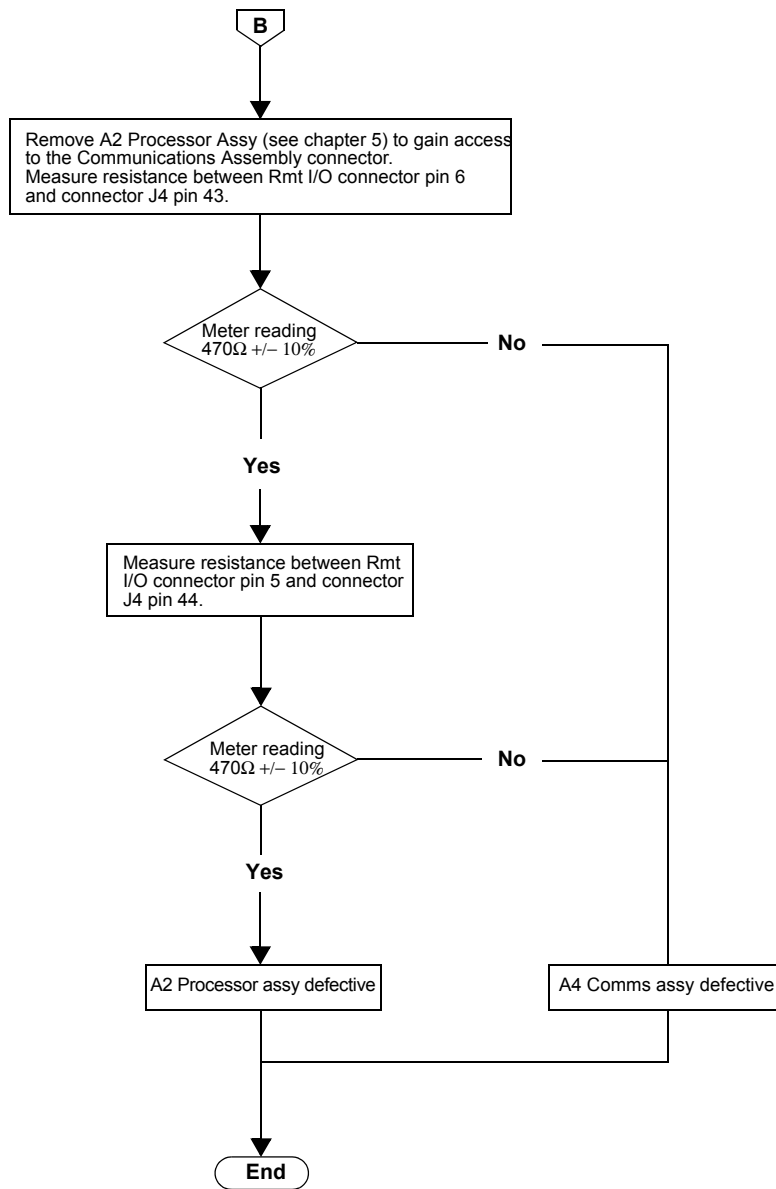

Figure 6-7 Troubleshooting Guide - TTL Inputs (continued)



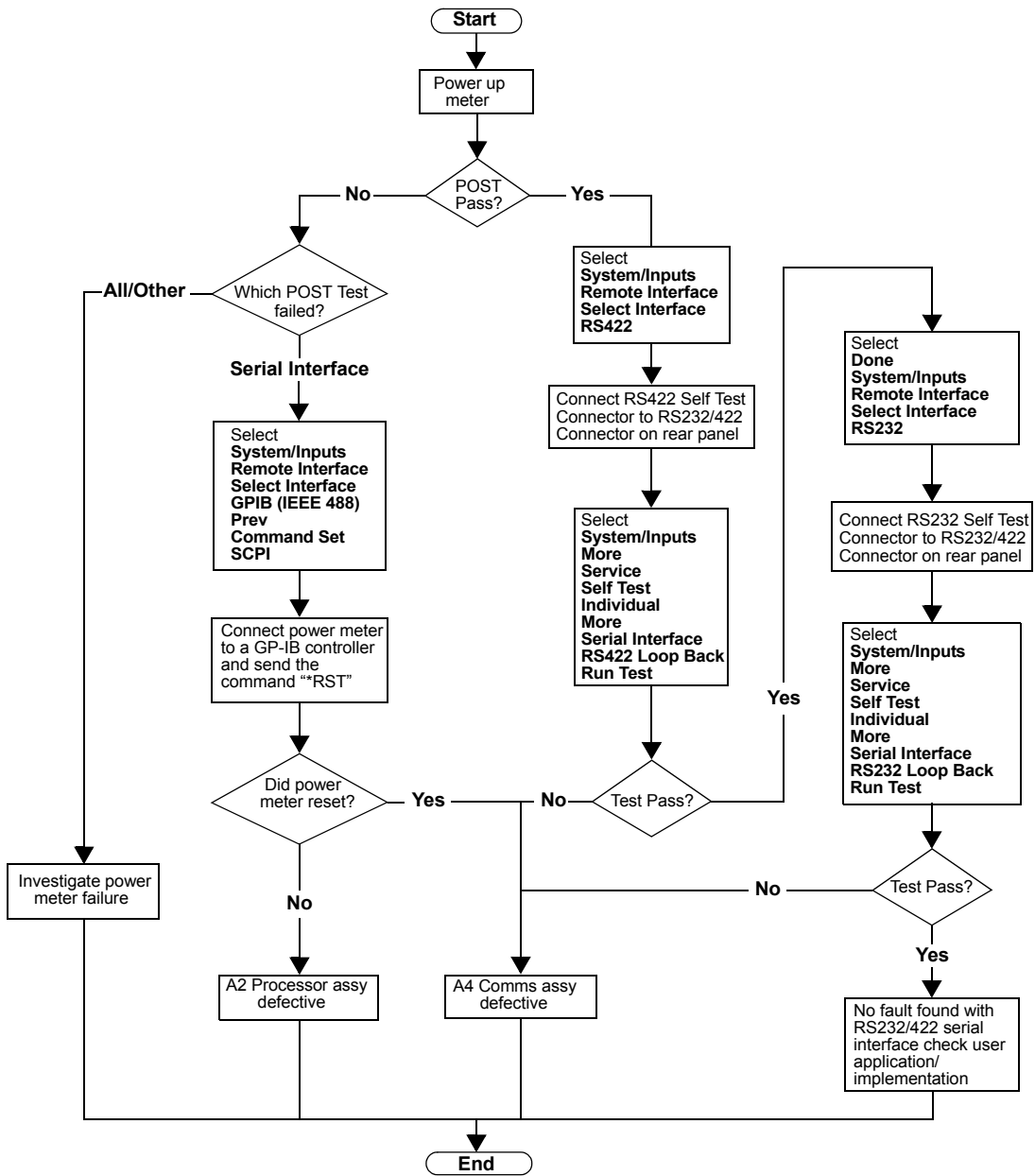

Figure 6-8 Troubleshooting Guide - RS232/422 Interface

THIS PAGE HAS BEEN INTENTIONALLY LEFT BLANK.

# A Keysight 432A Power Meters & 478A Sensors: Additional Information

Keysight 432A Power Meters: Additional Information	140
Keysight 478A Sensors: Additional Information	141

## Keysight 432A Power Meters: Additional Information

The internal bridge resistance of the Keysight 432A can be set to either 200  $\Omega$  or 100  $\Omega$ . It is important that this value is measured accurately (rounded to the nearest 0.01  $\Omega$ ) and recorded for use in the following tests:

- Power Reference Level Test.
- Output Standing Wave Ratio (SWR) Test.

Before attempting to measure the internal bridge resistance of the Keysight 432A, verify that no power is applied to the unit. Connect a DVM (set to measure resistance) between the VRF connector on the rear panel of the Keysight 432A and pin 1 on the thermistor mount end of the sensor cable. The Keysight 432A front panel MOUNT RESISTANCE switch determines which bridge resistance is selected.

For reference only, typical bridge resistance values are as follows:

- $R_{200} \equiv 200.05 \Omega$
- $R_{100} \equiv 100.25 \Omega$

### NOTE

Using incorrect resistance values in these calculations will introduce significant errors.

---

## Keysight 478A Sensors: Additional Information

The Voltage Reflection Coefficients (VRC) of the Keysight 478A sensor must be known before attempting to perform the Output Standing Wave Ratio (SWR) Test. The VRC values required for this test are as follows:

- Frequency 50 MHz, with the mount resistance of the Keysight 432A set to 200 (recorded as  $|\Gamma_1|$ ).
- Frequency 50 MHz, with the mount resistance of the Keysight 432A set to 100 (recorded as  $|\Gamma_2|$ ).

For reference only, typical values of these VRC values are as follows:

- $|\Gamma_1| \cong 0.0012$
- $|\Gamma_2| \cong 0.3317$

**NOTE**

Using incorrect VRC values in the Output SWR calculations will introduce significant errors.

---

THIS PAGE HAS BEEN INTENTIONALLY LEFT BLANK.

# B Equipment Required For Performance Tests And Adjustments

Summary Table [144](#)

## Summary Table

The following table summarizes the equipment required for all performance tests (P) and adjustments (A). If alternative equipment is used it must meet the critical specifications shown in the table.

**Table B-1** Equipment Required For Performance Tests And Adjustments

Equipment Required	Model Number	Critical Specification	Usage
Digital Multimeter	Keysight 3458A	Range 0 to 20 V Resolution 0.01 mV	P and A
DC Calibrator	Datron 4000A or Fluke 5700A/5720A		P
Range Calibrator	Keysight 11683A or Keysight 11683A Opt H01	Option H01 is essential for accurate verification. (See analysis in <a href="#">Appendix D</a> . The Standard 11683A can be used for indication only.	P
Frequency Calibrator	Keysight 53132A	Range 0.1Hz to 225 MHz Resolution 0.01 Hz	P and A
Power Meter	Keysight 432A	Range 1 mW Transfer Accuracy 0.2% Internal bridge resistance must be known for 100 $\Omega$ and 200 $\Omega$ settings. For further information refer to <a href="#">Appendix A</a> .	P and A
Thermistor Mount	Keysight 478A Opt H75/H76 or Keysight 8478B Opt H01	SWR<1.05 at 50 MHz Accuracy $\pm$ 0.2% at 50 MHz VRC must be known for thermistor bridge settings of 100 $\Omega$ and 200 $\Omega$ . For further information refer to <a href="#">Appendix A</a> .	P and A
Power Sensor	E9321A		P
30 dB Attenuator	Keysight 11708A or Keysight 8491A Opt 030		P



**Table B-1** Equipment Required For Performance Tests And Adjustments (continued)

Equipment Required	Model Number	Critical Specification	Usage
Power Sensor Cable 2 required	E9288A		P and A
Breakout Box Kit	E9288AZ Option K01		P

B Equipment Required For Performance Tests And Adjustments

THIS PAGE HAS BEEN INTENTIONALLY LEFT BLANK.

# C Measurement Uncertainty Analysis – Power Reference Level Test

Measurement Introduction 148

## Measurement Introduction

In the Power Reference Level Test, the output from the DUT's 1mW Power Ref connector is measured.

A Keysight 432A Power Meter and an 8478B H01 Power Sensor are required for this test. Also the H01 power sensor's calibration factor uncertainty at 50 MHz must be no greater than  $\pm 0.2\%$ .

A Keysight 3458A DMM is required to read the  $V_{ref}$  and  $V_{comp}$  outputs of the Keysight 432A. This is preferred to estimating an inaccurate visual reading from the Keysight 432A front panel.

### Define the Measurand

The measurand is the output power of the 1mW reference in the DUT.

### Define the Measurement Equation

$$P_{meas} = \frac{2 \cdot V_{comp} \cdot (V_1 - V_0) + V_0^2 - V_1^2}{4 \cdot R \cdot CF \cdot M_S}$$

where,

$V_0$  is the voltage measured between  $V_{comp}$  and  $V_{ref}$  with no power applied, for example, the reference switched off and after the Keysight 432A has been zeroed.

$V_1$  is the voltage measured between  $V_{comp}$  and  $V_{ref}$  with power applied, for example, the reference switched on.

$V_{comp}$  is the voltage between the 432A  $V_{comp}$  rear connector and chassis ground with power applied.

R is mount resistance of the 432A meter.

CF is the value of the Calibration Factor of the Thermistor mount at 50 MHz.

$M_s$  is the mismatch magnitude between the DUT reference and the 8478B sensor, which is equal to:

$$M_s = 2 \cdot P_s \cdot P_d$$

where,

$P_s$  is the reflection coefficient of the source (i.e. the DUT) and  $P_d$  is the reflection coefficient of the 8478B detector.

Hence,

$$P_{meas} = f(V_{comp}, V_1, V_0, R, CF, M_s)$$

Consider the measurement setup that exists in [Table C-1](#)

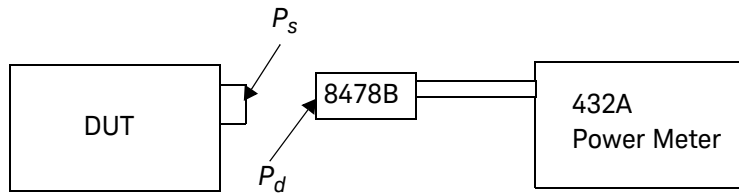

**Figure C-1** Measurement Setup

$P_o$  is the total power output from the DUT. Of this power a proportion related to  $P_d$  is reflected back towards the source. The power subjected on the Keysight 432 would be:

$$P_o(1 - P_d^2)$$

But because a proportion of this total power related to  $P_d$  has been reflected  $P_s$  will again cause a reflection giving:

$$P_o(1 \pm P_s P_d)^2$$

So the total power incident or measured by the Keysight 432 Power meter is given by:

$$(P_o(1 - P_d^2)) / \left| (1 \pm P_s P_d)^2 \right|$$

**NOTE**

In all cases  $P_d$  is extremely small therefore  $P_d^2$  terms tend to zero leaving.

---

$$M_s \text{ Uncertainty} = 1 / (1 \pm 2P_s P_d)$$

The equation above includes the worst-case mismatch magnitude  $2P_s P_d$  and is in the form where various powers can be multiplied by the equation to find worst-case power levels with respect to mismatch.

**NOTE**

From the above mismatch uncertainty equation if  $P_d$  is zero, for example, the 8478B sensor is exactly 50 ohms then there is NO mismatch uncertainty. This has not yet been achieved but efforts will be made in the future to try to achieve as near as possible to a 'zero' level of mismatch uncertainty and hence have negligible mismatch when calibrating products.

---

## Uncertainty Equation

General form of uncertainty equation is:

$$u^2(y) = \sum_{i=1}^N c_i^2 u^2(x_i) + 2 \left( \sum_{i=1}^N \sum_{j=i+1}^N c_i c_j u(x_i, x_j) \right)$$

Hence,

$$u^2(1mW) = |C_{V_0} \cdot u(V_0)|^2 + |C_{V_0} \cdot u(V_0)|^2 + |C_{V_{comp}} \cdot u(V_{comp})|^2 + |C_R \cdot u(R)|^2 + \dots \\ |C_{CF} \cdot u(CF)|^2 + |C_{M_s} \cdot u(M_s)|^2 + |C_{Rep} \cdot u(Rep)|^2 + |C_{Drift} \cdot u(Drift)|^2$$

Assuming that there is no correlation exists between the 8 input variables.

## Voltage Measurements Uncertainty

Since the manufacturer's data is used to determine the standard uncertainty, the analysis used is the Type A method.

The 3458A DMM Uncertainty is calculated with reference to the *Appendix A* of the 3458A Operating Manual.

A normal distribution is assumed, as the 3458A Manual has not specified the type of distribution used on the measurement.

Both  $V_0$  and  $V_1$  values are calculated by subtracting  $V_{ref}$  from  $V_{comp}$  as measured at the output of the 432A using a 3458A DMM. The approximate values of  $V_{comp}$  and  $V_{ref}$  for no power ( $V_0$ ) and for 1 mW power ( $V_1$ ) are 5 V with the DMM on the 10 V scale.

For the 3458A DMM, the specified accuracy for the 10 volt scale is: 8ppm of Reading + 0.5 ppm of Range

C Measurement Uncertainty Analysis - Power Reference Level Test

with;

0.15 ppm of Reading + 0.01 ppm of Range per °C (temp coefficient Tcal ±5 °C)  
 ± 8.75 ppm of Reading + 0.55 ppm of Range

Therefore,

$$U(V_{comp}) = U(V_{ref}) = \pm \left[ \frac{8.75 \times 5}{1000000} + \frac{0.55 \times 10}{1000000} \right] = \pm 49.25 \mu V$$

For  $V_0$  and  $V_1$ , two measurements are taken, so the uncertainty is equated to the RSS of using two DMMs;

Voltage measurement	Uncertainty
$U(V_{comp})$	49.25 $\mu V$
$U(V_0)$	69.65 $\mu V$
$U(V_1)$	69.65 $\mu V$



## Mismatch

The Mismatch uncertainty was previously determined as being:

$$M_S \text{ Uncertainty(magnitude)} = 2P_S P_d$$

### NOTE

This is the worst-case uncertainty for mismatch and occurs when the incident and reflected waves are 180 degrees out of phase

Consider the model below:

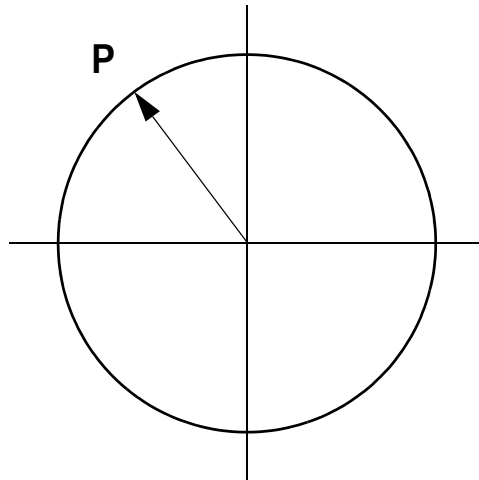

An estimate of the moduli of  $P_d$  and  $P_s$  are each less than a specified value.  $P_s$  and  $P_d$  each lie within a circle of radius  $P$ . Assuming  $P_d$  and  $P_s$  have equal probability of lying anywhere within the circle the standard uncertainty of Mismatch becomes

$$u(M_S) = \pm \frac{\max P_s \cdot \max P_d}{\sqrt{2}}$$

$P_s$  is the reflection coefficient of the source, which is specified as less than 1.05.

$$VSWR < 1.05$$

## C Measurement Uncertainty Analysis - Power Reference Level Test

The reference is designed to have a VSWR of less than 1.05.

$$VSWR < 1.05$$

Hence,

$$P_S(max) = P_D(max) = \frac{VSWR - 1}{VSWR + 1} = \frac{1.05 - 1}{1.05 + 1} = 0.0244$$

So  $u(M_S)$  from the equation above equals:

$$u(M_S) = \pm \frac{(0.0244) \times (0.0244)}{\sqrt{2}} = 0.00042$$

Mismatch Uncertainty  $U(M_S)$  worst case:

$$UM_S = 2P_S P_D = 2\sqrt{2} \times u(M_S) = 0.0012$$

## Calibration factor

The calibration factors supplied with the power sensor take into account the performance of the sensor with respect to frequency. This value is of secondary importance when calculating the overall uncertainty of the 1 mW reference.

The information that is appropriate is the Uncertainty of the Calibration Factor. The power sensor must be calibrated such that:

$$\text{Uncertainty of Calibration Factor} < 0.2\%$$

Therefore,

$$U(CF) = 0.002$$

## Sensor Calibration Factor Drift

The Keysight Standards Laboratory at South Queensferry has determined the following average sensor drift value.

Average Sensor Drift < 0.06% per year

Therefore,

$U(\text{Drift}) = 0.0006$

### NOTE

This value is only valid for 8478B sensors calibrated to 0.2% accuracy.

---

## Resistance

The uncertainty of the resistance measurement on the 3458A DMM is given from:

Error = (ppm of reading + ppm of range) + (temperature coefficient) + (factory traceability)

with: -

**Conditions:** 1 Year Cal and temperature variance +/- 5 °C without ACAL

**Reference:** *Keysight 3458A Operating Manual Appendix A*

For 1 k $\Omega$  scale the specified accuracy is;

10 ppm of reading + 0.5 ppm of range

with: -

1 ppm of Reading + 0.1 ppm of Range per °C (temp coefficient Tcal  $\pm 5$  °C)  
and, 3 ppm of Reading (for factory traceability)

Therefore,

$$U(R) = \left[ \frac{200 \times (10 + 5 + 3)}{1000000} + \frac{1000 \times (0.5 + 0.5)}{1000000} \right]$$

$$= (0.0036 + 0.0010)$$

$$= 0.0046 \Omega$$

### Repeatability

To verify the overall repeatability of the measurement, the test was repeated 20 times, using the same DUT. For each test cycle, the Power Reference Level Test and the Power Reference Level Adjust tests, were carried out; at no point during these tests was the 1mW on the DUT adjusted. The thermistor was disconnected and reconnected between each test with the sensor position rotated each time. The results for this evaluation are shown in [Table C-1](#).

**Table C-1 Measurement Repeatability Results**

Measurement	ADJUST REF.	REF. LEVEL TEST
1	0.999548951	0.999499495
2	0.999541333	0.999554257
3	0.999449078	0.999414037
4	0.999546994	0.999509401
5 <sup>[a]</sup>	0.999138526	0.9991726
6	0.999647055	0.999454911
7	0.999539391	0.999515949
8	0.999567191	0.999558795
9	0.999600963	0.999554633
10	0.999405584	0.999377721
11	0.999523392	0.999566084
12	0.999504386	0.999504323
13	0.999443652	0.999463611

**Table C-1** Measurement Repeatability Results (continued)

Measurement	ADJUST REF.	REF. LEVEL TEST
14	0.999513893	0.999553753
15	0.999589288	0.999496811
16	0.999485404	0.999529486
17	0.999559381	0.999534985
18	0.999524217	0.99948097
19	0.999523013	0.999518899
20	0.999534276	0.999488886
<b>Max</b>	<b>0.999647</b>	<b>0.999566084</b>
<b>Min</b>	<b>0.999406</b>	<b>0.999377721</b>
<b>Average</b>	<b>0.999529</b>	<b>0.999504053</b>
<b>SD</b>	<b>5.67E-05</b>	<b>5.01868E-05</b>

[a] Measurement 5 was discounted from the calculations as being an extraneous measurement.

The readings in [Table C-1](#) are in milli-Watts, therefore the Standard Deviation (worse case) is: - **U (Rep) = 0.057 mWatts**

## Sensitivity Coefficients (Ci)

$$I \text{ mW Power Measured} = f(V_{\text{comp}}, V_1, V_0, R, CF, M_s)$$

The sensitivity coefficients should be evaluated using the best estimate of  $V_{\text{comp}}$ ,  $V_1$ ,  $V_0$ ,  $R$ ,  $CF$  and  $M_s$ . The nominal values for  $V_{\text{comp}}$ ,  $V_1$ ,  $V_0$ ,  $R$ , and  $CF$  are:

$$V_{\text{comp}} = 4.857 \text{ V}$$

$$V_1 = 83.12 \text{ mV } V_0 = 96.17 \text{ V}$$

$$R^{[1]} = 200$$

$$CF^{[2]} = 97.5\%$$

$$= 0.975$$

The best guess for the Mismatch of the  $P_s P_d$  is = 1. Output power of the source as shown earlier is:

$$(M_s = P_{\text{out}}(1 \pm (2 \cdot P_s \cdot P_d))) \approx 1$$

This equation shows that if an infinite amount of readings of mismatch were taken between  $P_s P_d$  the mean value would equal 1.

Using the above values gives

$$C_{i_{V_{\text{comp}}}} = \left[ \frac{d}{dV_{\text{comp}}} \right]_{PM} = \frac{2(V_1 - V_0)}{4RCFM_s} = 2.129 \times 10^{-4} \frac{\text{V}}{\Omega}$$

$$C_{i_{V_1}} = \left[ \frac{d}{dV_1} \right]_{PM} = \frac{2V_{\text{comp}} - 2V_1}{4RCFM_s} = 1.224 \times 10^{-2} \frac{\text{V}}{\Omega}$$

$$C_{i_{V_0}} = \left[ \frac{d}{dV_0} \right]_{PM} = \frac{(-2)V_{\text{comp}} + 2V_0}{4RCFM_s} = -1.245 \times 10^{-2} \frac{\text{V}}{\Omega}$$

[1] The resistance on the 432A Power meters is set to 200  $\Omega$  for this test

[2] The average Calibration Factor from the previous six sensors on the Production Line

$$Ci_R = \left[ \frac{d}{dR} \right]_{PM} = \frac{(-2)V_{comp}(V_1 - V_0) + V_0^2 - V_1^2}{4RCFM_S} = -4.727 \times 10^{-6} \frac{W}{\Omega}$$

$$Ci_{CF} = \left[ \frac{d}{dCF} \right]_{PM} = \frac{(-2)V_{comp}(V_1 - V_0) + V_0^2 - V_1^2}{4RCF^2 M_S} = -9.696 \times 10^{-4} W$$

$$Ci_{M_S} = \left[ \frac{d}{dM_S} \right]_{PM} = \frac{(-2)V_{comp}(V_1 - V_0) + V_0^2 - V_1^2}{4RCFM_M^2} = -9.454 \times 10^{-4(6)} W$$

## Combined Standard Uncertainty (uc(y))

**Table C-2** Combined Standard Uncertainty

Symbol	Source of Uncertainty	Value	Probability Distribution	Divisor	Ci	Ui/mW
U(V <sub>0</sub> )	Two Voltage measurements on a 3458A DMM	69.65 $\mu$ W	Rectangular	1.732	$2.129 \times 10^{-04}$ V/ $\Omega$	0.009
U(V <sub>1</sub> )	Two Voltage measurements on a 3458A DMM	69.45 $\mu$ W	Rectangular	1.732	$1.224 \times 10^{-02}$ V/ $\Omega$	0.491
U(V <sub>comp</sub> )	Voltage measurement on 3458A DMM	49.25 $\mu$ W	Rectangular	1.732	$-1.245 \times 10^{-02}$ V/ $\Omega$	0.354
U(R)	4 wire Resistance measurement on 3458A DMM	0.0046 $\Omega$	Rectangular	1.732	$-4.727 \times 10^{-06}$ W/ $\Omega$	0.013
U(CF)	Calibration factor for Thermistor	0.002	Normal	2	$-9.696 \times 10^{-04}$ W	0.970
U(M <sub>s</sub> )	Mismatch between the DUT and the Thermistor	0.0012	U shaped	$\sqrt{2}$	$-9.454 \times 10^{-04}$ W	0.802
U(Drift)	Drift of 8478B Thermistor	0.0006	Normal	2	$1.00 \times 10^{-03}$ W	0.3
U(Rep)	Repeatability of the complete measurement	0.057 $\mu$ W	Sigma	1	1	0.057
U(c)	Combined Uncertainty		Normal			1.429
U <sup>[a]</sup>	Expanded Uncertainty	k = 2	Normal			2.859

[a] Using Keysight's standard 95.5% confidence the coverage factor is k = 2.00

## Expanded Uncertainty

The expanded uncertainty is: **U= 3.030 mW**, as a percent of 1.000 mW: **U = 0.303%**



# D Measurement Uncertainty Analysis - Instrument Accuracy Test

Measurement Introduction [162](#)

## NOTE

The Measurement Uncertainty Analysis described in this Appendix uses different test equipment from that listed in this Service Guide. However, the equipment used, and the Measurement Uncertainty results, are similar enough to make the analysis useful. For example, the 11683A H01 Range Calibrator performs the same function as the modified 8482A used in this analysis. Similarly, the Datron/Fluke DC Calibrator performs the same function as the combined 3245/3458A setup.

---

## Measurement Introduction

In the Instrument Accuracy test the DUT measures power levels output from the test station from  $-25$  dBm to  $+20$  dBm.

A modified 8482A sensor is used to perform this measurement; it has had its thermocouple sensor (RF to DC converter) removed. This allows extremely accurate DC levels to be injected into the sensor from a 3245 Universal Source. The output from the universal source is measured at the head of the sensor by a 3458 DMM. In effect there is now zero measurement uncertainty associated with the Universal Source, as the 3458 DMM has assumed all the uncertainty.

In this test, DC signals are injected into the modified sensor. These are made in 5 dB steps, from  $-25$  dBm to  $+20$  dBm. A conversion from voltage to power is required to achieve this. The measurement setup is shown in [Figure D-1](#).

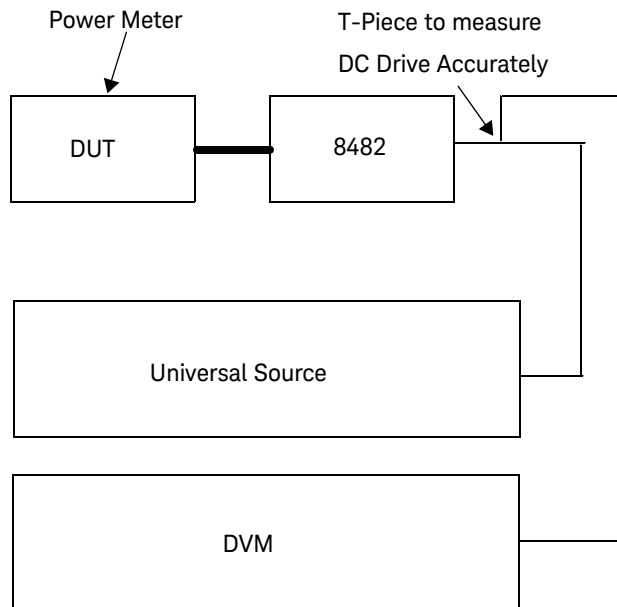

**Figure D-1** Measurement Setup

## Uncertainties

Universal Source:	No Uncertainties
DMM:	Yes (Type B)
8482:	No*
Extraneous signals, cables connectors and	Yes (Type A)

\* There is no uncertainty involved within the 8482A sensor, as a relative power is being measured. Before any measurement is made, an equivalent voltage to 0 dBm is applied to the 8482 sensor to allow the power meter calibration.

It is not important if the sensor creates an offset during this calibration procedure, provided this offset is present throughout all the different power levels. The 8482A sensor is linear from -25 dBm up to 0 dBm, and hence the same offset would always be present. Between 0 dBm and 20 dBm, look up tables are employed to counteract the non-linear behavior of the sensor at higher power levels.

**Example:** Consider a DC voltage from the Universal Source applied to the 8482A sensor, producing a power of 0.2 dBm instead of 0 dBm (for example, a 0.2 dBm offset). The measuring device (for example, the power meter) takes this 0.2 dBm value as being 0 dBm, and adjusts itself accordingly. Now throughout every measurement level, the 8482A and the power meter has the same 0.2 dBm offset (because the sensor is linear).

## Define the Measurand

The measurand is the Measurement Accuracy of the DUT.

## Define the Measurement Equation

Measurement Accuracy = ~~DUT Measure~~ - Test System Power

Where:

Test System Power = (Measure voltage × Volts/Power Conversion) + Test Station Error

### NOTE

Test Station Error (TSE) is the error contribution of the cables, connectors, noise, and so forth, that cannot be measured independently.

**NOTE**

The measurement uncertainty only relates to the test station, in this case, a power meter is the most accurate method of measuring power. Hence the reason the DUT Measure component can be ignored in the measurement equation. However, taking a number of measurements of the test system with the same power meter, averages out the error resolution or minimize it to the extent where the magnitude error is many times smaller than the station error.

Hence: Measurement Accuracy = f(MV , TSE)

The Measurement Uncertainty is not calculated from different sensor and power meter combinations, rather it is taken care of in the Customer Limit specification setting. Hence using the same power meter and making measurements a number of times will give us the uncertainty of the test station, without the uncertainty associated with the meter itself. By taking n samples of the same meter/DUT in effect we are averaging out the error associated with the DUT's measurement capability leaving us with a raw test station uncertainty which is made up from TSE and the DMM error, for example, the Measured Voltage (MV).

The method that is used to calculate the Measurement Uncertainty of our test station is a combination of Type A and Type B analysis in line with the ISO Expression of Measurement Uncertainty Guide.

**Uncertainty Equation**

$$u^2(MA) = [C_{TSE} \cdot u(TSE)]^2 + [C_{MV} \cdot u(MV)]^2$$

**TSE**

The Measurement Uncertainty of the Measurement Accuracy is calculated from testing the same DUT at 5dB step power level from -25 dBm to +20 dBm.

**Standard Uncertainty u(xi):**

Table D-1 shows the standard deviation of the 30 readings from the DUT at various power levels.

**Table D-1** Standard Uncertainty Results

Power Level	Standard Deviation of 30 Readings	Conversion to Linear Units Standard Uncertainty
$u(x(-25))$ 3.162 $\mu$ W	0.0132 dB	0.0097 $\mu$ W
$u(x(-20))$ 10 $\mu$ W	0.0038 dB	0.009 $\mu$ W
$u(x(-15))$ 31.62 $\mu$ W	0.0013 dB	0.0095 $\mu$ W
$u(X(-10))$ 100 $\mu$ W	0.0015 dB	0.035 $\mu$ W
$u(X(-5))$ 316.2 $\mu$ W	0.0004 dB	0.03 $\mu$ W
$u(X(0))$ 1 mW	0.0003 dB	0.00007 mW
$u(X(5))$ 3.16227 mW	0.0003 dB	0.00022 mW
$u(X(10))$ 10 mW	0.0003 dB	0.000690 mW
$u(X(15))$ 31.62277 mW	0.0003 dB	0.0022 mW
$u(X(20))$ 100 mW	0.0004 dB	0.0092 mW

The distributions are all normal.

**3458A DMM Uncertainty:**

The uncertainty of the voltage measured by the 3458A is:

$$\text{Error} = (\text{ppm of reading} + \text{ppm of range}) + (\text{factory traceability}) + (\text{temperature coefficient})$$

**Conditions:** 1 Year Calibration and temperature variance +/-5 °C with ACAL on dc volts.

**Reference:** 3458A Operating Manual Appendix A

**Factory Traceability:** From 6 ppm to 0.5 ppm Standard Uncertainty depending on range.

**Worst case error on 0.1 V range:**

$$\begin{aligned} \text{Error} &= ((9 \text{ ppm} \times 100 \text{ mV}) + (3 \text{ ppm} \times 100 \text{ mV})) + (6 \text{ ppm} \times 100 \text{ mV}) + 5((0.15 \text{ ppm} \\ &\times 100 \text{ mV}) + 100 \text{ mV}) \\ &= 2.375 \mu\text{V} \\ \text{Percentage Error} &= 0.002375\% \end{aligned}$$

Voltage Error	Distribution	Standard Uncertainty
2.375 $\mu\text{V}$	Rectangular	1.371 $\mu\text{V}$

**Worst case error on 1V range**

$$\begin{aligned} \text{Error} &= ((8 \text{ ppm} \times 1.0 \text{ V}) + (0.3 \text{ ppm} \times 1.0 \text{ V})) + (1 \text{ ppm} \times 1.0 \text{ V}) + 5((0.15 \text{ ppm} \times 1.0 \\ &\text{V}) + (0.1 \text{ ppm} \times 1.0 \text{ V})) \\ &= 10.55 \mu\text{V} \\ \text{Percentage Error} &= 0.001055\% \end{aligned}$$

Voltage Error	Distribution	Standard Uncertainty
10.55 $\mu\text{V}$	Rectangular	6.09 $\mu\text{V}$

**Worst case error on 10 V range**

$$\begin{aligned} \text{Error} &= ((8 \text{ ppm} \times 10.0 \text{ V}) + (0.05 \text{ ppm} \times 10.0 \text{ V})) + (1 \text{ ppm} \times 10.0\text{V}) + 5((0.15 \text{ ppm} \\ &\times 10.0 \text{ V}) + (0.01 \text{ ppm} \times 10.0 \text{ V})) \\ &= 98.5 \mu\text{V} \\ \text{Percentage Error} &= 0.000985\% \end{aligned}$$

Voltage Error	Distribution	Standard Uncertainty
98.5 $\mu\text{V}$	Rectangular	56.8 $\mu\text{V}$

**Worst case error on 15.8 V maximum power setting**

$$\begin{aligned} \text{Error} &= ((10 \text{ ppm} \times 15.8 \text{ V}) + (0.3 \text{ ppm} \times 100.0 \text{ V})) + (0.5 \text{ ppm} \times 15.8 \text{ V}) + 5((0.15 \\ &\text{ppm} \times 15.8 \text{ V}) + (0.1 \text{ ppm} \times 100 \text{ V})) \\ &= 257.75 \mu\text{V} \\ \text{Percentage Error} &= 0.00163\% \end{aligned}$$

Voltage Error	Distribution	Standard Uncertainty
257.75 $\mu\text{V}$	Rectangular	148.8 $\mu\text{V}$

## D Measurement Uncertainty Analysis - Instrument Accuracy Test

The relationship between the applied voltage from the Universal Source to the corresponding power is given from:

$$1 \text{ mW} = 0.14493 \text{ mV}$$

This is a linear relationship, for example, 0.1 mW is equal to 0.014493 volts. This relationship is valid between 0 dBm and -30 dBm.

However, above 0 dBm a look up table is used for voltage to mW conversion. This is due to the sensors non linear behavior at higher power levels. The voltage correction at the appropriate points is shown in [Table D-2](#).

**Table D-2** Voltage Correction Multiplier

Power (mW)	Voltage Correction Multiplier
1	1
10	1.006577
100	1.075533



Therefore to attain a power of 100 mW as shown in the [Table D-2](#), instead of applying 14.4493 Volts, the actual amount of voltage required from the Universal Source would be:

$$14.4493 \times 1.075533 = 15.6 \text{ Volts}$$

By using the DMM Uncertainties calculated previously the worst case voltage and corresponding power errors can be calculated.

Power Setting (mW)	Applied Volts	DMM Error on Range Standard Uncertainty ( $\mu\text{V}$ )	Worst Case Voltage Error on Range (%)	Worst Case Power Error on Range ( $\mu\text{W}$ )
0.001	0.14493 mV	<1.371 $\mu\text{V}$	0.946%	0.00946 $\mu\text{W}$
0.01	1.4493 mV	<1.371 $\mu\text{V}$	0.0946%	0.00946 $\mu\text{W}$
0.1	14.493 mV	1.371 $\mu\text{V}$	0.00946%	0.00946 $\mu\text{W}$
1	144.93 mV	6.09 $\mu\text{V}$	0.00420%	0.042 $\mu\text{W}$
10	1.4588 V	56.8 $\mu\text{V}$	0.00389%	0.389 $\mu\text{W}$
100	15.6 V	148.8 $\mu\text{V}$	0.00095%	0.95 $\mu\text{W}$

## Sensitivity Coefficients $C_i$ :

The partial derivatives of the measurement equation

**$Y = f(MV, TSE)$**  equal 1.

TSE is derived from a number of readings taken by the test station to characterize the cabling, connectors noise and so forth. Therefore no measurement equation exists to differentiate. It is a measured value of magnitude.

Hence:

$$C_{TSE} = \frac{d}{dTSE} TSE = 1$$

The DMM Measured Voltage also has a sensitivity coefficient equal to 1. As with the TSE the Measured Voltage is not computed from an equation. Is it a real value that the DMM actually measures.

Hence:

$$C_{MV} = \frac{d}{dMV} MV = 1$$

## Combined Standard Uncertainty $uc(y)$ :

There is no correlation associated with this measurement

Hence:

$$uc^2(y) = \sum [C_{TSE} \cdot u(TSE)]^2, [C_{MV} \cdot u(MV)]^2$$

**Table D-3** shows the combined standard uncertainty at all the power levels from 3  $\mu$ W (-25 dBm) to 100 mW (20 dBm).

**Table D-3** Combined Standard Uncertainty

Power	U(TSE)	U(MV) (Converted)	uc(y)	k uc(y) k = 2
3.16 $\mu$ W	0.0097 $\mu$ W	0.00946 $\mu$ W	0.0135 $\mu$ W	0.0271 $\mu$ W
10 $\mu$ W	0.009 $\mu$ W	0.00946 $\mu$ W	0.0131 $\mu$ W	0.0262 $\mu$ W
31.6 $\mu$ W	0.0095 $\mu$ W	0.00946 $\mu$ W	0.0134 $\mu$ W	0.0268 $\mu$ W
100 $\mu$ W	0.035 $\mu$ W	0.00946 $\mu$ W	0.0363 $\mu$ W	0.0725 $\mu$ W
316 $\mu$ W	0.03 $\mu$ W	0.042 $\mu$ W	0.0516 $\mu$ W	0.1032 $\mu$ W
1 mW	0.00007 mW	0.000042 mW	0.000082 mW	0.00016 mW
3.16 mW	0.00022 mW	0.000389 mW	0.000447 mW	0.00089 mW
10 mW	0.00069 mW	0.000389 mW	0.000792 mW	0.00158 mW
31.6 mW	0.0022 mW	0.00095 mW	0.00239 mW	0.00479 mW
100 mW	0.0092 mW	0.00095 mW	0.00924 mW	0.01850 mW

### Expanded Uncertainty $kuc(y)$ :

The Expanded Uncertainty for each power level is given in the table above, using Keysight Technologies's standard 95% confidence level gives a coverage factor of 2.

$$K = 2$$



This information is subject to change without notice. Always refer to the Keysight website for the latest revision.

© Keysight Technologies 2001–2021  
Edition 15, December 13, 2021

Printed in Malaysia



E4416-90014

[www.keysight.com](http://www.keysight.com)