

Keysight E36200 Series Autoranging DC Power Supplies

Notices

Copyright Notice

© Keysight Technologies 2019, 2021
No part of this manual may be reproduced in any form or by any means (including electronic storage and retrieval or translation into a foreign language) without prior agreement and written consent from Keysight Technologies as governed by United States and international copyright laws.

Manual Part Number

E36200-90009

Edition

Edition 2, May 21, 2021

Printed in:

Printed in Malaysia

Published by:

Keysight Technologies
Bayan Lepas Free Industrial Zone,
11900 Penang, Malaysia

Technology Licenses

The hardware and/or software described in this document are furnished under a license and may be used or copied only in accordance with the terms of such license.

Declaration of Conformity

Declarations of Conformity for this product and for other Keysight products may be downloaded from the Web. Go to <http://www.keysight.com/go/conformity>. You can then search by product number to find the latest Declaration of Conformity.

U.S. Government Rights

The Software is “commercial computer software,” as defined by Federal Acquisition Regulation (“FAR”) 2.101. Pursuant to FAR 12.212 and 27.405-3 and Department of Defense FAR Supplement (“DFARS”) 227.7202, the U.S. government acquires commercial computer software under the same terms by which the software is customarily provided to the public. Accordingly, Keysight provides the Software to U.S. government customers under its standard commercial license, which is embodied in its End User License Agreement (EULA), a copy of which can be found at <http://www.keysight.com/find/sweula>. The license set forth in the EULA represents the exclusive authority by which the U.S. government may use, modify, distribute, or disclose the Software. The EULA and the license set forth therein, does not require or permit, among other things, that Keysight: (1) Furnish technical information related to commercial computer software or commercial computer software documentation that is not customarily provided to the public; or (2) Relinquish to, or otherwise provide, the government rights in excess of these rights customarily provided to the public to use, modify, reproduce, release, perform, display, or disclose commercial computer software or commercial computer software documentation. No additional government requirements beyond those set forth in the EULA shall apply, except to the extent that those terms, rights, or licenses are explicitly required from all providers of commercial computer software pursuant to the FAR and the DFARS and are set forth specifically in writing elsewhere in the EULA. Keysight shall be under no obligation to update, revise or otherwise modify the Software. With respect to any technical data as defined by FAR 2.101, pursuant to FAR 12.211 and 27.404.2 and DFARS 227.7102, the U.S. government acquires no greater than Limited Rights as defined in FAR 27.401 or DFAR 227.7103-5 (c), as applicable in any technical data.

Warranty

THE MATERIAL CONTAINED IN THIS DOCUMENT IS PROVIDED “AS IS,” AND IS SUBJECT TO BEING CHANGED, WITHOUT NOTICE, IN FUTURE EDITIONS. FURTHER, TO THE MAXIMUM EXTENT PERMITTED BY APPLICABLE LAW, KEYSIGHT DISCLAIMS ALL WARRANTIES, EITHER EXPRESS OR IMPLIED, WITH REGARD TO THIS MANUAL AND ANY INFORMATION CONTAINED HEREIN, INCLUDING BUT NOT LIMITED TO THE IMPLIED WARRANTIES OF MERCHANTABILITY AND FITNESS FOR A PARTICULAR PURPOSE. KEYSIGHT SHALL NOT BE LIABLE FOR ERRORS OR FOR INCIDENTAL OR CONSEQUENTIAL DAMAGES IN CONNECTION WITH THE FURNISHING, USE, OR PERFORMANCE OF THIS DOCUMENT OR OF ANY INFORMATION CONTAINED HEREIN. SHOULD KEYSIGHT AND THE USER HAVE A SEPARATE WRITTEN AGREEMENT WITH WARRANTY TERMS COVERING THE MATERIAL IN THIS DOCUMENT THAT CONFLICT WITH THESE TERMS, THE WARRANTY TERMS IN THE SEPARATE AGREEMENT SHALL CONTROL.

Safety Information

CAUTION











A CAUTION notice denotes a hazard. It calls attention to an operating procedure, practice, or the like that, if not correctly performed or adhered to, could result in damage to the product or loss of important data. Do not proceed beyond a CAUTION notice until the indicated conditions are fully understood and met.

WARNING

A WARNING notice denotes a hazard. It calls attention to an operating procedure, practice, or the like that, if not correctly performed or adhered to, could result in personal injury or death. Do not proceed beyond a WARNING notice until the indicated conditions are fully understood and met.

Safety Symbols

The following symbols on the instrument and in the documentation indicate precautions which must be taken to maintain safe operation of the instrument.

	Caution, risk of danger (refer to accompanying text for the specific Warning or Caution information)
	Caution, risk of electric shock
	Protective earth (ground) terminal
	Earth (ground) terminal
	Frame or chassis (ground) terminal
	Standby supply, the instrument is not completely disconnected from AC mains when the switch is off
	Direct current (DC)
	Alternating current (AC)
	Plus, positive polarity
	Minus, negative polarity

Safety Considerations

Read the information below before using this instrument.

The following general safety precautions must be observed during all phases of operation, service, and repair of this instrument. Failure to comply with these precautions or with specific warnings elsewhere in this manual violates safety standards for design, manufacture, and intended use of the instrument. Keysight Technologies assumes no liability for the customer's failure to comply with these requirements.

WARNING

– BEFORE APPLYING POWER

Verify that the correct fuse is installed. See “Fuse Information” in the *E36200 Series User's Guide* for additional details. Ensure the mains supply voltage fluctuation do not exceed $\pm 10\%$ of the nominal supply voltage.

– GROUND THE INSTRUMENT

This product is a Safety Class I instrument (provided with a protective earth terminal). To minimize shock hazard, the instrument chassis and cabinet must be connected to an electrical ground. The instrument must be connected to the AC power supply mains through a three-conductor power cable, with the third wire firmly connected to an electrical ground (safety ground) at the power outlet. Any interruption of the protective (grounding) conductor or disconnection of the protective earth terminal will cause a potential shock hazard that could result in personal injury. If the instrument is to be energized via an external autotransformer for voltage reduction, be certain that the autotransformer common terminal is connected to the neutral (earthed pole) of the AC power lines (supply mains).

– DO NOT OPERATE IN AN EXPLOSIVE ATMOSPHERE OR WET ENVIRONMENTS

Do not operate the device around flammable gases or fumes, vapor, or wet environments.

WARNING**- DO NOT OPERATE DAMAGED OR DEFECTIVE INSTRUMENTS**

Instruments that appear damaged or defective should be made inoperative and secured against unintended operation until they can be repaired by qualified service personnel.

- DO NOT SUBSTITUTE PARTS OR MODIFY INSTRUMENT

Because of the danger of introducing additional hazards, do not install substitute parts or perform any unauthorized modification to the instrument. Return the instrument to a Keysight Technologies Sales and Service Office for service and repair to ensure that safety features are maintained. To contact Keysight for sales and technical support, refer to the support links on the following Keysight website: www.keysight.com/find/assist (worldwide contact information for repair and service).

- USE THE POWER CORD PROVIDED

Use the device with the power cord provided with the shipment.

- USE THE DEVICE AS SPECIFIED

If the device is used in a manner not specified by manufacturer, the device protection may be impaired.

- DO NOT BLOCK VENTILATION HOLES

Do not block any of the ventilation holes of the device.

- OBSERVE ALL DEVICE MARKINGS BEFORE CONNECTING TO DEVICE

Observe all markings on the device before connecting any wiring to the device.

- TURN DEVICE OFF BEFORE CONNECTING TO OUTPUT TERMINALS

Turn off the device power before connecting to the output terminals.

- ENSURE COVER IS SECURED IN PLACE

Do not operate the device with the cover removed or loosened.

WARNING**- TURN DEVICE OFF AND REMOVE ALL CONNECTIONS BEFORE INSTALLING THE GPIB INTERFACE**

Turn off the power and remove all connections, including the power cord, from the instrument prior installation of the GPIB interface.

- ENSURE PROPER AWG CABLE IS USED

Use a cable with the correct voltage and AWG rating based on the intended setup when operating the E36200A Series autoranging DC power supplies.

- DO NOT TOUCH CABLES DURING OPERATION

Do not touch the cable while the instrument output is operational to prevent electric shock hazard and burn hazard.

CAUTION**CLEAN WITH SLIGHTLY DAMPENED CLOTH**

Clean the outside of the instrument with a soft, lint-free, slightly dampened cloth. Do not use detergent, volatile liquids, or chemical solvents.

NOTE**CONNECT USB CABLE WITH FERRITE CORE**

Connect a USB cable with a ferrite core to the rear panel USB port of the instrument for better performance.

Environmental Conditions

The E36200 Series is designed for indoor use and in an area with low condensation. The table below shows the general environmental requirements for this instrument.







Environmental condition	Requirement
Temperature	Operating condition – 0 °C to 40 °C
	Storage condition – –20 °C to 70 °C
Humidity	Operating condition – Up to 80% RH at 40 °C (non-condensing)
	Storage condition – Up to 90% RH at 65 °C (non-condensing)
Altitude	Up to 2000 m
Pollution degree	2

Regulatory Information

The E36200 Series complies with the following safety and Electromagnetic Compatibility (EMC) compliances:

- Low Voltage Directive 2014/35/EU
- EMC Directive 2014/30/EU

Regulatory Markings

	<p>The RCM mark is a registered trademark of the Australian Communications and Media Authority.</p>
	<p>The CE mark is a registered trademark of the European Community. This CE mark shows that the product complies with all the relevant European Legal Directives.</p> <p>ICES/NMB-001 indicates that this ISM device complies with the Canadian ICES-001. Cet appareil ISM est conforme a la norme NMB-001 du Canada. ISM GRP.1 Class A indicates that this is an Industrial Scientific and Medical Group 1 Class A product.</p>
	<p>This symbol is a South Korean Class A EMC Declaration. This is a Class A instrument suitable for professional use and in electromagnetic environment outside of the home.</p>
	<p>The CSA mark is a registered trademark of the Canadian Standards Association.</p>
	<p>This symbol indicates the time period during which no hazardous or toxic substance elements are expected to leak or deteriorate during normal use. Forty years is the expected useful life of the product.</p>
	<p>This instrument complies with the WEEE Directive marking requirement. This affixed product label indicates that you must not discard this electrical or electronic product in domestic household waste.</p>

Waste Electrical and Electronic Equipment (WEEE) Directive

This instrument complies with the WEEE Directive marking requirement. This affixed product label indicates that you must not discard this electrical or electronic product in domestic household waste.

Product category:

With reference to the equipment types in the WEEE directive Annex 1, this instrument is classified as a “Monitoring and Control Instrument” product.

The affixed product label is as shown below.



Do not dispose in domestic household waste.

To return this unwanted instrument, contact your nearest Keysight Service Center, or visit <http://about.keysight.com/en/companyinfo/environment/takeback.shtml> for more information.

Sales and Technical Support

To contact Keysight for sales and technical support, refer to the support links on the following Keysight websites:

- www.keysight.com/find/e36200
(product-specific information and support, software and documentation updates)
- www.keysight.com/find/assist
(worldwide contact information for repair and service)

THIS PAGE HAS BEEN INTENTIONALLY LEFT BLANK.

Table of Contents

Safety Symbols	3
Safety Considerations	4
Environmental Conditions	7
Regulatory Information	7
Regulatory Markings	8
Waste Electrical and Electronic Equipment (WEEE) Directive	9
Product category:	9
Sales and Technical Support	9
1 Service and Maintenance	
Specifications and Characteristics	14
General Information	14
Types of service available	14
Obtaining repair service (worldwide)	14
Repackaging for shipment	14
Cleaning and handling	15
Troubleshooting	16
Self-Test Procedures	16
Replacing the Fuse	16
User Replaceable Parts	17
Battery Replacement	17
Replacing the battery	18
Disassembly	20
Tools required	20
Removing/Installing the optional GPIB interface	20
Replacing the front panel binding post	21
2 Verification and Adjustments	
Performance Verification	54
Recommended test equipment	54

Test considerations	55
Measurement techniques	56
Constant Voltage (CV) verification	58
CV load and line regulation	59
Low range current verification	67
Constant Current (CC) verification	69
Test Record Forms	74
Calibration Adjustment Procedures	82
Closed-case electronic calibration	82
Calibration interval	82
Calibration adjustment process	82
Calibration security	83
Calibration count	84
Calibration message	85
Saving calibration data	85
Calibration auto save	85
Calibration procedure	86
Save the calibration data	88

1 Service and Maintenance

Specifications and Characteristics	14
General Information	14
Troubleshooting	16
Self-Test Procedures	16
Replacing the Fuse	16
User Replaceable Parts	17
Battery Replacement	17
Disassembly	20

This chapter provides the specifications and service information on cleaning, troubleshooting, repair, and replaceable parts of the E36200 Series autoranging DC power supplies. This chapter also explains how to assemble and disassemble the E36200 Series autoranging DC power supplies.

Specifications and Characteristics

NOTE

For the specifications and characteristics of the E36200 Series autoranging DC power supplies, refer to its datasheet at <http://literature.cdn.keysight.com/litweb/pdf/5992-3747EN.pdf>.

General Information

Types of service available

If your instrument fails during the warranty period, Keysight Technologies will repair or replace it under the terms of your warranty. After your warranty expires, Keysight offers repair services at competitive prices. You also have the option to purchase a service contract that extends the coverage after the standard warranty expires.

Obtaining repair service (worldwide)

To obtain service for your instrument, contact your nearest Keysight Technologies Service Center. They will arrange to have your unit repaired or replaced, and can provide warranty or repair-cost information where applicable. Ask the Keysight Technologies Service Center for shipping instructions, including what components to ship. Keysight recommends that you retain the original shipping carton for return shipments.

Repackaging for shipment

Ensure the following to ship the unit to Keysight for service or repair:

- Attach a tag to the unit identifying the owner and indicating the required service or repair. Include the model number and full serial number.
- Place the unit in its original container with appropriate packaging material.
- Secure the container with strong tape or metal bands.

- If the original shipping container is unavailable, use a container that will ensure at least 10 cm (4 in.) of compressible packaging material around the entire instrument. Use static-free packaging materials.

Keysight suggests that you always insure your shipments.

Cleaning and handling

Cleaning

To prevent electrical shock, disconnect the instrument from AC mains power and disconnect all test leads before cleaning. Clean the outside of the instrument using a soft, lint-free, cloth slightly dampened with water.

- Do not use detergent or solvents.
- Do not attempt to clean internally.

If required, contact a Keysight Technologies Sales and Service office to arrange for proper cleaning to ensure that safety features and performance are maintained.

Electrostatic Discharge (ESD) precautions

Almost all electrical components can be damaged by electrostatic discharge (ESD) during handling. Component damage can occur at electrostatic discharge voltages as low as 50 V.

The following guidelines will help prevent ESD damage during service operations:

- Disassemble instruments only in a static-free work area.
- Use a conductive work area to reduce static charges.
- Use a conductive wrist strap to reduce static charge accumulation.
- Minimize handling.
- Keep replacement parts in original static-free packaging.
- Remove all plastic, foam, vinyl, paper, and other static-generating materials from the immediate work area.

Troubleshooting

Before troubleshooting or repairing the instrument, make sure the failure is in the instrument rather than any external connections. Also make sure that the instrument was accurately calibrated within the last year (see “[Calibration Adjustment Procedures](#)” on page 82 and “[Calibration interval](#)” on page 82 for details).

Perform the following verifications if the unit is inoperative:

- Verify that the ac power cord is connected to the power supply.
- Verify that the front-panel power switch is depressed.

Self-Test Procedures

A power-on self-test occurs automatically when you turn on the power supply. This limited test assures you that the power supply is operational.

Refer to the *E36200 Series User's Guide* for more information on how to run a complete self-test of the power supply (**Chapter 2, “General Operating Information” > Utilities Menu - Test/Setup > Self-Test**).

Replacing the Fuse

The fuse is located within the power supply's fuse-holder assembly on the rear panel. Refer to the *E36200 Series User's Guide* for more information on how to replace a faulty or blown fuse (**Chapter 1, “Product Information” > Fuse Information**).

User Replaceable Parts

You can find the instrument support part list from the *Keysight's Test & Measurement Parts Catalog* at <http://www.keysight.com/find/parts>.

Battery Replacement

WARNING**SHOCK HAZARD**

Only qualified, service-trained personnel who are aware of the hazards involved should remove instrument covers. Always disconnect the power cable and any external circuits before removing the instrument cover. Some circuits are active and have power for a short time even when the power switch is turned off.

The internal battery powers the real-time clock. The primary function of the clock is to provide a time stamp for the internal file system. If the battery fails, the clock and time stamp function will not be available. No other instrument functions are affected.

Under normal use at room temperature, the lithium battery has a life expectancy between seven and ten years. Note that battery life will be reduced if the instrument is stored for a prolonged period at temperatures above 40 degrees Celsius.

The battery type is CR 2032 (3V).

Replacing the battery

NOTE

You will need a flat-bladed screwdriver to perform this procedure.

- 1 Remove the instrument top cover.
- 2 The battery is located at the front PC board.
- 3 Use a flat-bladed screwdriver and carefully pry up on the side of the battery.
- 4 Install the new battery.

Make sure that the positive side (+) is facing up. Place the battery under the small spring clips closest to the ribbon cable connector, then push down on the opposite end of the battery to seat the battery (see red arrow below). The top of the small spring clips should be visible after the battery is seated (see red circle below).

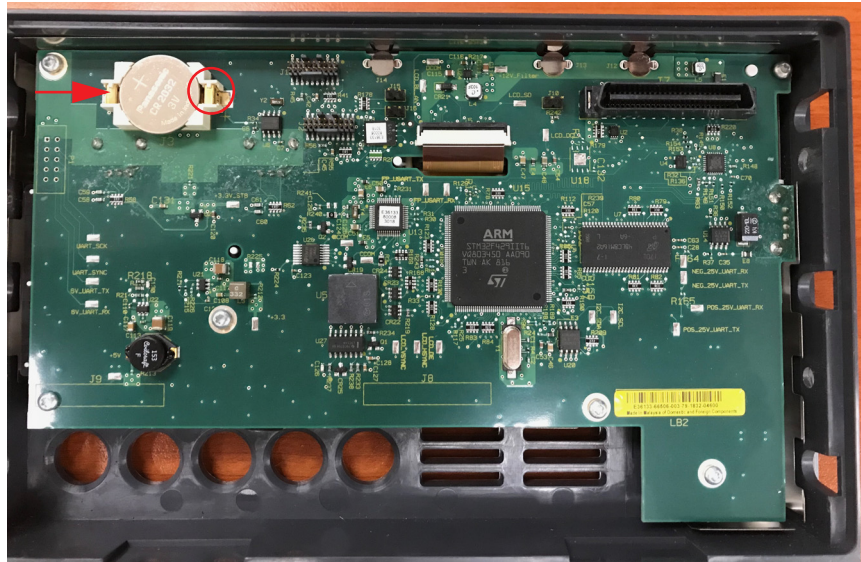

- 5 Replace the top cover when finished.

6 Reset the date and time.

Refer to the *E36200 Series User's Guide* for more information on how to reset the date and time. (**Chapter 2, "General Operating Information" > Utilities Menu - Test/Setup > User Settings > Date/Time**)

NOTE

Properly dispose of the old battery in accordance with local laws and regulations.

Disassembly

Tools required

Items	Torque value
PZ1 driver	9.0 in.lbs
T10 Torx driver	9.0 in.lbs
T8 Torx driver	9.0 in.lbs
1/4" nut socket	9.0 in.lbs
1/2" nut socket	3.5 in.lbs

Removing/Installing the optional GPIB interface

WARNING**TURN OFF POWER AND REMOVE ALL CONNECTIONS BEFORE PROCEED**

Turn off the power and remove all connections, including the power cord, from the instrument prior installation/removal of the GPIB interface.

WARNING**RETAIN GPIB COVER PLATE**

After installing the GPIB interface, retain the cover plate for use in the event that you ever remove the GPIB interface. The instrument should never be connected to power or inputs on the output terminals without either the GPIB interface or the cover plate securely covering the rear-panel opening.

Refer to the *E36200 Series User's Guide* for more information on how to remove or install the optional GPIB interface (**Chapter 1, "Product Information" > Installation > Installing the optional GPIB interface**).

Replacing the front panel binding post

WARNING

Only qualified, service-trained personnel should remove and replace the front panel binding post.

NOTE

The GPIB interface must be removed before you proceed to remove and replace the front panel binding post.

Disassembly procedures are model-specific. Refer to the procedures listed below for your respective E36200 Series model.

- “For E36231A and E36232A models only” on page 22
- “For E36233A models only” on page 32
- “For E36234A models only” on page 42

1 Service and Maintenance

For E36231A and E36232A models only

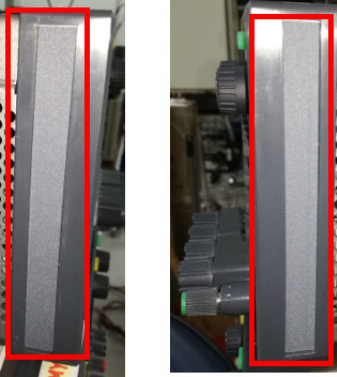
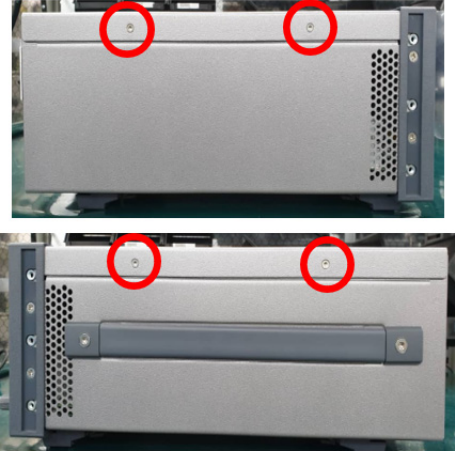
Step	Instructions	Visuals
1	Remove the side trims from the front panel.	 Two side views of the front panel of the device. In both images, a vertical grey trim piece on the left side is highlighted with a red rectangular border. The left image shows the trim against a dark background, while the right image shows it in the context of the device's front panel.
2	Remove four screws from the front panel using a T10 driver (two screws on each side).	 Two top-down views of the front panel. The top image shows the upper portion of the panel with two screws on each side circled in red. The bottom image shows the lower portion of the panel, also with two screws on each side circled in red. The screws are located on the top edge of the front panel.

Step	Instructions	Visuals
3	Remove the top panel. Slide the top panel towards the rear and lift it up.	
4	Remove the IO board thermal pad.	
5	Remove four Pozi screws from the front panel using a PZ1 driver (two screws on each side).	

1 Service and Maintenance

Step	Instructions	Visuals
------	--------------	---------

6 Gently pull out the front frame from the chassis.

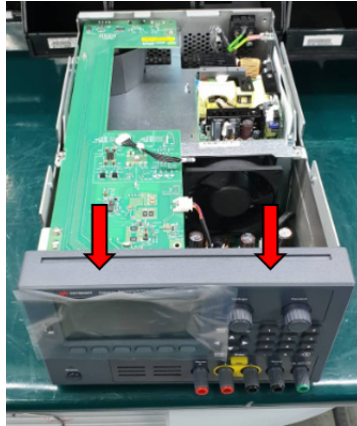

7 Detach the mainboard connector from the IO board.

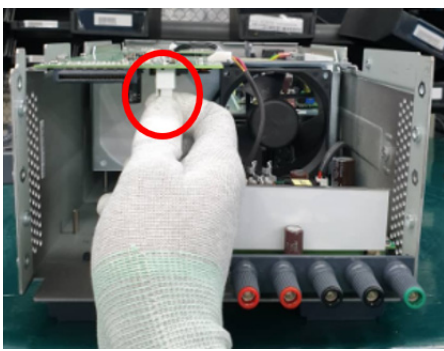
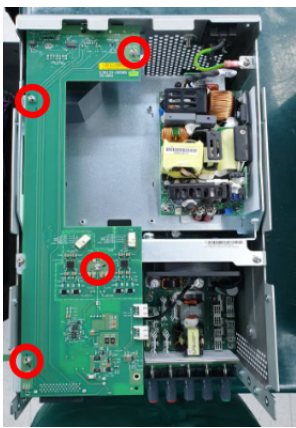

Step	Instructions	Visuals
8	Detach the power PSU connector from the IO board.	
9	Remove four screws from the IO board using a T10 driver. Remove the IO board from the chassis.	

1 Service and Maintenance

Step	Instructions	Visuals
------	--------------	---------

NOTE: Perform [step 10](#) and [step 12](#) only if you have installed the optional GPIB interface (see [“Removing/Installing the optional GPIB interface”](#) on page 20 for more details).

- 10** Remove one screw from the GPIB module plate using a T10 driver.

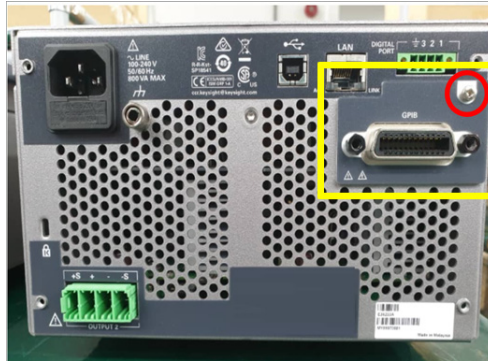



- 11** Detach the GPIB module connector from the IO board.

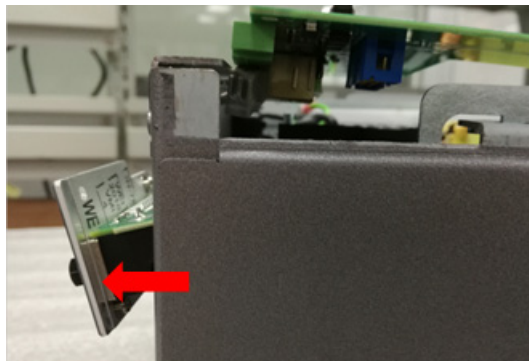

- 12** Remove the GPIB module from the chassis.

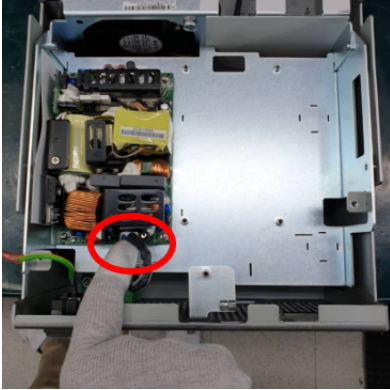
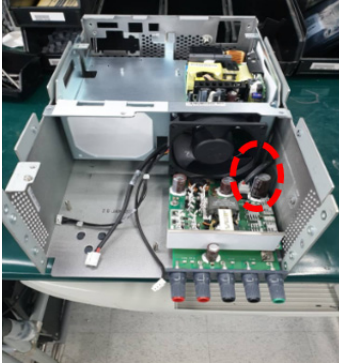

Step	Instructions	Visuals
13	Detach the AC inlet connector from the PSU module.	 A photograph showing the internal components of a power supply unit (PSU) module. A red circle highlights the AC inlet connector on the left side of the module. A person's hand is visible at the bottom, reaching towards the connector.
14	Detach the power PSU connector from the mainboard.	 A photograph showing the internal components of a mainboard. A red circle highlights the power PSU connector on the mainboard. The PSU module is visible in the background.
15	Remove one screw from the rear chassis using a T10 bit.	 A photograph showing the rear view of the chassis. A red circle highlights a screw on the rear panel. The chassis is dark grey and has a perforated metal mesh on the front.

1 Service and Maintenance

Step	Instructions	Visuals
------	--------------	---------

16 Remove two screws from the bracket using a T10 bit. Remove the bracket from the chassis.



17 Remove seven screws from the PCA mainboard using a T10 bit.

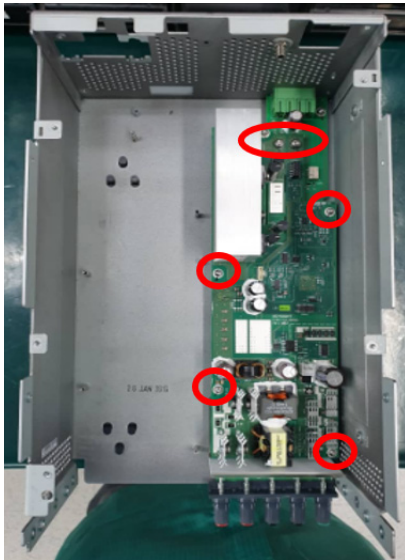

Step	Instructions	Visuals
------	--------------	---------

18 Lift and remove the PCA mainboard from the chassis.

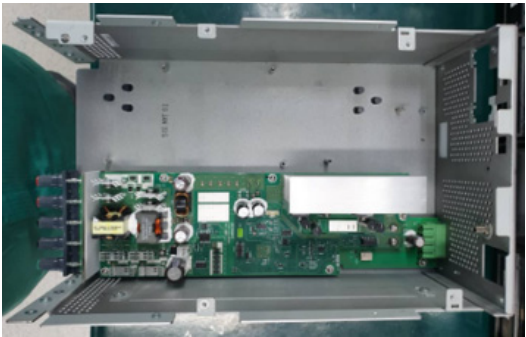

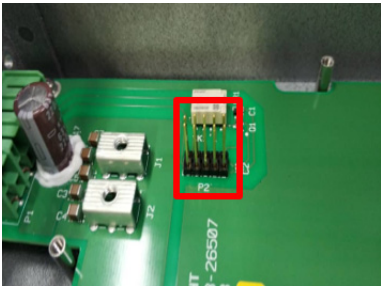

Take caution not to bend any of the connector pins on the IO board.

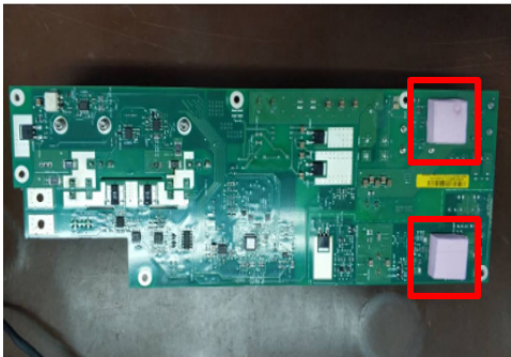

Ensure that the two thermal pad are present on the PCA mainboard before proceeding with the next step.



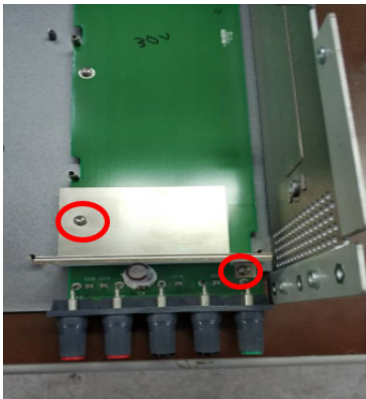

1 Service and Maintenance

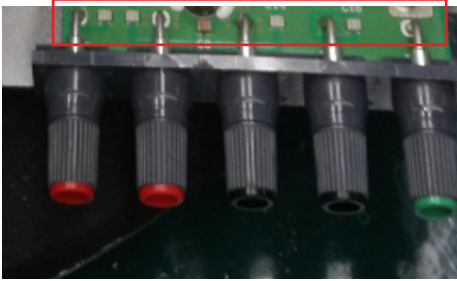
Step	Instructions	Visuals
19	Remove two screws from the IO board using a T10 bit.	 A close-up photograph of a green printed circuit board (IO board) mounted on a metal chassis. Two screws are circled in red: one is located on the left side of the board, and the other is on the right side, near the bottom edge. The board has several blue connectors at the bottom.
20	Remove three screws from the IO board using a T10 bit. Remove the IO board from the chassis.	 A photograph showing the IO board installed inside a metal chassis. Three screws are circled in red: two are on the top edge of the board, and one is on the left side. The chassis is open, and the board is clearly visible against the metal background.

Step	Instructions	Visuals
21	Unsolder the binding post assembly from the IO board. Replace the existing binding post assembly with a new binding post assembly.	
22	Perform the steps above in reverse order to reassemble back the instrument.	

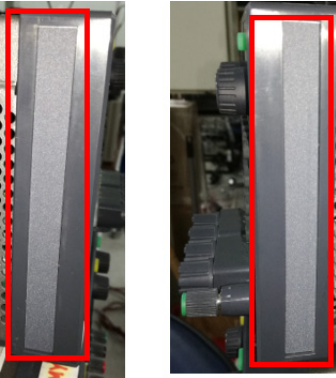
For E36233A models only

Step	Instructions	Visuals
1	Remove the side trims from the front panel.	
2	Remove four screws from the front panel using a T10 driver (two screws on each side).	
3	Remove the top panel. Slide the top panel towards the rear and lift it up.	

Step	Instructions	Visuals
------	--------------	---------

4 Remove the IO board thermal pad.

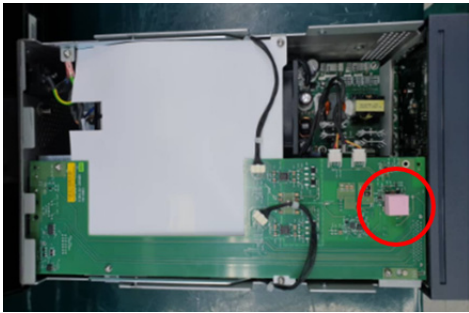

5 Remove four Pozi screws from the front panel using a PZ1 driver (two screws on each side).



6 Detach the mainboard connectors from the IO board.

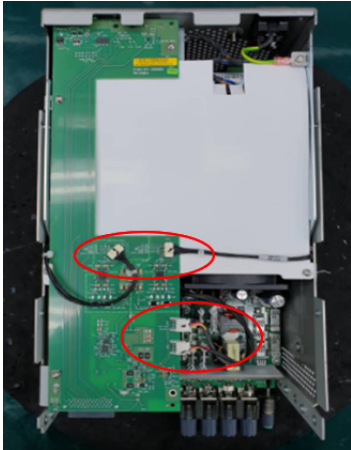

1 Service and Maintenance

Step	Instructions	Visuals
------	--------------	---------

7 Gently pull out the front frame from the chassis.



8 Detach the power PSU connector from the IO board.

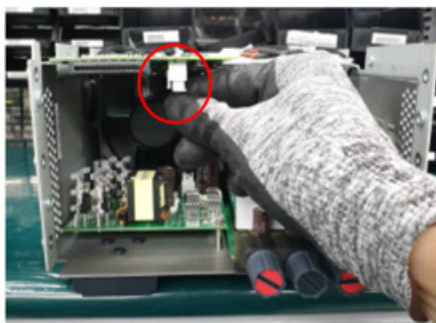

Step	Instructions	Visuals
------	--------------	---------

9 Remove four screws from the IO board using a T10 driver. Remove the IO board from the chassis.



NOTE: Perform step 10 and step 12 only if you have installed the optional GPIB interface (see "Removing/Installing the optional GPIB interface" on page 20 for more details).

10 Remove one screw from the GPIB module plate using a T10 driver.

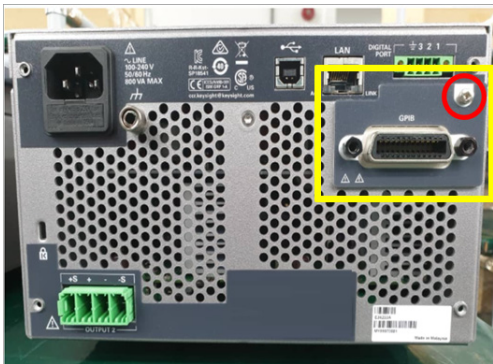

1 Service and Maintenance

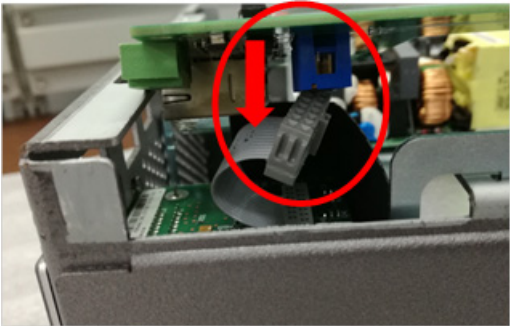
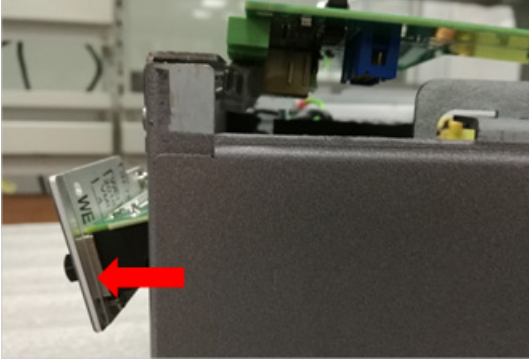
Step	Instructions	Visuals
11	Detach the GPIB module connector from the IO board.	 A close-up photograph of the internal components of a chassis. A GPIB module connector is being detached from the IO board. A red circle highlights the connector, and a red arrow points downwards, indicating the direction of removal.
12	Remove the GPIB module from the chassis.	 A close-up photograph of the GPIB module being removed from the chassis. A red arrow points to the left, indicating the direction of removal.

Step	Instructions	Visuals
------	--------------	---------

13 Remove two screws from the insulator using a T10 bit. Remove the insulator.

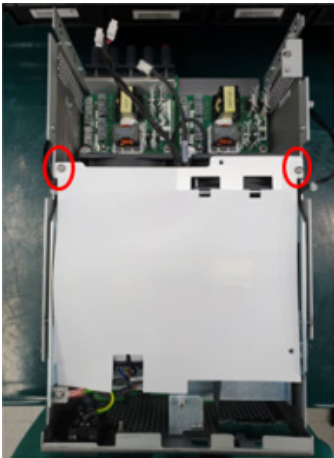

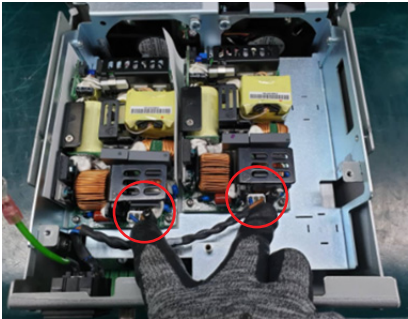

14 Detach the AC inlet connector from the PSU module.

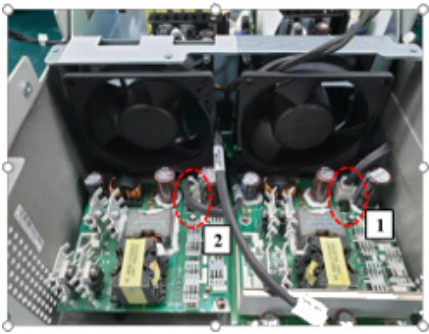

15 Detach the power PSU connectors from the mainboard.

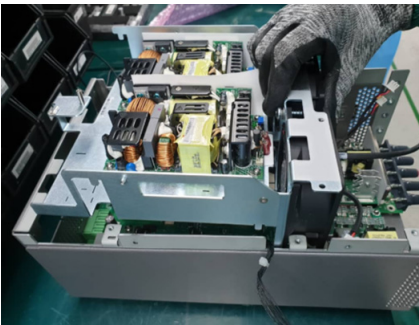

1 Service and Maintenance

Step	Instructions	Visuals
16	Remove one screw from the rear chassis using a T10 bit.	 A photograph of the rear chassis of a device. A single screw on the right side of the chassis is circled in red, indicating it is the one to be removed.
17	Remove two screws from the bracket using a T10 bit. Remove the bracket from the chassis.	  Two photographs illustrating the removal of a bracket. The top photo shows a close-up of a bracket with two screws circled in red. The bottom photo shows a hand using a T10 bit to remove one of these screws from the bracket, which is being lifted away from the chassis.

Step	Instructions	Visuals
------	--------------	---------

18 Remove 14 screws from the PCA mainboard using a T10 bit.

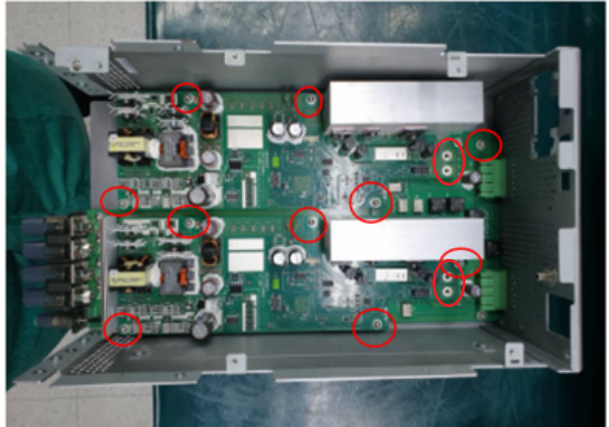

19 Lift and remove the the two PCA mainboards from the chassis.

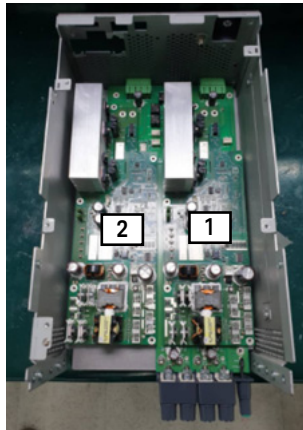

1 Service and Maintenance

Step	Instructions	Visuals
------	--------------	---------

Take caution not to bend any of the connector pins on the IO board.

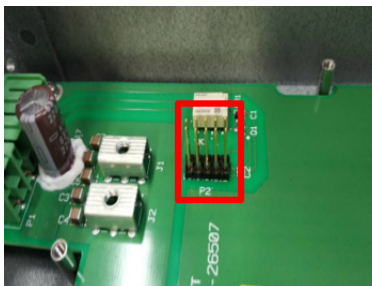

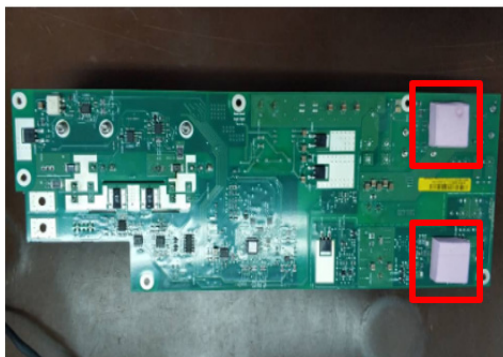

Ensure that the two thermal pad are present on each of the PCA mainboards before proceeding with the next step.



20 Remove two screws from the IO board using a T10 bit.



Step	Instructions	Visuals
21	Remove three screws from the IO board using a T10 bit. Remove the IO board from the chassis.	
22	Unsolder the binding post assembly from the IO board. Remove the four screws with a T-10 bit. Replace the existing binding post assembly with a new binding post assembly.	
23	Perform the steps above in reverse order to reassemble back the instrument.	

For E36234A models only

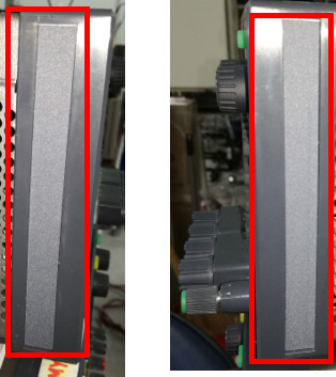
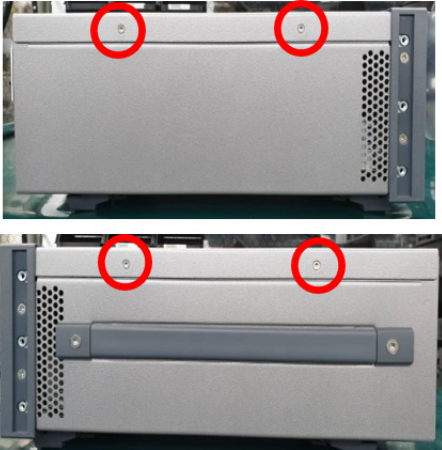
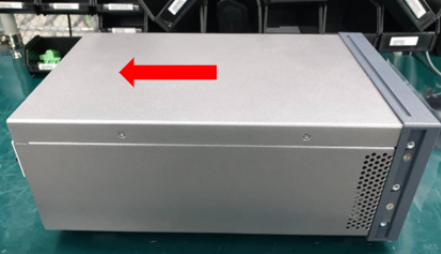
Step	Instructions	Visuals
1	Remove the side trims from the front panel.	
2	Remove four screws from the front panel using a T10 driver (two screws on each side).	
3	Remove the top panel. Slide the top panel towards the rear and lift it up.	

Step	Instructions	Visuals
------	--------------	---------

4 Remove the IO board thermal pad.

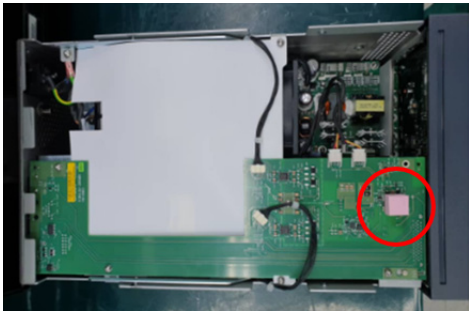

5 Remove four Pozi screws from the front panel using a PZ1 driver (two screws on each side).

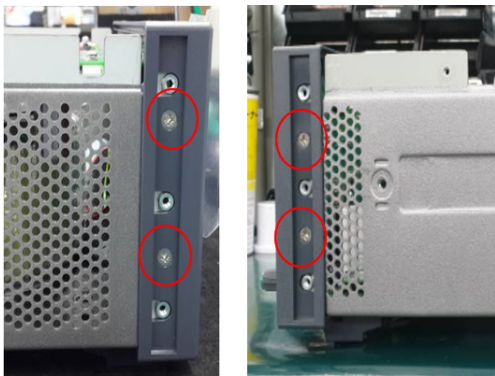

6 Detach the mainboard connectors from the IO board.

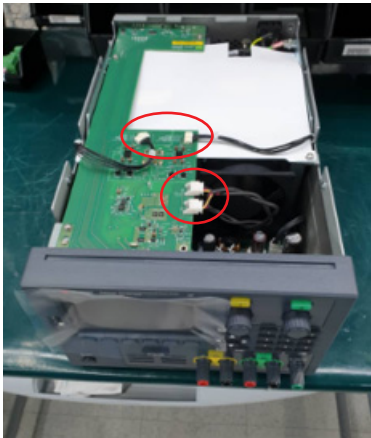

1 Service and Maintenance

Step	Instructions	Visuals
------	--------------	---------

7 Gently pull out the front frame from the chassis.



8 Detach the power PSU connector from the IO board.

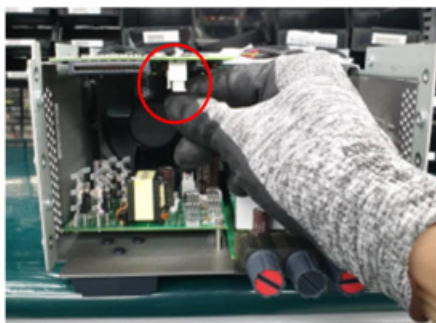

Step	Instructions	Visuals
------	--------------	---------

9 Remove four screws from the IO board using a T10 driver. Remove the IO board from the chassis.

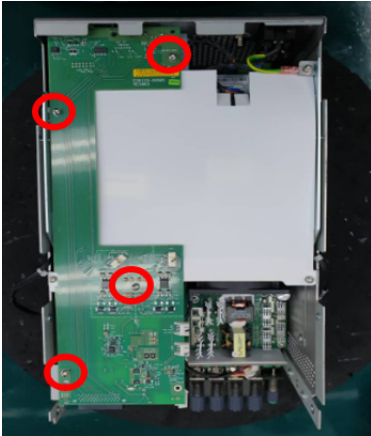

NOTE: Perform step 10 and step 12 only if you have installed the optional GPIB interface (see "Removing/Installing the optional GPIB interface" on page 20 for more details).

10 Remove one screw from the GPIB module plate using a T10 driver.

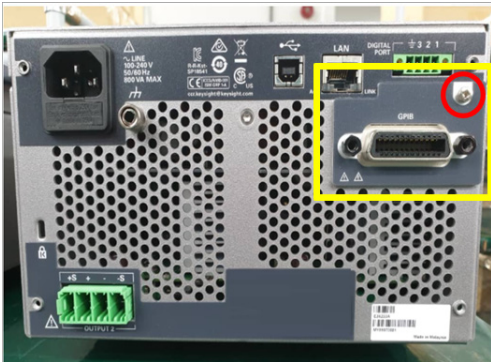

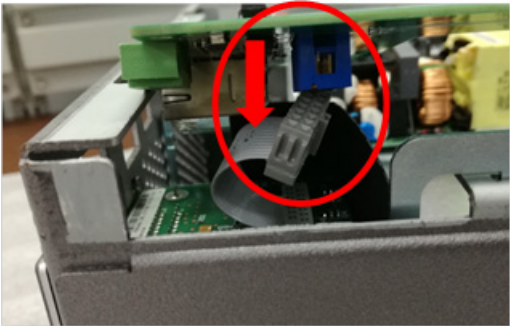
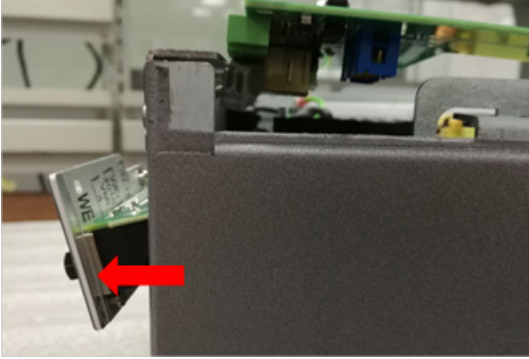

1 Service and Maintenance

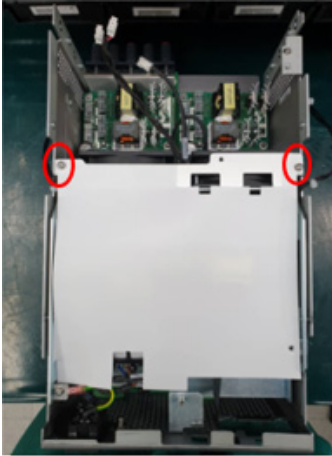
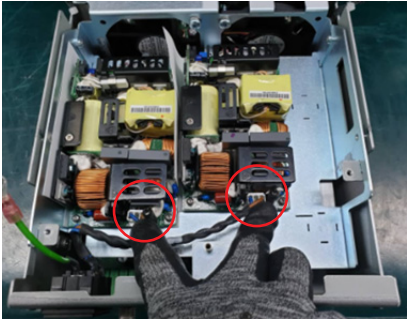
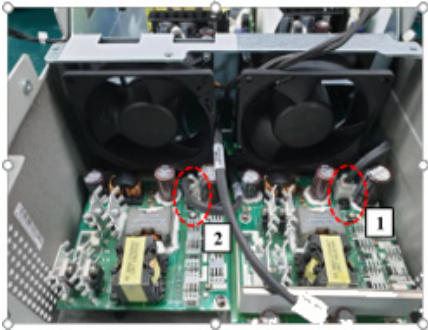
Step	Instructions	Visuals
11	Detach the GPIB module connector from the IO board.	 A close-up photograph of the internal components of a device. A GPIB module connector is being detached from the IO board. A red circle highlights the connector, and a red arrow points downwards, indicating the direction of removal.
12	Remove the GPIB module from the chassis.	 A close-up photograph of the GPIB module being removed from the chassis. A red arrow points to the left, indicating the direction of removal.

Step	Instructions	Visuals
13	Remove two screws from the insulator using a T10 bit. Remove the insulator.	
14	Detach the AC inlet connector from the PSU module.	
15	Detach the power PSU connectors from the mainboard.	

1 Service and Maintenance

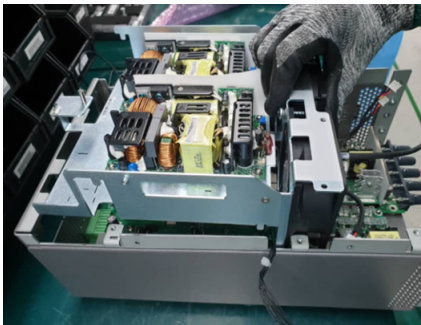
Step	Instructions	Visuals
16	Remove one screw from the rear chassis using a T10 bit.	 A photograph showing the rear panel of a device. A single screw on the right side of the perforated metal panel is circled in red. The panel has various ports and labels.
17	Remove two screws from the bracket using a T10 bit. Remove the bracket from the chassis.	  Two photographs. The top one shows a close-up of a metal bracket with two screws circled in red. The bottom one shows a hand using a T10 bit to remove one of these screws from the bracket, which is being lifted away from the internal components of the chassis.

Step	Instructions	Visuals
------	--------------	---------

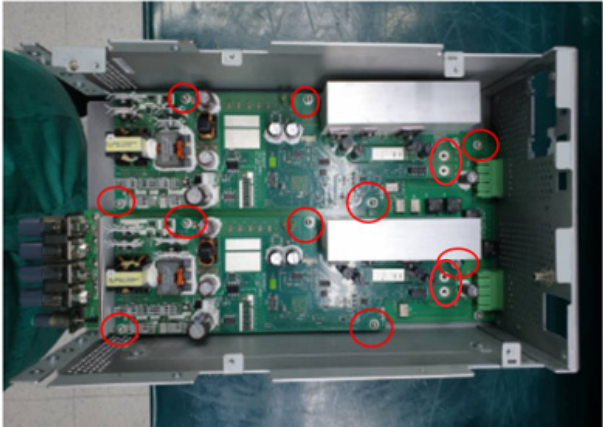

18 Remove 14 screws from the PCA mainboard using a T10 bit.

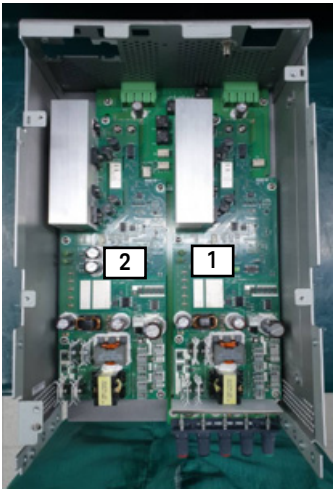

19 Lift and remove the the two PCA mainboards from the chassis.

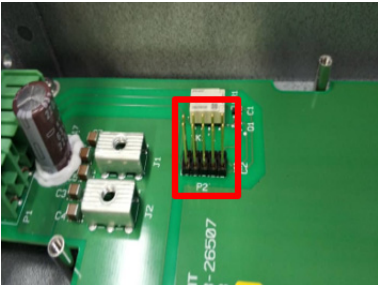
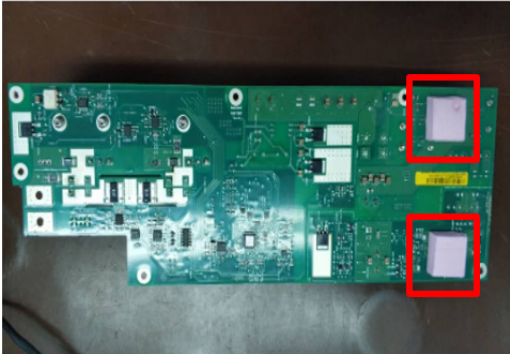

1 Service and Maintenance

Step	Instructions	Visuals
	<i>Take caution not to bend any of the connector pins on the IO board.</i>	
	<i>Ensure that the two thermal pad are present on each of the PCA mainboards before proceeding with the next step.</i>	
20	Remove two screws from the IO board using a T10 bit.	

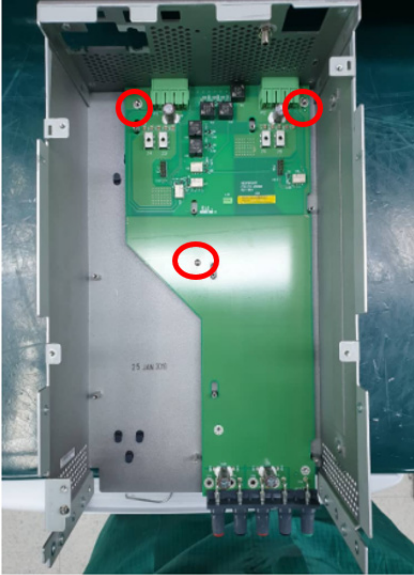
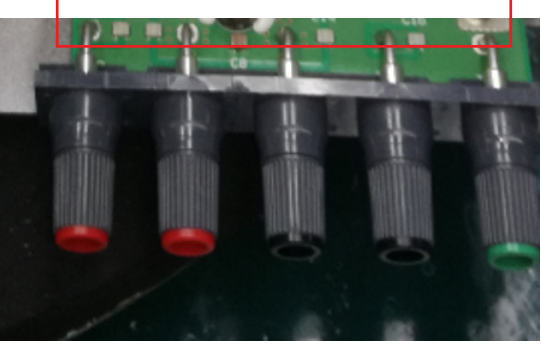
Step	Instructions	Visuals
21	Remove three screws from the IO board using a T10 bit. Remove the IO board from the chassis.	
22	Unsolder the binding post assembly from the IO board. Replace the existing binding post assembly with a new binding post assembly.	
23	Perform the steps above in reverse order to reassemble back the instrument.	

THIS PAGE HAS BEEN INTENTIONALLY LEFT BLANK.

2 Verification and Adjustments

Performance Verification	54
Test Record Forms	74
Calibration Adjustment Procedures	82

This chapter contains the performance verification procedures, which verifies that the E36200 Series is operating within its published specifications. This chapter also provides information on the adjustments performed after the instrument fails any of the performance verification tests.

Performance Verification

Performance verification ensures that the instrument performs within the specifications stated in its data sheet (<http://literature.cdn.keysight.com/litweb/pdf/5992-3747EN.pdf>.)

Recommended test equipment

The test equipments recommended for the performance verification and adjustment procedures are listed below. If the exact instrument is not available, use the accuracy requirements shown to select substitute calibration standards.

Type	Specification	Recommended model
Digital multimeter	Readout: 6 ½ digits Basic DC accuracy: 0.0035%	Keysight 34465A or equivalent
Current monitor	50 A (0.05 Ω), TC = 4 ppm/°C	Guildline 9230A-50
Electronic load	150 V, 20 A minimum, with transient capability and a slew rate of 833 kA/s or better	Keysight N3300A mainframe, with N330xA modules
Fixed load	Wirewound resistor 1000 W, 40 Ω E36232A and E36234A output: 18 Ω	DSR-1000W40RJ-F-V1
	Wirewound resistor 1000 W, 10 Ω E36231A and E36233A output: 4.5 Ω	DSR-1000W10RJ-F-V1
	Wirewound resistor 2000 W, 2.5 Ω E36232A and E36234A output: 2 Ω	DSR-2000W2R5J-F-V1
	Wirewound resistor 2000 W, 0.6 Ω E36231A and E36233A output: 0.5 Ω	DSR-2000WR6J-F-V1
Oscilloscope	Sensitivity: 1 mV Bandwidth limit: 20 MHz Probe: 1:1 with RF tip	Keysight Infiniium/6054A or equivalent
RMS voltmeter	True RMS Bandwidth: 10 MHz Sensitivity: 100 μV	Keysight 3458A or equivalent
Differential amplifier	Bandwidth: 20 MHz	LeCroy 1855A or equivalent

Type	Specification	Recommended model
Terminations	1 – 50 Ω BNC termination	N/A
	2 – 50 Ω , \geq 1/8 W resistor	
Variable voltage transformer or AC source	Adjustable to highest rated input voltage range Power: 500 VA	Keysight 6813B or equivalent
Calibration resistors for low range current	E36231/E36233A output: 300 Ω high power resistor, 100 W	ARCOL HS100 300R F
	E36232A/E36234A output: 1.2 k Ω power resistor, 75 W	ARCOL HS75 1K2 F

Test considerations

- Ensure that the calibration ambient temperature is stable and between 20 °C and 30 °C.
- Ensure ambient relative humidity is less than 80%.
- Allow a 1-hour warm-up period before verification or calibration.
- Keep cables as short as possible, consistent with the impedance requirements.
- Performance verification and calibration procedure must be performed through rear panel output.

CAUTION

The tests should be performed by qualified personnel. During performance verification tests, hazardous voltages may be present at the outputs of the power supply.

NOTE

Refer to the *E36200 Series Programming Guide* for more information on the SCPI commands used in this chapter.

NOTE

For E36233A and E36234A models, perform the verification test described below for Output 1 and then repeat the test again for Output 2.

Measurement techniques

Voltmeter

To ensure that the values read by the voltmeter during both the verification procedure and the calibration procedure are not affected by the instantaneous measurement of the AC peaks of the output current ripple, make several DC measurements and average them.

Current-monitoring resistor

The 4-terminal current shunt is used to eliminate output current measurement error caused by voltage drops in the load leads and connections. It has special current-monitoring terminals inside the load connection terminals. Connect the voltmeter directly to these current-monitoring terminals.

Electronic load

Many of the test procedures require the use of a variable load capable of dissipating the required power. If a variable resistor is used, switches should be used to connect, disconnect, or short the load resistor. For most tests, an electronic load can be used. The electronic load is considerably easier to use than load resistors, but it may not be fast enough to test transient recovery time and may be too noisy for the noise (PARD) tests.

Fixed load resistors may be used in place of a variable load, with minor changes to the test procedures. Also, if computer controlled test setups are used, the relatively slow (compared to computers and system voltmeters) settling times and slew rates of the power system may have to be taken into account. "Wait" statements can be used in the test program if the test system is faster than the power system.

Setup for most tests

This setup is used for most tests and it requires the DMM, electronic load, and power supply being verified. Some wire is also required for connection between instruments. A LAN or USB cable is needed for readback data. The DMM measures the power supply output, and the electronic load draws current from the power supply. The accuracy of the current monitoring resistor must be 0.01% or better, which should include any self-heating effects.

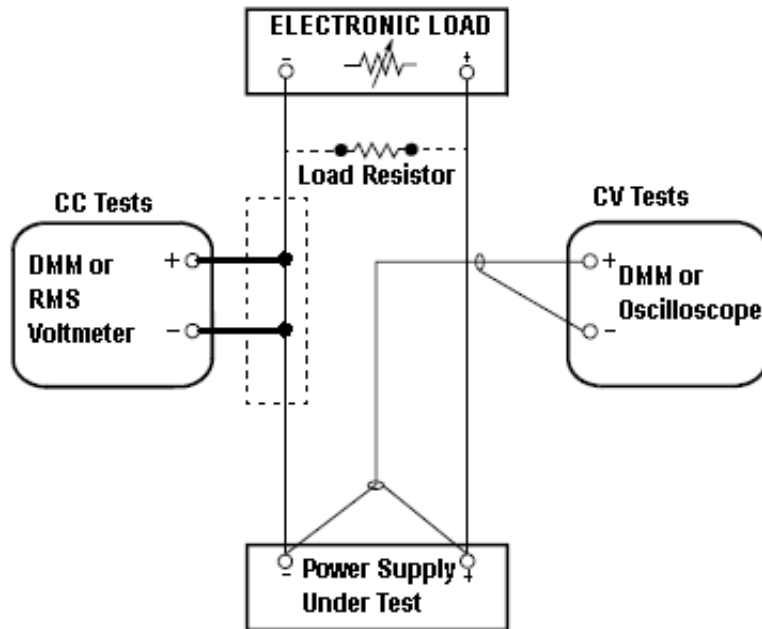

This setup is used for most tests and it requires the DMM, electronic load, and power supply being verified. Some wire is also required for connection between instruments. A LAN or USB cable is needed for readback data. The DMM measures the power supply output, and the electronic load draws current from the power supply. The accuracy of the current monitoring resistor must be 0.01% or better, which should include any self-heating effects.

Constant Voltage (CV) verification

Voltage programming and readback accuracy

These tests verify that the voltage programming and the LAN or USB readback functions are within specifications. Note that the readback values over the remote interface should be identical to those displayed on the front panel, but with maximum resolution.

- 1 Turn off the power supply using the AC line switch.
- 2 Connect a DMM between the (+) and (-) terminals of the output.
- 3 If you are using a PC to control the power supply, connect a LAN, GPIB, or USB cable from the power supply to the PC.
- 4 Turn on the power supply using the AC line switch.

Voltage programming accuracy

Step	Front panel	SCPI
5	Set the instrument settings as described in Table 2-1 .	VOLT 30, (@<channel>; CURR 20, (@<channel>) This is an example for the E36231A, 20 V, 20 A output.
6	Enable the output by pressing the On key for the selected output.	OUTP ON, (@<channel>)

The output status should be CV and the output current should be close to zero.

- 7 Record the voltage measured by the DMM in the “[Test Record Forms](#)” on page 74 and verify whether it is within the limits calculated.

Voltage readback accuracy

Step	Front panel	SCPI
8		MEAS:VOLT?, (@<channel>) This is an example for the E36231A, 30 V, 20 A output.

- 9 Record the voltage returned by the SCPI command query via the Keysight Connection Expert in the “[Test Record Forms](#)” on page 74 , and verify whether it is within the limits calculated.

Table 2-1 Voltage programming and readback accuracy instrument settings

Model	DUT settings		Programming accuracy		Readback accuracy	
	Voltage (V)	Current (A)	Lower limit	Upper limit	Lower limit	Upper limit
E36231A / E36233A	0	20	-0.004 V	0.004 V	-0.004 V	0.004 V
	30	20	29.987 V	30.013 V	-0.013 V	0.013 V
E36232A / E36234A	0	10	-0.008 V	0.008 V	-0.008 V	0.008 V
	60	10	59.974 V	60.026 V	-0.026 V	0.026 V

CV load and line regulation

These tests verify that the voltage variation due to load or line variation are within specifications.

CV load regulation

This test measures the change in output voltage resulting from a change in output current from full load to no load.

- 1 Turn off the power supply using the AC line switch.
- 2 Connect the power supply output with a DMM and an electronic load.
- 3 If you are using a PC to control the power supply, connect a LAN, GPIB, or USB cable from the power supply to the PC.
- 4 Turn on the power supply using the AC line switch.
- 5 Set the power supply settings as described in [Table 2-2](#).
- 6 Enable the output.

- 7 Operate the electronic load in constant current mode and set its current to the value described in [Table 2-2](#).

Check that the front panel **CV** annunciator of the power supply remains lit. If it turns to **CC** or **UNREG**, adjust the load so that the output current drops slightly until the **CV** annunciator lights up. Record the output voltage reading on the DMM as V_{load} .

- 8 Operate the electronic load in open mode (input off). Record the output voltage reading on the DMM immediately as V_{noload} .
- 9 Take the difference between the DMM readings in [step 7](#) and [step 8](#) that is the CV load regulation ($V_{load} - V_{noload}$). Record the calculated value in the “[Test Record Forms](#)” on page 74. The difference of the readings during the immediate change should be within the specification limits.

Table 2-2 CV load regulation instrument setting

Model	DUT settings		E-load settings		Load regulation	
	Voltage (V)	Current (A)	Mode	Current (A)	Lower limit	Upper limit
E36231A / E36233A	30	Max	Current	6.667	-5 mV	5 mV
	10	Max	Current	20	-3 mV	3 mV
E36232A / E36234A	60	Max	Current	3.333	-8 mV	8 mV
	20	Max	Current	10	-4 mV	4 mV

CV line regulation

This test measures the change in output voltage that results from a change in AC line voltage from the minimum to maximum value within the line voltage specifications.

- 1 Turn off the power supply using the AC line switch.
- 2 Connect the power supply output with a DMM and an electronic load.
- 3 Connect a variable AC Source or Variac to the AC input, and set to an appropriate line voltage for the power supply configuration.
- 4 If you are using a PC to control the power supply, connect a LAN, GPIB, or USB cable from the power supply to the PC.

- 5 Turn on the power supply using the AC line switch.
- 6 Set the power supply settings as described in [Table 2-3](#).
- 7 Enable the output.
- 8 Operate the electronic load in constant current mode and set its current to the value described in [Table 2-3](#).
Check that the front panel **CV** annunciator of the power supply remains lit. If it turns to **CC** or **UNREG**, adjust the load so that the output current drops slightly until the **CV** annunciator lights up.
- 9 Adjust the AC power source to the low line voltage limit (see [Table 2-3](#)). Record the output reading on the DMM as V_{lowline} .
- 10 Adjust the AC power source to the high line voltage limit (see [Table 2-3](#)). Record the output reading on the DMM as V_{highline} .
- 11 Take the difference between the DMM readings in [step 9](#) and [step 10](#) that is the CV line regulation ($V_{\text{lowline}} - V_{\text{highline}}$). Record the calculated value in the “[Test Record Forms](#)” on page 74. The difference of the readings during the immediate change should be within the limit calculated from the specification.

Table 2-3 CV line regulation instrument setting

Model	DUT settings		AC source settings		E-Load settings		Line regulation		
	Voltage (V)	Current (A)	Low	High	Mode	Current (A)	Lower limit	Upper limit	Line Voltage
E36231A / E36233A	30	Max	90 VAC	132 VAC	Current	6.667	-5 mV	5 mV	100 VAC - 120 VAC
	10	Max			Current	20	-3 mV	3 mV	
	30	Max	180 VAC	264 VAC	Current	6.667	-5 mV	5 mV	200 VAC - 240 VAC
	10	Max			Current	20	-3 mV	3 mV	
E36232A / E36234A	60	Max	90 VAC	132 VAC	Current	3.333	-5 mV	5 mV	100 VAC - 120 VAC
	20	Max			Current	10	-3 mV	3 mV	
	60	Max	180 VAC	264 VAC	Current	3.333	-5 mV	5 mV	200 VAC - 240 VAC
	20	Max			Current	10	-3 mV	3 mV	

Transient response verification

This test measures the time for the output voltage to recover to within the specified value following a 50% change in the load current.

- 1 Turn off the power supply using the AC line switch.
- 2 Connect an oscilloscope and electronic load between the (+) and (-) terminals of the output to be tested as shown below.

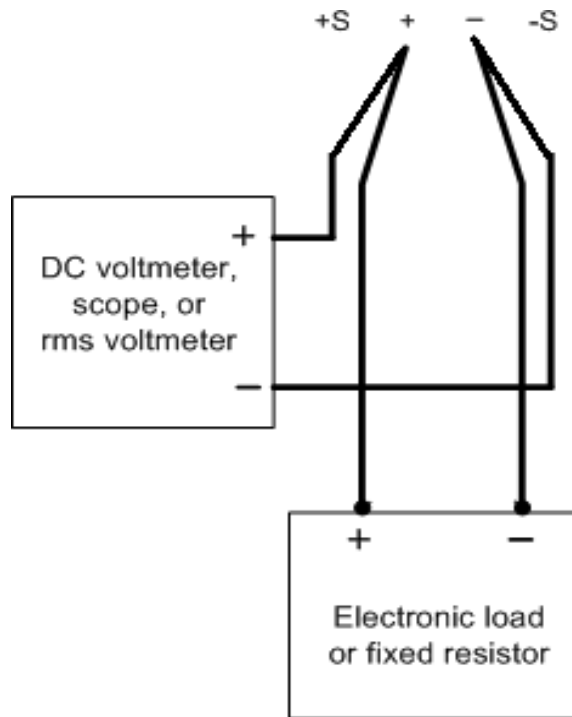

- 3 If you are using a PC to control the power supply, connect a LAN, GPIB, or USB cable from the power supply to the PC.
- 4 Turn on the power supply using the AC line switch.
- 5 Set the instrument settings as described in [Table 2-4](#).
- 6 Enable the output.

- 7 Operate the electronic load in constant current mode and set its current to the value described in [Table 2-4](#).

Set the transient level to $\frac{1}{2}$ the maximum current. Set the transient duty cycle to 50% and transient frequency to 1 kHz. Check that the front panel **CV** annunciator of the power supply remains lit. If it turns to **CC** or **UNREG**, adjust the maximum current load so that the output current drops slightly until the **CV** annunciator lights up.

- 8 Adjust the oscilloscope to display transients as shown below. Note that the pulse width ($t_2 - t_1$) of the transient at the voltage settling band, for example 15 mV for the E36234A Output 1 from the base line is no more than 50 μ s.



NOTE

- The oscilloscope cursors X1 and X2 represent t_1 and t_2 .
- The oscilloscope green trace and yellow trace represent output current and output voltage trace.

Record the measured value in the “[Test Record Forms](#)” on page 74. The transient response specification is met when the voltage recovers within 50 μ s.

Table 2-4 Transient response verification instrument setting

Model	DUT Setting		E-Load		Transient Response	
	Voltage (V)	Current (A)	Current (A)	T-Level	Lower limit	Upper limit
E36231A / E36233A	30	MAX	6.667	3.333	-	50 μ s
	10	MAX	20	10	-	50 μ s
E36232A / E36234A	60	MAX	3.333	1.67	-	50 μ s
	20	MAX	10	5	-	50 μ s

Output noise verification

Periodic and random output deviations superimpose a residual AC voltage on the DC output. This residual voltage is specified as the rms or peak-to-peak noise in and is specified in the product data sheet.

- 1 Turn off the power supply using the AC line switch.
- 2 Connect a fixed load, differential amplifier, and an oscilloscope (AC coupled) to the output as shown below.

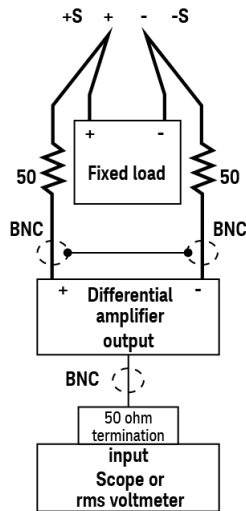

- 3 Turn on the power supply using the AC line switch.

- 4 Use an appropriate load resistor (see the fixed load value in the **Recommended test equipment** list) to keep the power system at the instrument setting specified in **Table 2-6**.
- 5 As shown in the figure, use two BNC cables to connect the differential amplifier to the (+) and (-) output terminals. Each cable should be terminated by a 50 Ω resistor. The shields of the two BNC cables should be connected together. Connect the differential amplifier output to the oscilloscope with a 50 Ω termination at the oscilloscope input.
- 6 Set the differential amplifier to multiply by ten, divide by one, and 1 M Ω input resistance. Set the differential amplifier's positive and negative inputs to AC coupling. Set the oscilloscope's time base to 5 ms/div, and the vertical scale to 10 mV/div. Turn the bandwidth limit on (usually 20 or 30 MHz), and set the sampling mode to peak detect.
- 7 Program the power supply to the settings indicated in the in the test record form for the appropriate model under **Table 2-6** and enable the output.

Let the oscilloscope run for a few seconds to generate enough measurement points. On the Keysight Infiniium oscilloscope, the maximum peak-to-peak voltage measurement is indicated at the bottom of the screen on the right side. Divide this value by 10 to get the CV peak-to-peak noise measurement. The result should not exceed the peak-to-peak upper limits for instrument's "CV ripple and noise, peak-to-peak" value. See the "**Test Record Forms**" on page 74 for details.
- 8 Disconnect the oscilloscope and connect an rms voltmeter in its place. Do not disconnect the 50 Ω termination. Divide the reading of the rms voltmeter by 10. The result should not exceed the rms limits in the test record form for the appropriate model under "CV ripple and noise, rms". See the "**Test Record Forms**" on page 74 for details.

Table 2-5 CV ripple and noise, peak-to-peak instrument settings

Model	DUT settings		Fixed load	RMS noise	
	Voltage (V)	Current (A)	Value (Ω)	Lower limit	Upper limit
E36231A / E36233A	30	MAX	4.5	-	4.5 mV
	10	MAX	0.5	-	4.5 mV
E36232A / E36234A	60	MAX	18	-	3.5 mV
	20	MAX	2	-	3.5 mV

Table 2-6 CV ripple and noise, rms instrument settings

Model	DUT settings		Fixed load	Peak-to-peak noise	
	Voltage (V)	Current (A)	Value (Ω)	Lower limit	Upper limit
E36231A / E36233A	30	MAX	4.5	-	0.35 mV
	10	MAX	0.5	-	0.35 mV
E36232A / E36234A	60	MAX	18	-	0.35 mV
	20	MAX	2	-	0.35 mV

Low range current verification

Low range current programming and readback accuracy

These tests verify that the current programming and the LAN, GPIB, or USB readback measurement functions are within specifications. Note that the readback values over the remote interface should be identical to those displayed on the front panel, but with maximum resolution.

- 1 Turn off the power supply using the AC line switch.
- 2 Connect a DMM between the (+) and (-) terminals of the output.
- 3 Connect appropriate resistor in series with the (+) terminals of the power supply and (+) terminals of the DMM as shown below.

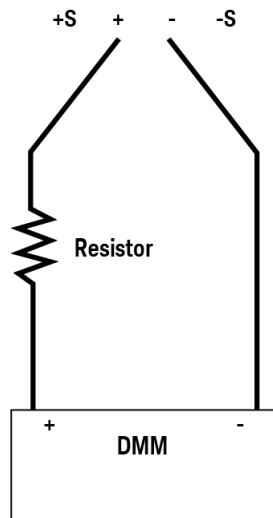

- 4 If you are using a PC to control the power supply, connect a LAN, GPIB, or USB cable from the power supply to the PC.
- 5 Turn on the power supply using the AC line switch.

Low range current readback accuracy

Step	Front panel	SCPI
6	Set the instrument settings as described in Table 2-7 .	VOLT 60, (@<channel>); CURR 0.1, (@<channel>) This is an example for the E36234A, 60 V, 50 mA output.
7	Enable the output by pressing the On key for the selected output.	OUTP ON, (@<channel>)
8	The output status should be CV and the output current should be close to targeted current (50 mA for the E36234A, 60 V, 50 mA output).	
9	Record the current measured by the DMM and current returned by the SCPI MEAS:CURR?, (@channel) command query via the Keysight Connection Expert in the “ Test Record Forms ” on page 74, and verify whether it is within the limits calculated.	MEAS:CURR?, (@<channel>) This is an example for the E36234A, 60 V, 50 mA output.

Table 2-7 Low range current programming and readback accuracy instrument settings

Model	DUT settings		Readback accuracy	
	Voltage (V)	Current (A)	Lower limit	Upper limit
E36231A / E36233A	30	0.2 ^[a]	-410 μ A	410 μ A
E36232A / E36234A	60	0.1 ^[a]	-205 μ A	205 μ A

[a] The current set need to double up when perform Low Range Current Readback Verification to ensure output status turn to CV. For example, maximum Low Range Current of E36231A is 0.1 A, the Current need to set as 0.2 A.

Constant Current (CC) verification

Current programming and readback accuracy

These tests verify that the current programming and the LAN, GPIB, or USB readback measurement functions are within specifications. Note that the readback values over the remote interface should be identical to those displayed on the front panel, but with maximum resolution.

- 1 Turn off the power supply using the AC line switch.
- 2 Connect the current shunt directly across the output terminals. Connect the DMM directly across the current shunt.
- 3 If you are using a PC to control the power supply, connect a LAN, GPIB or USB cable from the power supply to the PC.
- 4 Turn on the power supply using the AC line switch.

Current programming accuracy

Step	Front panel	SCPI
5	Set the instrument settings as described in Table 2-8 .	<code>VOLT MAX, (@<channel>); CURR 10, (@<channel>)</code> This is an example for the E36234A, MAX V, 5 A output.
6	Enable the output by pressing the On key for the selected output.	<code>OUTP ON, (@<channel>)</code>

- 7 The output status should be **CC** and the output voltage should be close to zero.
- 8 Divide the voltage drop (DMM reading) across the current shunt by the shunt resistance to convert to amps.
- 9 Record the current measured by the DMM and verify whether it is within the limits calculated.

Current readback accuracy

Step	Front panel	SCPI
10		MEAS:CURR?, (@<channel>) This is an example for the E36234A, MAX V, 5 A output.

- 11 Record the current returned by the SCPI command query via the Keysight Connection Expert in the “Test Record Forms” on page 74, and verify whether it is within the limits calculated.

Table 2-8 Current programming and readback accuracy instrument settings

Model	DUT settings		Programming accuracy		Readback accuracy	
	Voltage (V)	Current (A)	Lower limit	Upper limit	Lower limit	Upper limit
E36231A / E36233A	MAX	0	-0.006 A	0.006 A	-0.006 A	0.006 A
	MAX	20	19.974 A	20.006 A	-0.026 A	0.026 A
E36232A / E36234A	MAX	0	-0.003 A	0.003 A	-0.003 A	0.003 A
	MAX	10	9.987 A	10.013 A	-0.013 A	0.013 A

CC load regulation

This test measures the change in output current resulting from a change in output voltage from full scale to short circuit.

- 1 Turn off the power supply using the AC line switch.
- 2 Connect the power supply output with a DMM, an electronic load, and a current shunt as shown below.

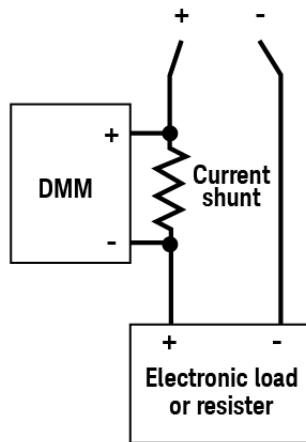

- 3 Program the output voltage and output current as described in the test record form under CC load regulation.
- 4 Turn on the power supply using the AC line switch.
- 5 Enable the output by sending the command **OUTP ON** or by pressing the output **[On]** key.
- 6 Operate the electronic load in constant voltage mode and set its voltage to the power supply output value as described in [Table 2-9](#).

Check that the front panel **CC** annunciator of the power supply remains lit. If it turns to **CV** or **UNREG**, adjust the load so that the output current drops slightly until the **CC** annunciator lights up. Record the current reading (I_{load}), by dividing the voltage reading on the DMM by the resistance of the current monitoring resistor.

- 7 Operate the electronic load in short (input short) mode. Record the current reading, (I_{short}), by dividing the voltage reading on the DMM by the resistance of the current monitoring resistor.
- 8 Take the difference between the current readings in [step 6](#) and [step 7](#) is the load regulation current ($I_{\text{load}} - I_{\text{short}}$). Record the calculated value in the “[Test Record Forms](#)” on page 74. The difference of the readings during the immediate change should be within the specification limits.

Table 2-9 CC load regulation instrument settings

Model	DUT settings		E-load settings		Load regulation	
	Voltage (V)	Current (A)	Mode	Voltage (V)	Lower limit	Upper limit
E36231A / E36233A	MAX	6.667	Voltage	30	-0.9167 mA	0.9167 mA
	MAX	20	Voltage	10	-2.250 mA	2.250 mA
E36232A / E36234A	MAX	3.333	Voltage	60	-0.5833 mA	0.5833 mA
	MAX	10	Voltage	20	-1.250 mA	1.250 mA

CC line regulation

- 1 Turn off the power supply using the AC line switch.
- 2 Connect the power supply output with a DMM, an electronic load, and a current shunt. See “[Recommended test equipment](#)” on page 54 for details.
- 3 Connect the AC power cord of the power supply to the AC power source.
- 4 Turn on the power supply using the AC line switch.
- 5 Program the output voltage and output current as described in the test record form under CC line regulation.
- 6 Operate the electronic load in constant voltage mode and set its voltage to the power supply output value as described in [Table 2-10](#).

Check that the front panel **CC** annunciator of the power supply remains lit. If it turns to **CV** or **UNREG**, adjust the load so that the output current drops slightly until the **CC** annunciator lights up.

- 7 Adjust the AC power source to low line voltage limit (see [Table 2-10](#)). Record the output current reading (I_{lowline}) by dividing the voltage reading on the DMM by the resistance of the current monitoring resistor.
- 8 Adjust the AC power source to high line voltage (see [Table 2-10](#)). Record the current reading (I_{highline}) again immediately by dividing the voltage reading on the DMM by the resistance of the current monitoring resistor.
- 9 Take the difference between the DMM readings in [step 7](#) and [step 8](#) is the CC line regulation ($I_{\text{lowline}} - I_{\text{highline}}$). Record the calculated value in the “[Test Record Forms](#)” on page 74. The difference of the readings during the immediate change should be within the specification limits.

Table 2-10 CC line regulation instrument settings

Model	DUT settings		AC source settings		E-load settings		Line regulation		
	Voltage (V)	Current (A)	Low	High	Mode	Voltage (V)	Lower limit	Upper limit	Line voltage
E36231A/ E36233A	MAX	6.667	90 VAC	132 VAC	Voltage	30	-0.9167 mA	0.9167 mA	100 VAC - 120 VAC
	MAX	20			Voltage	10	-2.250 mA	2.250 mA	
	MAX	6.667	180 VAC	264 VAC	Voltage	30	-0.9167 mA	0.9167 mA	200 VAC - 240 VAC
	MAX	20			Voltage	10	-2.250 mA	2.250 mA	
E36232A/ E36234A	MAX	3.333	90 VAC	132 VAC	Voltage	60	-0.5833 mA	0.5833 mA	100 VAC - 120 VAC
	MAX	10			Voltage	20	-1.250 mA	1.250 mA	
	MAX	3.333	180 VAC	264 VAC	Voltage	60	-0.5833 mA	0.5833 mA	200 VAC - 240 VAC
	MAX	10			Voltage	20	-1.250 mA	1.250 mA	

Test Record Forms

- “Test record form - Keysight E36231A” on page 74
- “Test record form - Keysight E36232A” on page 76
- “Test record form - Keysight E36233A” on page 78
- “Test record form - Keysight E36234A” on page 80

Table 2-11 Test record form - Keysight E36231A

E36231A	Report number _____	Date _____		
Description	DUT setting	Lower limit	Result	Upper limit
Constant voltage tests				
Voltage programming				
Zero voltage output (V_0)	0 V, 20 A	-0.004 V	_____	0.004 V
Maximum voltage output (V_{max})	30 V 20 A	29.987 V	_____	30.013 V
Voltage readback				
Zero voltage measured over interface	0 V, 20 A	$V_0 - 0.004$ V	_____	$V_0 + 0.004$ V
Maximum voltage measured over interface	30 V 20 A	$V_{max} - 0.013$ V	_____	$V_{max} + 0.013$ V
CV load regulation ($V_{load} - V_{noload}$)				
	30 V, Max A	-5 mV	_____	5 mV
	10 V, Max A	-3 mV	_____	3 mV
CV line regulation ($V_{lowline} - V_{highline}$)				
	30 V, Max A	-5 mV	_____	5 mV
	10 V, Max A	-3 mV	_____	3 mV
CV ripple and noise				
peak-to-peak	30 V, Max A	-	_____	4.5 mV
	10 V, Max A	-	_____	4.5 mV
rms	30 V, Max A	-	_____	0.35 mV
	10 V, Max A	-	_____	0.35 mV
Transient response				
	30 V, Max A	-	_____	50 μ s
	10 V, Max A	-	_____	50 μ s

Table 2-11 Test record form - Keysight E36231A (continued)

E36231A	Report number _____	Date _____		
Description	DUT setting	Lower limit	Result	Upper limit
Constant current tests				
Current programming				
Zero current output (I_0)	Max V, 0 A	-0.0060 A	_____	0.0060 A
Maximum current output (I_{max})	Max V, 20 A	19.974 A	_____	20.006 A
Current readback				
Zero current measured over interface	Max V, 0 A	$I_0 - 0.0060$ A	_____	$I_0 + 0.0060$ A
Maximum current measured over interface	Max V, 20 A	$I_{max} - 0.026$ A	_____	$I_{max} + 0.026$ A
CC load regulation ($I_{load} - I_{short}$)				
	Max V, 6.667 A	-0.9167 mA	_____	0.9167 mA
	Max V, 20 A	-2.250 mA	_____	2.250 mA
CC line regulation ($I_{lowline} - I_{highline}$)				
	Max V, 6.667 A	-0.9167 mA	_____	0.9167 mA
	Max V, 20 A	-2.250 mA	_____	2.250 mA
Low range current measurement				
Minimum low range current measured over interface ^[a]	30 V, 0.2 A	$I_{low\ max} - 410$ μ A	_____	$I_{low\ max} + 410$ μ A

[a] The current set need to double up when perform Low Range Current Readback Verification to ensure output status turn to CV. Maximum Low Range Current of E36231A is 0.1 A, the Current need to set as 0.2 A.

Table 2-12 Test record form - Keysight E36232A

E36232A	Report number _____	Date _____		
Description	DUT setting	Lower limit	Result	Upper limit
Constant voltage tests				
Voltage programming				
Zero voltage output (V_0)	0 V, 10 A	-0.008 V	_____	0.008 V
Maximum voltage output (V_{max})	60 V 10 A	59.974 V	_____	60.026 V
Voltage readback				
Zero voltage measured over interface	0 V, 10 A	$V_0 - 0.008$ V	_____	$V_0 + 0.008$ V
Maximum voltage measured over interface	60 V 10 A	$V_{max} - 0.026$ V	_____	$V_{max} + 0.026$ V
CV load regulation ($V_{load} - V_{noload}$)				
	60 V, Max A	-8 mV	_____	8 mV
	20 V, Max A	-4 mV	_____	4 mV
CV line regulation ($V_{lowline} - V_{highline}$)				
	60 V, Max A	-5 mV	_____	5 mV
	20 V, Max A	-3 mV	_____	3 mV
CV ripple and noise				
peak-to-peak	60 V, Max A	-	_____	3.5 mV
	20 V, Max A	-	_____	3.5 mV
rms	60 V, Max A	-	_____	0.35 mV
	20 V, Max A	-	_____	0.35 mV
Transient response				
	60 V, Max A	-	_____	50 μ s
	20 V, Max A	-	_____	50 μ s

Table 2-12 Test record form - Keysight E36232A (continued)

E36232A	Report number _____	Date _____		
Description	DUT setting	Lower limit	Result	Upper limit
Constant current tests				
Current programming				
Zero current output (I_0)	Max V, 0 A	-0.003 A	_____	0.003 A
Maximum current output (I_{max})	Max V, 10 A	9.987 A	_____	10.013 A
Current readback				
Zero current measured over interface	Max V, 0 A	$I_0 - 0.003$ A	_____	$I_0 + 0.003$ A
Maximum current measured over interface	Max V, 10 A	$I_{max} - 0.013$ A	_____	$I_{max} + 0.013$ A
CC load regulation ($I_{load} - I_{short}$)				
	Max V, 3.333 A	-0.9167 mA	_____	0.9167 mA
	Max V, 10 A	-2.250 mA	_____	2.250 mA
CC line regulation ($I_{lowline} - I_{highline}$)				
	Max V, 3.333 A	-0.5833 mA	_____	0.5833 mA
	Max V, 10 A	-1.250 mA	_____	1.250 mA
Low range current measurement				
Maximum low range current measured over interface ^[a]	60 V, 0.1 A	$I_{low\ max} - 205$ μ A	_____	$I_{low\ max} + 205$ μ A

[a] The current set need to double up when perform Low Range Current Readback Verification to ensure output status turn to CV. Maximum Low Range Current of E36232A is 0.05 A, the Current need to set as 0.1 A.

Table 2-13 Test record form - Keysight E36233A

E36233A		Report number _____	Date _____			
Description	DUT setting	Lower limit	Result		Upper limit	
			Output 1	Output 2		
Constant voltage tests						
Voltage programming						
Zero voltage output (V_0)	0 V, 20 A	-0.004 V	_____	_____	0.004 V	
Maximum voltage output (V_{max})	30 V 20 A	29.987 V	_____	_____	30.013 V	
Voltage readback						
Zero voltage measured over interface	0 V, 20 A	$V_0 - 0.004$ V	_____	_____	$V_0 + 0.004$ V	
Maximum voltage measured over interface	30 V 20 A	$V_{max} - 0.013$ V	_____	_____	$V_{max} + 0.013$ V	
CV load regulation ($V_{load} - V_{noload}$)	30 V, Max A	-5 mV	_____	_____	5 mV	
	10 V, Max A	-3 mV	_____	_____	3 mV	
CV line regulation ($V_{lowline} - V_{highline}$)	30 V, Max A	-5 mV	_____	_____	5 mV	
	10 V, Max A	-3 mV	_____	_____	3 mV	
CV ripple and noise						
peak-to-peak	30 V, Max A	-	_____	_____	4.5 mV	
	10 V, Max A	-	_____	_____	4.5 mV	
rms	30 V, Max A	-	_____	_____	0.35 mV	
	10 V, Max A	-	_____	_____	0.35 mV	
Transient response	30 V, Max A	-	_____	_____	50 μ s	
	10 V, Max A	-	_____	_____	50 μ s	

Table 2-13 Test record form - Keysight E36233A (continued)

E36233A		Report number _____	Date _____			
Description	DUT setting	Lower limit	Result		Upper limit	
			Output 1	Output 2		
Constant current tests						
Current programming						
Zero current output (I_0)	Max V, 0 A	-0.0060 A	_____	_____	0.0060 A	
Maximum current output (I_{max})	Max V, 20 A	19.974 A	_____	_____	20.006 A	
Current readback						
Zero current measured over interface	Max V, 0 A	$I_0 - 0.0060$ A	_____	_____	$I_0 + 0.0060$ A	
Maximum current measured over interface	Max V, 20 A	$I_{max} - 0.026$ A	_____	_____	$I_{max} + 0.026$ A	
CC load regulation ($I_{load} - I_{short}$)						
	Max V, 6.667 A	-0.9167 mA	_____	_____	0.9167 mA	
	Max V, 20 A	-2.250 mA	_____	_____	2.250 mA	
CC line regulation ($I_{lowline} - I_{highline}$)						
	Max V, 6.667 A	-0.9167 mA	_____	_____	0.9167 mA	
	Max V, 20 A	-2.250 mA	_____	_____	2.250 mA	
Low range current measurement						
Minimum low range current measured over interface ^[a]	30 V, 0.2 A	$I_{low\ max} - 410$ μ A	_____	_____	$I_{low\ max} + 410$ μ A	

[a] The current set need to double up when perform Low Range Current Readback Verification to ensure output status turn to CV. Maximum Low Range Current of E36233A is 0.1 A, the Current need to set as 0.2 A.

Table 2-14 Test record form - Keysight E36234A

E36234A		Report number _____	Date _____			
Description	DUT setting	Lower limit	Result		Upper limit	
			Output 1	Output 2		
Constant voltage tests						
Voltage programming						
Zero voltage output (V_0)	0 V, 10 A	-0.008 V	_____	_____	0.008 V	
Maximum voltage output (V_{max})	60 V 10 A	59.974 V	_____	_____	60.026 V	
Voltage readback						
Zero voltage measured over interface	0 V, 10 A	$V_0 - 0.008 V$	_____	_____	$V_0 + 0.008 V$	
Maximum voltage measured over interface	60 V 10 A	$V_{max} - 0.026 V$	_____	_____	$V_{max} + 0.026 V$	
CV load regulation ($V_{load} - V_{noload}$)	60 V, Max A	-8 mV	_____	_____	8 mV	
	20 V, Max A	-4 mV	_____	_____	4 mV	
CV line regulation ($V_{lowline} - V_{highline}$)	60 V, Max A	-5 mV	_____	_____	5 mV	
	20 V, Max A	-3 mV	_____	_____	3 mV	
CV ripple and noise						
peak-to-peak	60 V, Max A	-	_____	_____	3.5 mV	
	20 V, Max A	-	_____	_____	3.5 mV	
rms	60 V, Max A	-	_____	_____	0.35 mV	
	20 V, Max A	-	_____	_____	0.35 mV	
Transient response	60 V, Max A	-	_____	_____	50 μ s	
	20 V, Max A	-	_____	_____	50 μ s	

Table 2-14 Test record form - Keysight E36234A (continued)

E36234A		Report number _____	Date _____			
Description	DUT setting	Lower limit	Result		Upper limit	
			Output 1	Output 2		
Constant current tests						
Current programming						
Zero current output (I_0)	Max V, 0 A	-0.003 A	_____	_____	0.003 A	
Maximum current output (I_{max})	Max V, 10 A	9.987 A	_____	_____	10.013 A	
Current readback						
Zero current measured over interface	Max V, 0 A	$I_0 - 0.003$ A	_____	_____	$I_0 + 0.003$ A	
Maximum current measured over interface	Max V, 10 A	$I_{max} - 0.013$ A	_____	_____	$I_{max} + 0.013$ A	
CC load regulation ($I_{load} - I_{short}$)						
	Max V, 3.333 A	-0.9167 mA	_____	_____	0.9167 mA	
	Max V, 10 A	-2.250 mA	_____	_____	2.250 mA	
CC line regulation ($I_{lowline} - I_{highline}$)						
	Max V, 3.333 A	-0.5833 mA	_____	_____	0.5833 mA	
	Max V, 10 A	-1.250 mA	_____	_____	1.250 mA	
Low range current measurement						
Maximum low range current measured over interface ^[a]	60 V, 0.1 A	$I_{low\ max} - 205\ \mu A$	_____	_____	$I_{low\ max} + 205\ \mu A$	

[a] The current set need to double up when perform Low Range Current Readback Verification to ensure output status turn to CV. Maximum Low Range Current of E36234A is 0.05 A, the Current need to set as 0.1 A.

Calibration Adjustment Procedures

This chapter includes calibration adjustment procedures for the E36200 Series autoranging DC power supplies. Instructions are applicable for performing the procedures from either the front panel or a controller over the LAN, USB, or GPIB.

Perform the verification tests (see “[Performance Verification](#)” on page 54) before calibrating your instrument. If the instrument passes the verification tests, the unit is operating within its calibration limits and does not need to be re-calibrated.

Closed-case electronic calibration

The instrument uses closed-case electronic calibration; no internal mechanical adjustments are required. The instrument calculates the correction factors based on reference signals that you apply and stores the correction factors in the instrument’s non-volatile memory. This data is not changed by cycling power, ***RST**, or **SYSTem:PRESet**.

Calibration interval

The recommended calibration interval for the E36200 Series autoranging DC power supplies is one year.

Calibration adjustment process

The following general procedure is recommended to complete a full calibration adjustment.

- 1 Adhere to the test considerations. See “[Test considerations](#)” on page 55 for details.
- 2 Perform the performance verification tests to characterize the instrument. See “[Performance Verification](#)” on page 54 for details.
- 3 Unsecure the instrument for calibration. See “[Calibration security](#)” on page 83 for details.
- 4 Perform the calibration procedures. See “[Calibration procedure](#)” on page 86 for details.
- 5 Secure the instrument against the calibration. See “[Calibration security](#)” on page 83 for details.

- 6 Take note of the security code and calibration count in the instrument's maintenance records.
- 7 Perform the performance verification tests again to verify the calibration.

Calibration security

The instrument has a calibration passcode to prevent accidental or unauthorized calibration. When you receive your power supply, it is secured by a default passcode. The default passcode is 0. The security code cannot be changed by a power cycle or *RST.

You can enter a passcode of up to 9 digits.

You can change the passcode from both front panel and remote interface.

From the front panel:

- 1 Press **Utilities** > **Test / Setup** > **Calibration** > **Change Passcode**.
- 2 Enter your desired passcode and press **Done**.

From the remote interface:

To change a new passcode to "12345":

CALibration:SECurity:CODE 12345

NOTE

To change a forgotten passcode to a new passcode, you can turn on the instrument after shorting CAL_SECURE jumper J10 on the front panel board as shown below and send `CAL:SEC:CODE <code>` to change the passcode.

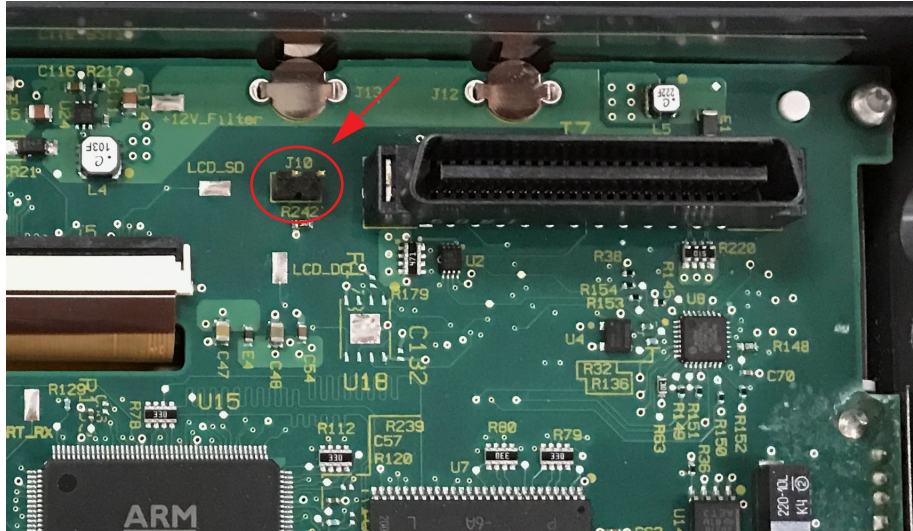

Calibration count

The instrument counts the number of times it has saved calibration data. Your instrument was calibrated at the factory; when you receive your instrument, read and record the initial count. You can only read the calibration count by sending the `CALibration:COUNT?` query, and the calibration count is not change by a power cycle or `*RST`.

If Auto Save is enabled, the count increments when you exit the calibration state. To avoid double counting, do not manually save the count with Auto Save enabled.

Calibration message

You can use the **CALibration:STRing** command to store a message of up to 40 characters in calibration memory. For example, you could store the last calibration date, the calibration due date, or contact information for the person responsible for calibration. The calibration message is not affected by a power cycle or ***RST**.

You can only store the calibration message when the instrument is unsecured, but you can execute the **CALibration:STRing?** query regardless of whether the instrument is secured. A new calibration message overwrites the previous message, and messages over 40 characters are truncated.

Saving calibration data

You must always save new calibration data before cycling instrument power or leaving the calibration state with the Auto Save feature off. To save calibration data, send **CALibration:SAVE** or save the calibration data from the front panel.

Calibration auto save

The instrument includes a calibration Auto Save feature. This feature automatically saves the calibration data to non-volatile memory and increments the calibration count when you exit the calibration state.

To enable or disable the calibration auto save feature, send **CALibration:ASAVE ON** or **CALibration:ASAVE OFF**. To query the calibration auto save state, send **CALibration:ASAV?**.

Calibration procedure

Enter the calibration state

To begin the calibration procedure, you must enter the calibration state.

Step	Front panel	SCPI
1	Press Utilities > Test / Setup > Calibration .	
	Enter the default passcode (default passcode is 0). Press Login to enter the calibration page.	<code>CAL:SEC:STAT 0, <code></code>
2	To change a forgotten passcode to a new passcode, you can turn on the instrument after shorting the CAL SECURE jumper J10 on the front panel board and sending the SCPI command shown on the right to change the passcode.	<code>CAL:SEC:CODE <new code></code>

Calibrate voltage

Allow the unit to sit with its output turned ON for one minute, then connect the DMM voltage input to the power supply.

Step	Front panel	SCPI
1	Press Perform Calibration . For E36233A and E36234A models, select the channel for calibration. Press Cal Volt .	<code>CAL:VOLT:LEV MIN, (@<channel>)</code>
2	Measure the output voltage (low point) with the DMM.	
3	Enter the measured value, and press Next .	<code>CAL:VOLT <reading>, (@<channel>)</code> <code>CAL:VOLT:LEV MAX, (@<channel>)</code>
4	Measure the output voltage (high point) with the DMM.	
5	Enter the measured value, and press Next .	<code>CAL:VOLT <reading>, (@<channel>)</code>
6	Read DONE or FAIL on the display.	<i>(wait 30 seconds)</i> <code>SYST:ERR?</code>
7	Press Cal Save .	<code>CAL:SAVE</code>

Calibrate current

Allow the unit to sit with its output turned ON for one minute, then connect a current monitoring resistor across the output terminals to be calibrated and then connect a DMM across the terminals of the monitoring resistor.

Step	Front panel	SCPI
1	Press Perform Calibration . For E36233A and E36234A models, select the channel for calibration. Press Cal Curr .	<code>CAL:CURR:LEV MIN, (@<channel>)</code>
2	Measure the output current (low point) with the DMM.	
3	Enter the measured value, and press Next .	<code>CAL:CURR <reading>, (@<channel>)</code> <code>CAL:CURR:LEV MAX, (@<channel>)</code>
4	Measure the output current (high point) with the DMM.	
5	Enter the measured value, and press Next .	<code>CAL:CURR <reading>, (@<channel>)</code>
6	Read DONE or FAIL on the display.	<i>(wait 30 seconds)</i> <code>SYST:ERR?</code>
7	Press Cal Save .	<code>CAL:SAVE</code>

Calibrate low range current

Allow the unit to sit with its output turned ON for one minute before continuing.

Step	Front panel	SCPI
1	Press Perform Calibration . For E36233A and E36234A models, select the channel for calibration. Press Cal Low Curr .	<code>CAL:CURR:LEV:LOW MIN, (@<channel>)</code>
2	Wait approximately 50 seconds. Connect the calibration resistor with the correct value as stated in the instructions shown on the display. Wait until a stable reading is obtained before you measure the output low range current (low point) with the DMM.	
3	Enter the measured value, and press Next .	<code>CAL:CURR:LOW <reading>, (@<channel>)</code> <code>CAL:CURR:LEV:LOW MAX, (@<channel>)</code>
4	Wait until a stable reading is obtained before you measure the output current (high point) with the DMM.	

2 Verification and Adjustments

Step	Front panel	SCPI
5	Enter the measured value, and press Next .	<code>CAL:CURR <reading>, (@<channel>)</code>
6	Read DONE or FAIL on the display.	<i>(wait 30 seconds)</i> <code>SYST:ERR?</code>
7	Press Cal Save .	<code>CAL:SAVE</code>

Save the calibration data

To save calibration data, go to the **CAL Save** menu to save the calibration data or enable the **Auto Save** feature. With Auto Save, the calibration data will be saved when you exit the calibration menu.

After completing the Voltage, Current, and Low Range Current calibrations, save the calibration data before exiting the calibration state, or simply exit the calibration state if Auto Save is turned **On**.

- To save the CAL data: `CAL:SAVE`
- To enable the CAL Auto Save: `CAL:ASAVE ON`
- To exit the CAL State: `CAL:STAT 1 <code>`



This information is subject to change without notice. Always refer to the Keysight website for the latest revision.

© Keysight Technologies 2019, 2021
Edition 2, May 21, 2021

Printed in Malaysia



E36200-90009

www.keysight.com